

# Student Handbook

2015-2016



Cumberland Campus  
Bedford County Campus  
Somerset County Campus

# **STUDENT SERVICES QUICK REFERENCE GUIDE**

*This is a partial listing of most frequently requested services.*

Academic Advising	
Advising Center (Cumberland Campus) .....	College Center, CC-141 301-784-5654
General .....	Your academic advisor
Transfer to Senior College or University (Cumberland Campus) .....	Student Success Center Humanities, H-58 301-784-5551
Admission to Allied Health Programs .....	Admissions Office College Center, CC-126 301-784-5204
Career Services (Cumberland Campus) .....	Student Success Center Humanities Building, H-58 301-784-5551
Center for Diversity & Student Engagement .....	College Center, CC-150 301-784-5205
Counseling Program .....	Office of Student & Legal Affairs College Center, CC-152 301-784-5206
Day Care for Children .....	Campus Kids Child Care Center Old Willowbrook Road 301-784-5236
Disability Services .....	Humanities Building, H-51 301-784-5112
Financial Aid .....	Student Financial Aid Office College Center, CC-138 301-784-5213
Graduation Requirements .....	Registration Office College Center, CC-145 301-784-5203
Non-Traditional Students .....	Humanities Building, H-51 301-784-5234
Pennsylvania Campuses Information.....	Directory, Section Eleven
Photo IDs .....	Office of Student Life College Center, CC-160 301-784-5205
Scholarships .....	Foundation Office College Advancement Building 301-784-5200
Student Housing .....	Area Coordinator for Student Housing 301-784-5638 ( <i>Willowbrook Woods Clubhouse</i> )  Director of Residence Life College Center, CC-155 301-784-5368  Student Affairs Business Manager College Center, CC-152 301-784-5206  Office of Student & Legal Affairs College Center, CC-152 301-784-5206
Student Life (Activities, Student Government, Clubs) .....	College Center, CC-160 301-784-5205
Trio/Student Support Services .....	Pathways for Success Humanities Building, H-57 301-784-5630
Tutoring (Cumberland Campus) .....	Student Success Center Humanities Building, H-58 301-784-5551

Regular Hours of Operation: Monday through Friday, 8:00 a.m. - 4:00 p.m. (Memorial Day to Labor Day)  
and 8:30 a.m. - 4:30 p.m. (Labor Day to Memorial Day).

# INTRODUCTION TO ALLEGANY COLLEGE OF MARYLAND



Allegany College of Maryland, founded in 1961, is a publicly supported co-educational community college providing numerous career, technical, transfer, general education, and continuing education programs. Our students receive Associates Degrees, Certificates, Letters of Recognition, and Transfer Credits; many students pursue specific credit and non-credit classes for career development and personal enrichment.

The College consists of three campuses: the main campus in Cumberland, Maryland; the Bedford County campus in Everett, Pennsylvania (established

in 1990); and the Somerset County campus in Somerset, Pennsylvania (established in 1989). The College also manages multiple teaching sites including the Bedford County Technical Center; the Gateway Center in downtown Cumberland which houses the Culinary Arts, Hotel & Restaurant Management, and the Hospitality Management programs; and Garrett County Memorial Hospital in Oakland, Maryland which graduates a cohort of twenty registered nurses every other year. Also, the College offers a wide variety of online and distance learning classes/programs, as well as extensive early college opportunities in local high schools.

Allegany College of Maryland's Continuing Education programs attract nearly 14,000 registrants each year. To help students succeed personally and professionally, Continuing Education offers a wide array of classes in business, health and human services, wellness, professional development, workforce training, and personal enrichment. With opportunities offered at all three campus locations, Continuing Education offers countless options through customized contract trainings, open enrollment courses, professional conferences, certification and licensure courses, and job entry and advancement trainings.

The College is approved for operation by the Maryland Higher Education Commission in Annapolis (Maryland) and is accredited by the Commission on Higher Education, Middle States Association of Colleges & Schools in Philadelphia (Pennsylvania). Local governance is provided by the College's Board of Trustees – appointed members of the local community (Allegany County, Maryland); Allegany College of Maryland is proud to have a highly engaged and inspired Board membership: Kim Leonard (Chair), Jane Belt (Vice-Chair), Joyce Lapp, John J. McMullen Jr., James Ortiz, James R. Pyles, and Barry Ronan.

This Student Handbook details the many opportunities, services, policies, and procedures that make Allegany College of Maryland the quality institution it has always been and will continue to be. Be sure to keep your Student Handbook in a convenient location for easy reference about all things ACM!

Allegany College of Maryland is a community resource, proud to contribute to the growth of Allegany County and the Tri-State Area, through the development of Pennsylvania Campuses in Bedford and Somerset Counties.

Allegany College of Maryland is accredited by the Commission on Higher Education, Middle States Association of Colleges and Secondary Schools, and approved by the Maryland Higher Education Commission.

Allegany College of Maryland supports the efforts of the State of Maryland and the United States to provide learning centers and workplaces free of illegal drug and alcohol use. The Code of Student Conduct includes provisions making unlawful use or possession of drugs or alcoholic beverages a violation of the Code. In addition, the use of oral tobacco or tobacco substitute products or smoking, or the carrying of any lighted tobacco product or tobacco substitute is prohibited in all interior areas of all campus buildings and in all College vehicles. Violators are subject to discipline which might include censure, restitution, probation, suspension, dismissal, or expulsion. In addition, some of the financial aid programs made available through Allegany College of Maryland or through the State of Maryland require certification that the student recipient remain drug free and avoid the unlawful use of alcohol. Conviction of an alcohol or drug violation in a court or under the College Code of Student Conduct could mean loss of valuable financial aid or scholarships. All college students are encouraged to become familiar with the Code of Student Conduct, the College Drug/Alcohol Abuse Policy, and the College Tobacco Use Policy, each of these policies are found in this Student Handbook. If help is needed, the College's drug and alcohol information booklet can be obtained from the Office of the Dean of Student & Legal Affairs or from the College's website at [www.allegany.edu](http://www.allegany.edu).

A report on Allegany College of Maryland's Campus Security Policies and Crime Statistics (34CFR Part 668) and the Clery Act, 20 U.S.C. 1092 (a) and (b) in accordance with the FBI Uniform Crime Reporting (UCR)/National Incident-based Reporting System (NIBRS) is available in the Dean of Student & Legal Affairs' Office (College Center Building room 152) or from the College's website at [www.allegany.edu](http://www.allegany.edu).

Allegany College of Maryland does not discriminate against any individual for reasons of race, ethnicity, color, sex, religion or creed, sexual orientation, gender identity or expression, national origin, age, genetic information, familial status, disability or veteran status in the admission and treatment of students, educational programs and activities, scholarship and loan programs, or to terms and conditions of employment, including but not limited to, hiring, placement, promotion, termination, layoff, recall, transfer, leave of absence, compensation and training. Allegany College of Maryland complies with applicable state and federal laws and regulations prohibiting discrimination and Maryland prohibits retaliation in any form against any person who reports discrimination or who participates in an investigation.

Allegany College of Maryland prohibits sexual misconduct and sex discrimination by or against all students, employees, and campus guests. If you have any questions or concerns or if you need to make a complaint, contact ACM's Title IX Coordinator, Dr. Renee Conner in CC-152, by email at [rconner@allegany.edu](mailto:rconner@allegany.edu), or by phone at (301) 784-5206. For detailed information about policy, procedures, and prevention education, see [www.allegany.edu/titleIX](http://www.allegany.edu/titleIX).

Allegany College of Maryland provides information about its programs, policies, procedures, schedules, and services in numerous publications and mediums including, but not limited to, catalog, handbooks, marketing materials, applications, web sites, and social media. This information is offered for general guidance and shall not be construed as a contract – express or implied – between the College and any person. Students and other individuals are responsible for obtaining the most current, accurate, and complete information from the appropriate College official or other authoritative source. The College reserves the right to modify, supplement, or replace any provision(s) with or without prior notice. The College is not required to offer alternatives or exceptions to any such changes. Unless otherwise stated in writing, all such changes are effective when made and apply to both prospective students and currently enrolled students.

Online links or references to other materials and information provided in the above-referenced sources are also for informational purposes only and do not constitute the College's adoption or endorsement of any products or services referenced.

# STRATEGIC PRIORITIES

## *Our Vision*

---

Allegany College of Maryland will embrace the dynamic spirit of learning for life!

## *Our Mission*

---

Allegany College of Maryland is a lifelong learning community dedicated to excellence in education and responsive to the changing needs of the communities we serve. Our focus is the preparation of individuals in mind, body, and spirit for lives of fulfillment, leadership, and service in a diverse and global society. We are committed to engaging students in rich and challenging learning opportunities within a small college atmosphere that is known for its personal touch.

## *Our Values*

---

QUALITY	<i>We improve through assessment.</i>
INTEGRITY	<i>We promote honesty and trust.</i>
RESPECT	<i>We foster dignity and worth.</i>
OPPORTUNITY	<i>We provide innovative choices.</i>
WELLNESS	<i>We promote healthy lifestyles.</i>

## *Our Goals*

---

- \*\* To provide convenient geographical access to post-secondary education to people within the service region of the college.
- \*\* To provide quality education and services, in a safe and comfortable environment, at a reasonable cost.
- \*\* To support an environment that promotes quality teaching and learning.
- \*\* To promote a college that enhances lives and the community through education and service.
- \*\* To instill in our students a philosophy of life-long learning.
- \*\* To foster a pro-learning campus environment that embraces the values of Allegany College of Maryland.
- \*\* To develop the technical competence and knowledge and other essential skills that prepare students for direct entry into the workforce, for career change and advancement, or for transfer to another college or university.
- \*\* To continually assess our programs and services in order to promote and encourage continuous improvement.

## A MESSAGE FROM THE PRESIDENT

Welcome to the 2015-16 academic year at Allegany College of Maryland. I congratulate you on your decision to pursue your educational goals. Whether you are a new or returning student, all of us at ACM look forward to providing you with an outstanding educational experience that will benefit you for a lifetime.

Allegany College of Maryland has a long history of serving the educational and training needs of the region. Whether you are seeking an affordable route to a bachelor's degree, credentials for the workplace or personal enrichment, ACM has something to offer you. Here you will find many opportunities to acquire the education that you need to achieve your personal and career goals.

The College is proud of the many modern and beautiful facilities which provide an ideal environment for learning. Our caring faculty and staff are committed to your success, whatever your goals may be. I encourage you to make the most of the many resources available to you.

Take the first step toward your success by exploring this student handbook. Inside of these pages, you will find basic information about the College's programs, services and activities. Should you find that you have additional questions, please contact us. Our faculty and staff are here to assist you with answers.

My best wishes for a successful year!

Sincerely,



Cynthia S. Bambara, Ph.D.  
President

## **A MESSAGE FROM THE DEAN OF STUDENT & LEGAL AFFAIRS**

To students both new and returning to Allegany College of Maryland, we are glad you are here. Congratulations on your accomplishments so far; there are many more to come. Our college's faculty and staff are committed to helping you achieve your dreams while you study and prepare for tomorrow. We also want you to enjoy today.

I urge you to read this Student Handbook carefully and to keep it in a convenient place or bookmarked in your web browser. It contains a wealth of information to guide your success at Allegany College of Maryland– from academic criteria to computer/internet use to library hours to student clubs to disciplinary procedures. Consult its pages for **answers** to questions (large and small) and for **ideas** to enrich your campus life. Allegany College of Maryland has much to offer you, and we are confident you will have valuable contributions to make on your campus.

As a college student, your first priority is to obtain a meaningful education. Learning occurs both inside and outside the classroom; Student & Legal Affairs' mission focuses on the learning that occurs outside the classroom. Every experience is an opportunity to develop and grow. We are here to help you and urge you to visit our offices: Athletics, Campus Kids Child Care, Student Life & Diversity, Residence Life, and Dean. We welcome your input, suggestions, and questions. We want you to get involved. Each campus is a reflection of the lives lived upon it, and you can leave your mark for both your peers and future generations.

Wishing you a terrific year,



B. Renee Conner, J.D.  
Dean of Student & Legal Affairs

**Allegany College of Maryland • Student & Legal Affairs**  
**EXPECTATIONS**

Our Mission: Allegany College of Maryland is a lifelong learning community dedicated to **excellence in education** and responsive to the changing needs of the communities we serve. Our focus is the preparation of individuals in mind, body, and spirit for lives of **fulfillment, leadership, and service** in a diverse and global society. . . . .

**EXPECTATION #1: Attend Class.** Go to each of your classes each time it meets. Be on time, and stay for the entire class session. If you must miss class because of illness or emergency, check your course syllabus to know the instructor's attendance policy. Make up any missed work promptly. (It is vitally important that you read each course syllabus! It contains what you need to know to be successful in that class; it also tells you what each individual instructor's expectations are.)

**EXPECTATION #2 Do the Work.** It is true that for every hour you spend in class you should study two hours outside of class. (If you are taking 12 credits, you should be studying/doing homework 24 hours each week.) Read each assignment. Turn in your homework when it is due.

**EXPECTATION #3: Ask for Help.** If you are having problems with a class or an assignment, help is available. See the instructor. Go to the Student Success Center for a tutor. Form a study group with classmates. Meet with your advisor. But don't wait until it is too late! Waiting until the final weeks of a semester is unlikely to help.

**EXPECTATION #4: Read the Handbook.** The Student Handbook is full of useful information to help you negotiate the often-roiling waters of college life. It also details the responsibilities of campus citizenship. (Ignorance of the rules is NOT an excuse for breaking them.) The answer to virtually any question you have about Allegany College of Maryland is in this Handbook.

**EXPECTATION #5: Respect Others.** One of the College's Core Values is Respect. Showing respect means many things, including being courteous in the classroom, hallway, library, cafeteria, courtyard, parking lot – anyplace you encounter other people. Respect also means treating others as you would like to be treated; insulting, humiliating, judging, or ignoring another person hurts feelings. Shouting and cursing are always inappropriate in a learning environment.

**EXPECTATION #6: Be Responsible.** We trust that you meet all obligations that are part of attending college. As an adult, you must learn to read all notices given to you, mailed to you, or posted for you to read, to show up for work study assignments, to pay your bills on time, and to manage problems/issues yourself without demanding special treatment or immediate gratification.

College is about more than merely attending classes and getting grades. College is about finding and creating opportunities to grow. It is about learning independence, making your own decisions, and becoming a community citizen. We are here to help you learn those things, too.

We promise to treat you with respect, to give you quality education, to act with integrity, to provide you with opportunities to learn and to grow as a person, and to promote wellness in mind, body, and spirit.  
That's our part. You must do yours.



# TABLE OF CONTENTS

	Page
STUDENT SERVICES QUICK REFERENCE GUIDE .....	2
<b>SECTION ONE: <u>GENERAL INFORMATION</u></b>	
I. Student Affairs .....	15
A. Orientation .....	15
1. Cumberland Campus .....	15
2. Pennsylvania Campuses .....	15
B. Health & Safety .....	15
1. Infectious Diseases .....	15
2. Alcohol, Drugs and Other Intoxicants .....	16
3. Tobacco/Smoking.....	16
4. First Aid Kits.....	16
5. e-SAFE .....	16
6. Medical Care & Counseling .....	17
7. Security/Safety .....	18
8. Criminal Activity .....	19
9. Sexual Misconduct & Sex Discrimination.....	20
10. <i>Clergy Act</i> and Reporting Requirements.....	23
11. <i>Clergy Act</i> and Timely Warnings .....	23
12. Student Discipline – ( <i>See Section Eight</i> ) .....	24
13. Cooperation with Law Enforcement Officials .....	24
C. Student Photo Identification (ID) Cards.....	24
D. Residency .....	24
E. Student Life .....	27
1. Introduction .....	27
2. Student Government Association .....	27
3. Student Clubs/Organizations .....	28
4. Procedures for Recognition of Student Organizations.....	29
5. Student Communication.....	31
6. Student Publications.....	31
7. Fundraising and Sales.....	31
F. Athletics, Intramurals & Recreation.....	32
1. Eligibility Rules of NJCAA Intercollegiate Athletics.....	33
2. Title IX of the Education Amendments of 1972 .....	33
G. First Amendment Policy .....	33
H. Student Communication Policy .....	34
I. Student Housing.....	35
J. Off-Campus Housing .....	36
K. Campus Kids Child Care Center .....	36
L. Center for Diversity & Student Engagement .....	37
M. Calendar of Events .....	37
N. Special Needs Students.....	37
O. Voter Registration .....	38
P. Using Public Transportation .....	38
II. Library .....	38
A. Special Collections .....	39
B. Library Services .....	39
C. Borrowers .....	39
D. Loan Periods.....	39

E.	Fines for Overdue and Lost Materials .....	39
F.	Cumberland Campus Library Hours .....	40
G.	Pennsylvania Campus Library Information and Hours .....	40
H.	Courtesy in the Library .....	41
I.	Conference Room Usage .....	42
III.	Bookstore.....	42
A.	Hours of Operation .....	42
B.	Procedure for Buying Books .....	42
C.	Paying by Check/Credit Card .....	42
D.	Purchase of Books via Financial Aid.....	42
IV.	Information Technology.....	43
A.	Computer Labs for Students .....	43
B.	Lab Hours.....	43
C.	Student HelpDesk.....	43
D.	Technology Resources Policy .....	43
E.	Student Communication Policy .....	46
V.	Food Services .....	47
VI.	Information Center.....	47
VII.	Inclement Weather/College Closing Policy .....	47
VIII.	Special Information for Students at Somerset and Bedford Campuses .....	49
	<i>(See also PA directory in Section Eleven)</i>	

## **SECTION TWO: REGISTRATION FOR COURSES AND ADDING/DROPPING COURSES**

I.	Registering for Courses .....	51
II.	Adding a Course .....	51
III.	Dropping a Course .....	51
IV.	Repeating a Course .....	51
V.	Accessing Information Using WebAdvisor.....	52
VI.	Veteran’s Affairs.....	52

## **SECTION THREE: STUDENT FINANCIAL AID**

I.	Information and Policies .....	54
----	--------------------------------	----

## **SECTION FOUR: FOUNDATION SCHOLARSHIP PROGRAM**

I.	Cumberland Campus.....	57
II.	Somerset County Campus .....	58
III.	Bedford County Campus .....	59

## **SECTION FIVE: ACADEMIC INFORMATION**

I.	Student Success Center .....	60
A.	Placement Assessment .....	60
B.	Academic/Transfer Advising .....	60
C.	Tutoring .....	61
D.	Testing Lab/Classroom Testing .....	62
E.	Career Services.....	62
F.	College Level Examination Program (CLEP) .....	63
II.	Disability Resources .....	63
III.	Distance Learning .....	64
A.	Interactive Video Courses .....	64
B.	Web (online) Courses .....	64
C.	Blended Courses.....	64
IV.	Pathways for Success (Trio/Student Support Services) .....	64

A. Eligibility .....	64
B. Program Services .....	64
C. Enrollment Process .....	65
V. Cheating/Plagiarism .....	65
VI. Non-Traditional Student Services.....	65
VII. Some Notes on Academic Success .....	66
Guidelines for Students from Faculty .....	66

**SECTION SIX: ACADEMIC REGULATIONS.....68**

**SECTION SEVEN: GRIEVANCE POLICIES AND PROCEDURES FOR STUDENTS**

I. Academic Grievance Procedure .....	83
II. Employee Complaint/Misconduct Policy .....	84
III. Procedure for Appealing Denial of College Service(s) .....	85
IV. Reporting Other Concerns .....	86

**SECTION EIGHT: CODE OF STUDENT CONDUCT**

I. Philosophy.....	90
II. Authority .....	90
III. Jurisdiction .....	90
IV. Standard of Conduct and Policies .....	91
A. Personal Interaction .....	91
1. Assault and Battery .....	91
2. Aggravated Assault .....	91
3. Threat/Intimidation .....	91
4. Sexual Assault.....	91
5. Sexual Harassment .....	91
6. Harassment .....	91
7. Bullying.....	91
8. Other/Violations of law .....	91
Policy: Sexual Misconduct & Sex Discrimination .....	91
B. Respect for Property .....	93
1. Theft/Unauthorized Use .....	93
2. Trespassing .....	94
3. Unauthorized Entry .....	94
4. Breaking and Entering .....	94
5. Robbery .....	94
6. Vandalism.....	94
7. Other/Violations of law .....	94
C. Health and Safety .....	94
1. Weapons.....	94
2. Disregarding Fire Safety .....	94
3. Drugs .....	94
4. Alcohol .....	94
5. Tobacco/Smoking Policy.....	94
6. Reckless Endangerment.....	94
7. Child Endangerment .....	94
8. Enabling Dangerous Persons .....	94
9. Unauthorized Possession/Duplication of Keys.....	94
10. Traffic Obstruction .....	94
11. Unsafe Driving .....	95
12. Unauthorized Parking .....	95

13. Animals.....	95
14. Spreading Infectious Disease.....	95
15. Other/Violations of law.....	95
Policy: Alcohol & Drug Use.....	95
Policy: Tobacco and Smoking.....	95
Information: Littering.....	97
Policy: Unattended Children.....	97
Policy: Dangerous Persons on Campus.....	97
Policy: Pets and Animals.....	98
Policy: Infectious Diseases/Conditions.....	98
D. Peace and Order.....	98
1. Failure to Comply.....	98
2. Probation Violation.....	98
3. False Statements.....	98
4. Fraud.....	98
5. Disorderly Conduct.....	98
6. Inappropriate/Unauthorized Use of Computer(s).....	98
7. Residence/Residency.....	99
8. Unauthorized Publication(s)/Sale(s).....	99
9. Other/Violations of law.....	99
Information: Classroom Behavior.....	99
Policy: Use of Cellular Telephones.....	99
Policy: Technology Resources Policy.....	99
Policy: Student Publications and Sales.....	99
E. Housing Regulations.....	99
V. Enforcement of Policies.....	100
VI. Student Discipline.....	100
A. Misconduct.....	100
1. Offenses against another person.....	100
2. Offenses against property.....	100
3. Offenses against health and safety.....	100
4. Offenses against peace and order.....	101
5. Offenses against Housing.....	101
B. Disciplinary Procedures.....	101
1. Reporting.....	101
2. Initiation of Discipline.....	101
3. Notice.....	101
4. Investigation.....	102
5. Hearing.....	102
6. Deliberation.....	102
7. Decision.....	103
8. Sanctions.....	103
a. Censure.....	103
b. Fine.....	103
c. Educational Sanction.....	103
d. Probation.....	103
e. Suspension.....	103
f. Dismissal.....	103
g. Expulsion.....	103
9. Appeal.....	103

10. Appeal Procedures .....	104
-----------------------------	-----

**SECTION NINE: FERPA**

I. The Family Educational Rights and Privacy Act (FERPA) Policy .....	107
---	-----

**SECTION TEN: COMMON QUESTIONS ABOUT ACM**

**Questions Relating to Academics**

1. What does it mean to be a <b>full-time student</b> ? .....	110
2. What is a <b>credit hour</b> ? .....	110
3. What is a <b>a program of study</b> ? .....	110
4. <b>How much time must I spend for a course</b> in addition to time spent in the classroom (homework, class preparation, etc.)? .....	110
5. Does the College have an <b>attendance policy</b> ? .....	110
6. How do I interpret my <b>grade report</b> ? .....	110
7. <b>What grades are assigned if I stop coming to classes</b> during a semester or summer term?.....	111
8. What is a <b>quality point</b> on my grade report?.....	111
9. How do I compute my <b>semester quality report average</b> ? .....	111
10. What is the difference between semester quality point average and cumulative quality point average? .....	112
11. What <b>academic honors and programs</b> exist for outstanding students? .....	112
12. When is a student placed on <b>academic probation or suspended academically</b> ?.....	112
13. What is a <b>prerequisite</b> ? .....	112
14. What is an <b>elective</b> ? .....	113
15. What are the minimum requirements for <b>graduation</b> ?.....	113
16. What is the role of an <b>academic advisor</b> ? .....	113
17. What do I do if an <b>instructor does not show up for class</b> ? .....	113
18. Do I need to let the College know if I <b>change my address or phone number</b> ? .....	113

**Questions Relating to Student Life**

19. Is there <b>health insurance</b> available to students? .....	114
20. Where can students access <b>health care</b> in Cumberland?.....	114
21. What services are available to students from the <b>Dental Hygiene Department</b> ? .....	114
22. How do I obtain a <b>locker</b> on the main campus? .....	114
23. Can students cash <b>personal checks</b> on campus? .....	114
24. Is there <b>public transportation</b> available for the main campus? .....	114
25. Are <b>childcare services</b> available to main campus students? .....	115
26. How can I keep informed about the College after I graduate or transfer? .....	115
27. What services are available to students from the Therapeutic Massage Program? .....	115
28. What services are available to non-traditional students? .....	115
29. What do I do if I witness an assault or crime?.....	115
30. What do I do if I am a victim of sexual misconduct or sex discrimination?.....	115

**SECTION ELEVEN: NAVIGATING ACM**

I. Directories .....	116
A. Directory of Student Services Personnel .....	116
B. Directory of Instructional Department Heads .....	121
C. Pennsylvania Campuses Information .....	124
II. College Calendar .....	126
III. Floorplans .....	129
IV. Notes Pages .....	147
V. Campus Map .....	148

# Student & Legal Affairs

at Allegany College of Maryland

Campus Kids Child Care Center, Counseling, Diversity Center, Legal Issues, Student Discipline, Student Housing, Student Life, and Student Services.

*Student and Legal Affairs relies upon the College's mission statement as a reference point whenever we undertake new projects or make decisions on unfamiliar matters.*

*The mission of Student and Legal Affairs is to educate students on life issues outside the classroom, to cultivate a safe learning environment, and to assist students in becoming well-rounded, responsible adults.*

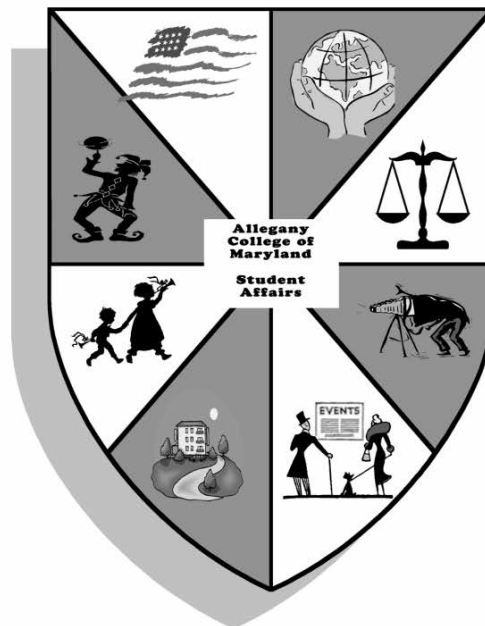



## **SECTION ONE: GENERAL INFORMATION**

### **I. Student Affairs**

The mission of Student Affairs is to educate students on life issues outside the classroom, to cultivate a safe learning environment, and to assist students in becoming well-rounded, responsible adults. The following pages reveal the breadth of Student Affairs—from getting students started their first day to providing extra-curricular activities to promoting wellness in mind, body, and spirit to keeping the campus informed to making 236 homes and more. If you need help outside the classroom, we either offer it or can help you find the people who do.

#### **A. Orientation**

##### **1. Cumberland Campus**

All incoming, first-semester students are strongly encouraged to participate in an orientation program.

The purpose of these orientations is to inform students about academic, social, and general College policy affecting their participation as students in the College. Information is distributed at appropriate times in order to give adequate advance notice.

\* There is also a mandatory orientation for all students residing in housing.

##### **2. Pennsylvania Campuses**

New student orientation programs at the Pennsylvania Campuses are conducted during the fall and spring semesters. The programs include group discussion on the following topics: study skills, classroom concerns, financial aid, admissions/registration, and transfer information. All incoming, first-time students will be notified of the date and time for each respective campus. Parents are encouraged to attend.

#### **B. Health & Safety**

##### **1. Infectious Diseases**

This policy concerns infectious diseases/conditions that include (but are not limited to) measles, chickenpox, other rashes with fever, lice, hepatitis, flu pandemic, impetigo, pink eye, jaundice, and the like.

In an effort to protect the health and welfare of students, staff, and faculty at Allegany College of Maryland, students, staff, faculty, and their children who exhibit signs and symptoms of potential, acute communicable illnesses may **not** remain on campus and will be excluded from public areas, classrooms, laboratories, college offices, and housing until the acute and/or contagious stage is over. (That determination must be made by a physician or Health Department official, who must provide written verification.) Exclusion from campus during this period will not only facilitate the recovery of the affected person, but it will also protect other from possible transmission to other persons, particularly those whose immunity to disease is already compromised (e.g., persons undergoing treatment for leukemia and other forms of cancer).

---

Please note: Unless otherwise indicated, the words "Allegany College of Maryland," "Campuses of Allegany College of Maryland," "The College," shall be understood to incorporate all three campuses of the College: Main Campus, Cumberland; Somerset County (PA) Campus, and the Bedford County (PA) Campus.

## Section One: General Information

It is the responsibility of the infected individual to notify the Dean of Student & Legal Affairs\* of the illness. The person will be asked to provide essential information such as when the illness/condition was contracted, from whom the illness/condition was contracted, and with whom the infected person has had contact. The Dean of Student & Legal Affairs will coordinate any campus-wide response that is needed with the appropriate officials (e.g., Health Department officials, the Wellmobile, the Vice President of Finance and Administration, the Senior Vice President of Instruction and Student Affairs, the Director of Residence Life, etc.) *If necessary, Allegany College of Maryland will close until the medical crisis has passed.*

\*On the Pennsylvania campuses, the Director of Student Services will accept notification and coordinate response.

Assuming hospitalization or other quarantine is not required, students will be encouraged to go to their permanent homes during this time and to contact their instructors to make arrangements for their assignments, tests, and other academic obligations. Please consult the relevant section of this Handbook and course syllabi for attendance policies

### 2. Alcohol, Drugs and Other Intoxicants

ACM has clear policies about the use and possession of alcohol and drugs (including any other intoxicant or mind-altering substance). With extremely limited exceptions, alcohol/drugs are strictly prohibited on college property. See the Code of Student Conduct (Section 8 of this Handbook) and the Alcohol/Drug Abuse Resource Manual\* for details.

\*Obtained in the Office of Student & Legal Affairs and online at [www.allegany.edu](http://www.allegany.edu)

### 3. Tobacco/Smoking

Effective 8/19/2013, ACM is a smoke-free and tobacco-free college. Smoking and the use of any tobacco or tobacco substitute product (including but not limited to vapor products) is strictly prohibited on ACM property. See the Code of Student Conduct (Section 8 of this Handbook) for details.

### 4. First Aid Kits

Sixteen departments throughout the College (or each building of the main campus of Allegany College of Maryland) have a First Aid Kit that is purchased, maintained, and kept current by Campus Security. If you are in need of minor attention (i.e. scrapes, cuts, bee stings, etc.) please go to a faculty/staff office and someone can assist you in locating the closest First Aid Kit. For medical emergencies, call 911.

If you are in need of minor attention at one of the PA Campuses, please go to a faculty/staff office and someone can assist you in locating a First Aid Kit.

### 5. Emergency Text Messaging Service

**e-SAFE** (electronically sending announcements for emergencies such as weather-related closures/delays, safety issues, and more) is an alert system that allows Allegany College of Maryland to contact you during an emergency by sending text messages to you:

- E-mail (school, personal, other)
- Cell phone
- Pager
- BlackBerry

When an emergency occurs, authorized senders will instantly notify you using **e-SAFE**. **e-SAFE** is your personal connection to real-time updates, instructions on where to go, what to do, or what not to do, who to contact and other important information.





**We strongly encourage students to register**—it takes only a minute. This will be the surest way for you to receive public safety and/or college closing notifications.

New users may register by visiting the Allegany College of Maryland web site. Click on the **e-SAFE** logo.

**e-SAFE** is a free service offered by Allegany College of Maryland. Your wireless carrier may charge you a fee to receive messages on your wireless device.

## **6. Medical Care & Counseling**

### **Medical Care**

Allegany College of Maryland does not operate its own health center. Since ACM is a community college, many students already have a local doctor, dentist, or other medical provider, but for other students, the College maintains a list of local health care providers (ie., clinics) to which students may be referred for general or specific medical issues. Allegany College of Maryland does not endorse or recommend any of these health care providers. The list is provided simply as an informational service. It is the student's responsibility to choose his/her own provider and to pay for all medical services. Additionally, each county in our service region has a Health Department which provides numerous medical services/programs. The Cumberland campus is next-door to the Allegany County Health Department and across the street from the hospital: Western Maryland Regional Medical Center (a facility of Western Maryland Health System).

### **Nurse-Managed Wellness Center**

The Nurse-Managed Wellness Center offers educational experiences for nursing and allied health students. The NMWC is located on the first floor of the Allied Health Building (room 115). Services offered during the Fall and Spring semesters include influenza vaccinations, Tuberculosis (PPD) screenings, cholesterol and blood sugar screenings as well as health education on a variety of topics. (NOTE: NMWC is not a health care clinic!) A full list of services with dates and times is available at NMWC (301) 784-5670 and online.

### **Counseling**

Allegany College of Maryland offers comprehensive counseling services for its students – free of charge. We know that the academic pressures of being a college student and the challenges students face in their personal lives can interfere with academic success. Allegany College of Maryland is committed to supporting students, faculty, and staff *when life sometimes gets in the way*. For detailed information, contact the Office of Student & Legal Affairs in CC-152 or by phone (301) 784-5206.

#### Counseling Program Components

##### 1. Personal Counseling:

Allegany College of Maryland contracts with **APPALACHIAN BEHAVIORAL HEALTH CENTER & WESTERN MARYLAND HEALTH SYSTEM** (Cumberland) to provide counseling to individual students. Any eligible student is entitled to receive up to five (5) hours of counseling per semester for any mental health issues with which s/he needs assistance. Counselors are also available for urgent and crisis situations. Couples and family counseling are also available. All services provided by the ABHC & WMHS are completely confidential and provided by qualified, licensed mental health professionals. Detailed brochures about the Counseling Program are available in racks all over campus or from the S&LA Office.

ABHC can be reached by calling (301) 724-7277; WMHS can be reached by calling (240) 964-8585. (The Pennsylvania campuses contract separately with MH/MR; for more information, contact Student Services offices in Bedford at (814) 652-9528 ext.6202 and in Somerset at (814) 445-9848 ext.6106.)

## **Section One: General Information**

### **2. On-Site Campus Counselor:**

To supplement the traditional counseling program, Allegany College of Maryland will establish a second contracted service to provide an additional, routine presence on campus to assist any student who is in crisis, to offer therapeutic problem-solving, to make referrals for personal counseling, and to provide educational/outreach programs. This new partner will be a qualified, properly licensed counselor who understands the community college culture, the unique needs of ACM students, and the campus qualities that make ACM special. The partner will be on campus in the Diversity Center on dedicated days approximately 10 hours per week during the fall and spring semesters.

### **3. Family Crisis Resource Center:**

Alligany College of Maryland has partnered with the Family Crisis Resource Center (Cumberland) to provide easily accessible domestic violence and sexual assault support services to students. FCRC is a non-profit, nongovernmental sexual assault and domestic violence victim services organization. FCRC provides a Coordinator of Services *on campus* twice per week. The Coordinator will be available to any ACM student [or employee] who has experienced past or present domestic violence, dating violence, child abuse, sexual abuse, rape, sexual assault, incest, or stalking. This free service is provided in the Diversity Center on dedicated days approximately 8 hours per week during the fall and spring semesters.

### **4. Mental Health First Aid**

Drs. Renee Conner and June Bracken were certified in March 2014 for the nationally recognized program known as Mental Health First Aid. Mental Health First Aid teaches the basic knowledge and skills to respond to an individual in distress. Drs. Conner and Bracken were certified both as mental health “first aiders” and as instructors to teach the program. They will offer at least three classes throughout the academic year to Allegany College of Maryland employees who wish to be certified as mental health “first aiders”. By providing employees with valuable skills to manage distressed students and to know what to do if a student is in crisis, ACM is helping both the students who have a mental health problem as well as the employees who have reported feeling under-qualified to respond to such situations. College employees who have completed the training receive a koala sticker to place on their doors or desks so they can be identified as a mental health “first aider”. If/when you or someone you know is in distress, **look for the Koala!!**

### **5. Screening for Mental Health**

Alligany College of Maryland is registered with College Response to purchase online screening programs for depression, generalized anxiety disorder, PTSD, bipolar disorder, alcohol/drug use disorders, and eating disorders. These personal assessments can be completed by any student from any internet connection; if the results indicate treatment or services may be needed, you will be given appropriate referral information.

### **6. Medical or Mental Health Emergencies:**

Any person who witnesses a medical or mental health emergency requiring immediate intervention should **CALL 911 AND THEN CALL CAMPUS SECURITY @ X.5555**. Health and safety are too important to hesitate, and you do not need permission to call 911.

### **7. Security/Safety**

Alligany College of Maryland is committed to ensuring a safe environment for students, faculty, staff and visitors. The college's Security Department has primary responsibility for serving the safety and security needs of the campus community. Campus buildings and facilities are patrolled and inspected regularly to ensure a safe and comfortable academic environment. Every effort is made to fulfill any request for service. The Security Department realizes security is also an individual responsibility and strives to educate the campus community about personal and public safety. The Security Department works closely with the administration, student affairs, housing, and staff of the physical plant to ensure a safe environment. In addition, the Security Department works closely with the Cumberland Police and Fire Departments to promote personal safety.

The Security Department and the Office of Student Affairs ensures full disclosure of campus security information in compliance with the legal requirements of the Jeanne Clery Act. The annual report containing crime statistics is available in the Office of Student Affairs and online at [www.allegany.edu](http://www.allegany.edu). The Public Crime Log is available in the Security Office and can be viewed during normal business hours.

\*The Security Department is located in the College Center of the Cumberland Campus, Room 160. The office phone number is (301) 784-5252 or dial 5252 from any campus network phone. For emergencies, call (301) 784-5555 or dial 5555 from any campus network phone.  
**Or call 911.**

### **Personal Safety**

Allegany College of Maryland welcomes thousands of students and visitors to its campuses each year to enroll in credit and non-credit classes, to enjoy athletic and cultural events, to use recreation facilities, to conduct research in the Library, to dine in the cafeteria, to attend meetings, and much more. College faculty and staff are committed to making each campus environment functional and safe. Campus security is highly capable of handling many emergencies and has direct communication with the Cumberland City Police. Maintenance personnel are vigilant to correct any obstructions or damages to College property. Nevertheless, given the high volume of traffic and the extensive hours of operation, accidents and acts of misconduct are inevitable.

Happily, Allegany College of Maryland has a low rate of both accidents and crime. We strive to keep it that way, and we emphasize prevention as an essential tool for everyone's personal safety.

Please observe the following practices whenever you are on campus:

- Always be aware of your surroundings.
- Avoid walking in areas that are isolated, poorly lit, unpaved, or containing debris/equipment.
- Do not walk alone at night. Walk in groups or call Security for an escort to your car.
- Do not leave populated areas with someone you do not know extremely well.
- If you feel uncomfortable or suspicious of a person or situation, get away!
- Do not leave your personal property unattended at any time, in any location.
- Keep a separate record of valuables (including serial numbers).
- Always lock your car, locker, and apartment door.
- Protect personal information such as social security number, locker combination, PIN numbers, etc.
- Make sure someone (a friend or relative) knows your schedule and travel habits.
- Evacuate buildings if you hear a fire alarm OR are directed by an official.
- Report dangerous situations, accidents, and crimes immediately to Police, not Security.

If there has been an accident with injuries, call 911 and Security (ext. 5555).

If there has been an accident without injuries, call Security\*.

If there has been a crime with injuries, call 911 and Security (ext. 5555).

If there has been a crime without injuries, call the police, Security\*, and the Dean of Student & Legal Affairs.

\*Incidents on the Pennsylvania campuses shall be reported to the Admissions/Registration Offices.

## **8. Criminal Activity**

The College strives to maintain a safe environment for students to learn, for faculty to teach, and for administration and staff to work by (1) having policies and procedures which may prevent crime, (2) reporting crimes to local law enforcement and assisting with those investigations, (3) initiating disciplinary action for any crimes committed by students, and (4) banning unsafe persons from campus. If you are the victim of a crime or if you have information about the commission of a crime, please report the crime immediately.

- Always call 911 in an emergency.
- Contact Campus Security at (301) 784-5555
- Contact Cumberland Police Department at (301) 777-1600.
- You may also report by contacting the Office of Student Affairs at (301) 784-5206
- You can report anonymously on the Campus Security web page at [www.allegany.edu](http://www.allegany.edu)

## Section One: General Information

In the event of an active shooter on campus, the College will make every effort to issue alerts, warnings, and information to keep students, staff, and visitors safe. According to the Maryland State Police, who have provided direct training to College officials, an active shooter situation is when one or more suspects participate in an ongoing, random, or systematic shooting spree demonstrating their intent to continuously harm others. The best advice is to be vigilant and SEE SOMETHING / SAY SOMETHING! Report anything suspicious or concerning to a College official or to the police, and let the authorities take the appropriate action. Read safety communications from the College, and attend any training/informational opportunities. Sign-up for e-Safe (details above). Follow all laws, rules, policies, and procedures; they exist to help keep you safe. If the worst happens, your goal is to SURVIVE. Evacuate if it is safe to do so; if you cannot safely escape, barricade yourself and hide. If you are discovered, defend yourself. Always follow directions from College and law enforcement officials.

\*This information provided by Maryland State Police's Active Shooter Training at Allegany College of Maryland 4/3/13.

### Emergency and Non-Emergency Contacts:

*"Always give the location of the incident."*

#### Cumberland Campus and the Gateway Center

Emergency:

Call **911** for police, fire, or ambulance then **5555** to report it to campus security for

Non-Emergency (safety/security issues):

Call 5555 (campus phone) for security or **301-784-5555** from off-campus.

#### Bedford County Campus

Emergency:

Call **911** for police, fire, or ambulance then **814-652-9528, ext. 6200 or 814-977-6861** to report it to the physical plant office

Non-Emergency (safety/security issues):

Call **6200** (campus phone) or from off-campus call **814-652-9528, ext. 6218 or ext. 6200**.

#### Somerset County Campus

Emergency:

Call **911** for police, fire, or ambulance then **814-445-9848, ext. 6107 or 814-442-2932** to report it to the physical plant office for Somerset County.

Non-Emergency (safety/security issues):

Call **6107** (campus phone) or from off-campus call **814-445-9848, ext. 6107 or ext. 6100**.

#### Emergency Telephones (Cumberland Campus)

Emergency telephones are conspicuously located at the athletic field/each classroom building, college center, continuing education, gym and library. They are clearly marked and are to be used to call **911** in emergencies and campus security at **5555**.

Locations:

- Allied Health: (2 phones) canteen 1st floor- top of steps 2nd floor
- Athletic Fields: on building right side of rear gym entrance
- Auto Tech: lobby
- College Center: at dining area entrance
- Continuing Education: inside main entrance
- Gym: main lobby
- Humanities: inside main entrance
- Library: lobby
- Science Building: inside southeast entrance
- Tech Building: (2 phones) canteen 1st floor- connecting hall 2nd floor

## 9. Sexual Misconduct and Sex Discrimination

Title IX is federal law that prohibits discrimination against any person on the basis of sex in any education program or activity; sexual misconduct and sexual harassment are forms of discrimination under Title IX. The College's policy and procedures relating to sexual misconduct and sex discrimination include requirements under Title IX, Clery Act, Violence Against Women Act, and other federal/state laws commonly referred to – collectively – as "Title IX"

- ACM prohibits sexual misconduct, sex discrimination, and retaliation.
- ACM's Sexual Misconduct & Sex Discrimination Policy and accompanying procedures comply with all legal mandates. All information related to Title IX compliance may be found at [www.allegany.edu/titleIX](http://www.allegany.edu/titleIX). Topics include: healthy relationships, risk reduction, consent, bystander intervention, rights and responsibilities, interim measures, the complete ACM policy, and much more.
- Any employee with knowledge of sexual misconduct and sex discrimination must report it.

**ALLEGANY COLLEGE OF MARYLAND TAKES SEXUAL MISCONDUCT AND SEX DISCRIMINATION SERIOUSLY.** Sexual misconduct includes but is not limited to the following unacceptable behaviors: rape, sexual assault, harassment, stalking, relationship violence, and attempts to commit such acts. Any person found responsible for sexual misconduct will be properly sanctioned; options that must be considered include removal from on-campus housing, suspension from the College, and dismissal from the College. The College will not permit a hostile environment to exist and will not tolerate retaliation against any person who reports and/or cooperates with an investigation.

Upon receiving a report of alleged discrimination and/or sexual misconduct, Allegany College of Maryland will:

1. Take immediate and appropriate action to stop the misconduct;
2. Take immediate and appropriate action to prevent its recurrence for the safety of the individuals involved as well as the campus generally including the issuance of any essential warnings;
3. Take immediate and appropriate action to address the effects of the misconduct;
4. Provide information to the identified complainant and to the accused perpetrator (if a student or employee) about their rights as well as available resources;
5. Conduct a preliminary inquiry of the complaint;
  - » At the conclusion of the preliminary inquiry, the investigators shall determine if there is reasonable cause (i.e., sufficient substantiating evidence) to proceed and, if so, whether a formal or informal resolution is required.
6. Conduct a prompt, adequate, reliable, and impartial investigation of the complaint where indicated;
  - » At the conclusion of any formal investigation, the investigators shall determine if the accused person violated the Code of Student Conduct (student) or HR policies (employees).
  - » The standard of proof shall be Preponderance of Evidence.
  - » If the accused person is found responsible, an appropriate consequence or sanction shall be imposed.
7. Follow all appropriate procedures as detailed in the Code of Student Conduct, Human Resources Manual, and other related institutional policies;
8. Encourage and support a report to local law enforcement;
9. Cooperate with any criminal investigation/prosecution; and
10. Comply with other legal and policy/procedure requirements.

### Key Terms:

**SEXUAL MISCONDUCT:** an umbrella term that includes Dating Violence, Domestic Violence, Sexual Exploitation, Sexual Harassment, Sexual Intimidation, Sexual Violence, and Stalking.

**SEXUAL VIOLENCE:** a form of Sexual Harassment and refers to physical sexual acts perpetrated without Consent. Sexual Violence includes Rape, Sexual Assault, Sexual Battery, and Sexual Coercion. Sexual Violence, in any form, is a criminal act.

## **Section One: General Information**

SEXUAL HARASSMENT: any unwelcome advance, unwelcome request for sexual favors, or other unwelcome verbal or physical conduct of a sexual nature when (1) submission to or rejection of such conduct is made, either explicitly or implicitly, a term or condition of an individual's employment, evaluation of academic work, or participation in any aspect of an ACM program or activity; (2) submission to or rejection of such conduct by an individual is used as the basis for academic, employment, or activity or program participation related decisions affecting an individual; or (3) such conduct has the purpose or effect of unreasonably interfering with an individual's work or academic performance (ie., it is sufficiently severe or pervasive to create an intimidating, hostile, humiliating, demeaning, or sexually offensive working, academic, residential, or social environment.

SEXUAL ASSAULT I – NON-CONSENSUAL SEXUAL INTERCOURSE: any act of sexual intercourse with another individual without consent. Sexual intercourse include vaginal or anal penetration, however slight, with any body part or object or oral penetration involving mouth to genital contact.

SEXUAL ASSAULT II – NON-CONSENSUAL SEXUAL CONTACT: any intentional touching of the intimate parts of another person causing another to touch one's intimate parts, or disrobing or exposure of another without consent. Intimate parts may include genitalia, groin, breast, or buttocks, or clothing covering them, or any other body part that is touched in a sexual manner. Sexual contact also includes attempted sexual intercourse.

CONSENT: a knowing, voluntary, and affirmatively communicated willingness to mutually participate in a particular sexual activity or behavior. It must be given by a person with the ability and capacity to exercise free will and make a rational and reasonable judgment. Consent may be expressed either by affirmative words or actions, as long as those words or actions create a mutually understandable permission regarding the conditions of sexual activity. Consent may be withdrawn at any time. Consent cannot be obtained by force, threat, coercion, fraud, manipulation, reasonable fear of injury, intimidation, or through the use of one's mental or physical helplessness or incapacity. Consent cannot be implied based upon the mere fact of a previous consensual dating or sexual relationship. Consent to engage in sexual activity with one person does not imply consent to engage in sexual activity with another.

DATING VIOLENCE: violence committed by a person who is or has been in a social relationship of a romantic or intimate nature with the complainant. The existence of such a relationship shall be determined based upon a consideration of the length of the relationship, the type of relationship, and the frequency of interaction between the persons involved in the relationship.

DOMESTIC VIOLENCE: violence committed by a current or former spouse or intimate partner of the complainant by a person with whom the complainant shares a child in common, by a person who is cohabiting with or has cohabited with the complainant as a spouse or intimate partner, by a person similarly situated to aa spouse of the complainant, or by any other person against an adult or youth complainant protected from those acts by domestic or family violence laws of Maryland.

STALKING: engaging in a course of conduct directed at a specific person that would cause a reasonable person to fear for his or her safety or the safety of others, or suffer substantial emotional distress.

RETALIATION: intimidating, threatening, coercing, or discriminating against any individual for the purpose of interfering with any right or privilege secured by law or ACM policy or because an individual has made a report, assisted, provided information, or participated in any manner with an inquiry, investigation, hearing, or other proceeding related to this policy. Retaliation includes retaliatory harassment.

AMNESTY: Complainants and witnesses shall not be subject to disciplinary action for drug/alcohol violations IF (a) violation occurred during/near time of assault, (b) assault report/participation is in good faith, and (c) violation was "not an act that was reasonably likely to place the health or safety of another individual at risk."

From Maryland General Assembly HB571 / passed House and Senate, approved by Governor Hogan on May 12, 2015

---

Allegany College of Maryland prohibits sexual misconduct and sex discrimination by or against all students, employees, and campus guests. If you have any questions or concerns or if you need to make a complaint, contact ACM's Title IX Coordinator, Dr. Renee Conner in CC-152, by email at [rconner@allegany.edu](mailto:rconner@allegany.edu), or by phone at (301) 784-5206. For detailed information about policy, procedures, and prevention education, see [www.allegany.edu/titleIX](http://www.allegany.edu/titleIX).

---

### **How can you help?**

Participate in all the education and opportunities; be informal; talk to your classmates and friends; discourage bad behavior; intervene if you see something happening – anywhere; and help us create a campus climate where sexual misconduct and sex discrimination never happens.

## **10. Clery Act and Reporting Requirements**

**NOTE: FEDERAL REGULATIONS WERE IN THE PROCESS OF BEING UPDATED AT THE TIME OF PUBLICATION, SO SOME CAMPUS PROCEDURES MAY CHANGE DURING THE 2015-2016 YEAR; YOU MAY CONTACT THE OFFICE OF STUDENT & LEGAL AFFAIRS LOCATED IN ROOM 152 OF THE COLLEGE CENTER FOR THE MOST CURRENT INFORMATION.**

The Crime Awareness and Campus Security Act, enacted by Congress in 1990 and commonly known as the *Clery Act*, requires Allegany College of Maryland to disclose its policies for reporting crime, its security of and access to campus facilities, and its campus law enforcement – if any. At this time, Allegany College of Maryland does not have its own law enforcement; criminal investigations are referred to local law enforcement agencies. (See pages 19 and 86.) The Cumberland campus has one designated security officer, and Willowbrook Woods has 24-hour security at the entrance gate. Students, faculty, staff, and visitors are asked to report any crime to both local law enforcement and campus security. Additionally, the *Clery Act* requires certain faculty and staff (including security and persons with significant responsibility for student and campus activities) to report criminal acts to whomever is responsible for compiling crime data on campus; at Allegany College of Maryland, the Dean of Student & Legal Affairs has this responsibility. Reports should be made immediately; if not, then such reports should be made as soon after the crime as possible. All reported crimes (and Code of Student Conduct violations) shall be recorded. Campus security is required to maintain a daily crime log that is open to public inspection during business hours. Each year, the College submits a crime report to the U.S. Department of Education; this report is available in the Dean of Student & Legal Affairs' office.

## **11. Clery Act and Timely Warnings**

**NOTE: FEDERAL REGULATIONS WERE IN THE PROCESS OF BEING UPDATED AT THE TIME OF PUBLICATION, SO SOME CAMPUS PROCEDURES MAY CHANGE DURING THE 2015-2016 YEAR; YOU MAY CONTACT THE OFFICE OF STUDENT & LEGAL AFFAIRS LOCATED IN ROOM 152 OF THE COLLEGE CENTER FOR THE MOST CURRENT INFORMATION.**

Allegany College of Maryland will timely notify the campus community of any crime that represents an ongoing threat to the safety of students or employees. The Dean of Student & Legal Affairs, in consultation with campus security, law enforcement, and/or other officials, determines if and when a "timely warning" will be issued. This decision will be made on a case-by-case basis in light of circumstances; factors to consider include the nature of the crime, the continuing danger to the community, and the possible risk of compromising law enforcement efforts. The warning shall be intended to reach the entire campus community as soon as possible after the threat becomes known. The warning shall be issued by the following means: e-SAFE, allusers email, posted notices, telephone calls using the College's Emergency Management Plan Daytime Communication Tree, and/or the local media as appropriate.

## **12. Student Discipline**

For information regarding college rules and student discipline, please see Section Eight of this Handbook.

## **13. Cooperation with Law Enforcement Officials**

Allegany College of Maryland will fully cooperate with any law enforcement official called onto any campus by College officials or by students with the support of College officials. This cooperation may include the release of student records in accordance with the FERPA exception for emergencies; the College regards necessary intervention by law enforcement officials when there has been a reported crime to constitute an emergency for 24 hours after the report is made. Emergencies notwithstanding, the College will fully cooperate with law enforcement officials' requests for information that do not violate FERPA and with any properly issued court summons or subpoena.

## **C. Student Photo Identification (ID) Cards**

Each credit student is strongly encouraged to obtain a College photo ID.

In some instances, students may be required to show a photo identification card to obtain services at the various campuses of the College. For access to student activities, sporting events, etc., a College photo ID card will be required. As a way to accommodate students by providing a photo ID for College services and as a means to obtain discounts as a student in the community, photo IDs are made available to all credit students at each of the three campuses at the beginning of both the Fall and Spring Semesters.

Photo IDs are taken in Student Life room CC-40 (College Center Building) on the Cumberland Campus. Signs are posted prior to the start of each semester informing students when and where photo IDs will be created on the PA campuses.

The first ID card is free. The card should last your entire time at ACM; you simply show your course schedule to obtain an updated sticker each year you attend. If you lose your card, there is a modest fee to replace it.

Willowbrook Woods residents are required to carry their ID cards at all times.

## **D. Residency**

"Residency" is a legal designation that dictates the tuition that shall be charged to an individual credit student. Residency shall be designated for each full time, part time, and dually enrolled student. Each Allegany College of Maryland student shall have one residency classification. Allegany College of Maryland shall classify each incoming student as in-county, out-of-county, or out-of state for tuition purposes and shall create a process whereby the student may request a change in residency classification or appeal a current classification. This classification and process shall fully comply with the Annotated Code of Maryland and COMAR (including terms and definitions where applicable). Students who are under the age of eighteen years or who are financially dependent upon another person shall be classified in accordance with the residency of the parent, legal guardian, or person upon whom s/he is financially dependent. This policy applies to all Allegany College of Maryland students regardless of which campus or instruction site the student primarily attends.

A student's residency shall be classified upon enrollment at Allegany College of Maryland by the Office of Admission & Registration; this classification shall be determined using information provided by the student on his/her admissions application. This classification upon enrollment creates a rebuttable presumption, and the classification remains in effect as long as the student remains enrolled at the College unless/until the student's domicile changes. If the student disagrees with the classification or if the student's domicile changes, the student may petition for a change in residency and has the burden of showing by clear and convincing evidence that the classification is inaccurate. Petitions to change the residency classification shall be made to the Office of Student & Legal Affairs and must be submitted before the end of the semester for which the change is requested; the student shall be required to submit the necessary documentation with the petition to change residency.



To be eligible for a change in residency, the student must satisfy the following criteria:

- 1.) That the student's domicile or the domicile of the person upon whom the student is financially dependent is located in the locality being claimed; and
- 2.) That the student or the person upon whom the student is financially dependent has maintained this domicile for three months prior to the start of the semester for which the change is requested; unless
- 3.) The student or the person upon whom the student is financially dependent qualifies for an exception or special provision.

After reviewing all the information and any documents provided by the student, the Dean of Student & Legal Affairs shall determine whether the residency criteria being requested has been met; the decision shall be made in writing and communicated to the student in person, in writing, or electronically. Any student who wishes to appeal this decision may petition the Student Services Appeal Committee via existing committee procedures; the committee's decision is final.

Any student who provides incomplete, false, and/or misleading information related to residency may have his/her residency classification reverted to its original classification and may be subject to disciplinary action pursuant to the Code of Student Conduct. If a reduced tuition rate was obtained as a result of the incomplete, false, and/or misleading information provided, the College reserves the right to retroactively adjust the correct tuition rate for each semester affected.

The Offices of Admissions & Registration and Student & Legal Affairs shall create procedures to implement this policy as it applies to their specific responsibilities. The procedures must be consistent, and all residency determinations must be documented and stored for no less than five years.

Students are required to notify the College of any address change.

The definitions noted below apply to this policy.

#### **DEFINITIONS**

DOMICILE is a student's permanent place of abode, where physical presence and possessions are maintained with the intention of remaining indefinitely, or the permanent place of abode of any person or persons contributing more than 1/2 of the student's financial support during the most recently completed year. (This definition is derived from COMAR.)

Requirements for domicile to be established:

- a. The student\* has made the new place of abode his/her permanent home;
- b. The student\* has abandoned his/her former home state/county;
- c. The student\* intends to reside in the new place of abode indefinitely; and
- d. The student\* intends to reside in the new place of abode for a purpose other than attending Allegany College of Maryland.

\*or the person or persons contributing more than 1/2 of the student's financial support during the most recently completed calendar year.

FINANCIALLY DEPENDENT means another person provided 51% or more of the student's financial support and/or claimed the student on the most recent year's tax return.

COUNTY means a political subdivision of the State that supports a community college and the total of all counties that support a regional community college under Annotated Code of Maryland Education Article 16-302. (This definition is derived from COMAR.) (Allegany College of Maryland is not a designated regional community college.)

COUNTY RESIDENT means a student who has maintained a domicile in the county or region served by the college for at least 3 months before the date of enrollment at a college. (This definition is derived from COMAR.)

## **Section One: General Information**

MARYLAND RESIDENT means a student who has maintained a domicile in Maryland for at least 3 months before the date of enrollment at a college. (This definition is derived from COMAR.)

Special Provisions to qualify for Maryland residency unless the designation is changed by law or state regulation:

- Active duty military personnel and their dependents where the active duty member is stationed in Maryland, resides in Maryland, or is domiciled in Maryland;
- A dependent of an active military member who remains continuously enrolled after the active duty member no longer qualifies.
- Honorably discharged military veterans and their dependents within four years of the veteran's discharge and where the veteran can document (1) evidence of attending a public or private secondary school in Maryland for the last three years and graduated from a public or private secondary school in Maryland or received a high school equivalence diploma in Maryland and (2) resides or is domiciled in Maryland;
- National Guard member who is a member of the Maryland National Guard and who serves to provide a Critical Military Occupational Skill or is a member of the Air Force Critical Specialty Code.
- Military veterans in accordance with federal law and regulations;
- A student enrolled in a program designated by the Maryland Commission on Higher Education as a health manpower shortage or statewide designated program;
- A student from outside the State who enrolls as part of a reciprocity agreement negotiated between Maryland and another state;
- A student from outside the State who enrolls in an education program leading to licensure in nursing and who furnishes a surety bond or guaranteed promissory note in accordance with COMAR rules;
- A student who resides in Maryland but does not otherwise meet in-state residency requirements and is a full-time public school teacher employed by Allegany County Board of Education for less than one year and the course/program is required by the state or Allegany County to maintain the teacher's position with the Board of Education; and
- A student who has moved to Maryland as an employee or family member of an employee as part of Base Realignment and Closure process.
- A student who is qualified under the Maryland Dream Act.
- Any other designation pursuant to federal or Maryland law or regulation.

ENROLLMENT means a student has processed the registration forms and the [course] schedule is either provided to the student or made available to him/her online. (This definition is derived from the College's FERPA policy; however, the Office of Admissions & Registration may classify an applicant's residency upon receipt of the admissions application, and this classification becomes the formal designation when a course schedule is received.)

OUT-OF-STATE RESIDENTS shall be any other person for residency purposes. Students whose domicile is located anywhere except Maryland shall have their residency dictated by the laws of their respective state or commonwealth unless a special provision for Maryland residency applies.

REQUIRED TERM OF RESIDENCY: three (3) consecutive months immediately prior to enrollment.

BURDEN OF PROOF: the student has the burden of proving by clear and convincing evidence that s/he satisfies the requirements for the requested residency change.

*Approved by Advisory Policy Team(s) 10/01/14 (S&LA)  
12/04/14 (AEM)  
Approved by President's Advisory Team 02/10/15  
Approved by Board of Trustees 02/23/15  
Implementation Date 07/01/15*

## **E. Student Life**

### **1. Introduction**

Student Life incorporates a broad range of social, cultural, and educational programs in an attempt to meet the needs of the diverse student population at Allegany College of Maryland. The Director of Student Life serves as a liaison between the Student Government Association and other areas of the College community including the administration, faculty, and staff members. Each year the Office of Student Life distributes funds to support the following areas: recognized clubs/organizations on campus, athletics, intramurals, child care services, scholarship programs, tutorial services, game room operations, and numerous student activities sponsored throughout the school year. Additionally, the Office of Student Life coordinates: New Student Orientation programs, Red Cross Blood Drives, Drug, Alcohol and AIDS Awareness programs, and more. All student activities sponsored by the Student Government Association, the Office of Student Life, and the Center for Diversity & Student Engagement are offered to students for free or at a reduced cost with a valid ACM student ID.

### **2. Student Government Association**

At Allegany College of Maryland, the Student Government Association (SGA) functions as the governing organization of the student body. It serves as a means of participation in College governance with the faculty and administration, and acts on behalf of all students.

In addition to serving as liaison between the student body and College administration, the SGA allocates student activity funds, coordinates campus social/educational activities, and approves new campus student organizations. The student activity program is developed according to student interest and available resources. Social life is important to the college student, and a number of informal and formal activities make up the social calendar of the College. The SGA also funds a wide variety of clubs and organizations, including many of those listed below.

Students are welcome to attend any Student Government Association meeting and may contact any SGA member with ideas for new activities. Volunteers staff student activities, such as picnics and "Stress Busters" and "willing workers" should contact any SGA member or Erin Yokum, Director of Student Life. Written suggestions and comments can be sent via campus mail to Erin Yokum. The Student Government Association meets in the Diversity Center located on the lower level of the College Center Building. Meeting dates and times will be posted on the doorway of the Student Life Office.

During the Spring semester, new members to the SGA are nominated by faculty, staff, and students. Newly-nominated members serve a one-year term of office beginning in the Fall semester. A total of 15 students may serve on the SGA in any given year. If more than 15 are nominated there would be a run-off election held during the fourth week in April. Freshmen students may be considered for appointment if there are not 15 members currently serving. They may petition the SGA be voted on by simple majority of current SGA membership. All students enrolled at Allegany College of Maryland in 6 hours of credit classes or more and maintaining at least a 2.0 cumulative grade point average are eligible to serve on Student Government Association.

Each Pennsylvania Campus has its own Student Council; contact the Student Services Office at Everett (Bedford County) or Somerset (Somerset County) for more information about the specific services, activities, and events organized at those locations.

## Section One: General Information

### 3. Student Clubs/Organizations

Below is a list of current Student Clubs/Organizations. Contact the advisor listed for more information regarding meeting times, etc.

\* = Clubs/Organizations pending submission of required club/organization paperwork to and approved by SGA.

<u>Club/Organization</u>	<u>Club Advisor</u>	<u>301-784- College Ext.</u>
STUDENT GOVERNMENT ASSOCIATION (SGA)	Erin Yokum	5205
Alpha Sigma Lambda, Kappa Theta Chapter	Melody Gaschler	5697
C2J – Criminal Justice & Criminology Club	Lisa Hoston	5172
Choir	Melody Gaschler	5697
Christian Fellowship Club	Melody Gaschler	5697
Culture Club	Sharon Yoder/Miheala Wood	5297/5301
Forestry Club	Marie Perrin-Miller/Steve Resh	5256/5309
Golf Association	Josh Leibfreid	5274
Heifer International Support Club*	David Bohnert	5303
Honors	Melody Gaschler	5697
Human Services Club	Tim Rowan	5558
Massage Club	Paula Jilanis	5191
Medical Assistant Club	Lisa Rocks	5133
Medical Laboratory Technology/Biotechnology Club	Stacey Rohrbaugh	5547
NAACP Student Club*	Lynn Bowman	5258
Neo-Beats (Creative Writing Club)	Dr. Ron Jenkins	5117
Nurse's Christian Fellowship Club	Maureen Swogger	5571
Paralegal Student Association	Brandon James Hoover	5300
Peace Studies Club	Kurt Hoffman	5113
Phi Beta Lambda	Thea Hosselrode/Ron Krug	5317/5123
Phi Theta Kappa, Omicron Pi Chapter	Melody Gaschler	5697
Physical Therapy Assistant Club	Dr. Karin Savage	5535
P.R.I.D.E.	Dr. Ron Jenkins	5117
Pure Elegance Dance Team	R. Nicole Frost	5124
Radiologic Technology Club	Cathy Kline	5560
Respiratory Therapy Club	Dr. Bill Rocks	5522
SAHDA (Student American Dental Hygienists' Association)	Jennifer Thompson	5546
Student Occupational Therapy Assistant Club	Dr. Rae Ann Smith	5536
Tutoring Club	Shirley Wilson	5331
Veteran Support Club	Dr. Jim Howell	5251
Volunteer Club	Jennie Clark	5643

NOTE: If your interest(s) are not reflected here, you could start something new and exciting.

For further information on the particulars of starting a new club or about the various programs listed above, please see Erin Yokum, Director of Student Life (College Center Room CC-160) or call 301-784-5205.

#### 4. Procedures for Recognition of Student Organizations

##### Holding an Interest Meeting

Any student with an interest/hobby/passion not reflected in the above list of student clubs/organizations is strongly encouraged to explore forming a new student group by following these steps.

First, submit a Proposed new Student Club/Organization Interest Meeting Request Form to the Director of Student Life. This form must identify at least five (5) current ACM students in good standing (not on academic probation, continued academic probation, or suspended) and the signature of an ACM faculty or staff member to serve as the proposed organization's advisor. The Director of Student Life will review the request and can authorize an interest meeting (or multiple meetings if requested on the form). Permission to hold an interest meeting does NOT give the group official recognition by the College or the SGA.

Next, the five students and the designated advisor will reserve a campus room, schedule the interest meeting, and promote the meeting to fellow students. All such meetings must be open to any interested student. See "Student Communication and Publications" below for information about how to publicize the interest meeting.

Next, at the interest meeting, the organizers explain the intended group's purpose, solicit other interested students to join, select a group name (if not already selected), and start writing a constitution & by-laws to govern the group's activities. By the conclusion of the interest meeting(s), the organizers should decide if they are prepared to apply for recognition as an ACM club/organization.

##### Applying for Recognition as an ACM Student Club/Organization

*The following is the process for becoming a Recognized Student Club/Organization by Allegany College of Maryland:*

1. Submit the Application for Recognition as a New Student Club/Organization to the Director of Student Life. The Application for Recognition as a New Student Club/Organization contains the following information:
  - a. the Name & Purpose of the Organization;
  - b. the Constitution & By-laws for the Organization, which will govern the Organization's operations;
  - c. the Officers for the Organization;
  - d. the names, student ID#s, and email addresses of at least five (5) current ACM students in good standing at the College;
  - e. the signature and contact information of the proposed faculty or staff advisor;
  - f. the names of the ACM faculty and/or staff members that should have access to the Organization's College account in WebAdvisor; and
  - g. the information regarding national, state, or local affiliations with any group or persons not connected with the College, if applicable.
2. Once received, the Director of Student Life then presents the Application to the Student Government Association for consideration. The SGA shall consider and verify the Application and may request that the petitioners appear before them to provide information and answer questions regarding the proposed organization.
3. The SGA will then vote to either approve or deny the Application. **The name of the College may not be used by the organization until the organization has been officially recognized by the College.**
4. Once approved, the Organization is then considered to be officially recognized by the College and may begin to conduct business as such. A Club Account will be created through the Finance Office, which the Organization will then use to account for any monies raised/spent by the Organization.

## Section One: General Information

5. If denied, the SGA will notify the petitioners of the reasons that the proposed Club/Organization was denied. The students that proposed the new student Club/Organization may then make any changes necessary and resubmit their Application if desired.
6. Any changes to the Club/Organization's Constitution and/or By-Laws **MUST** be approved by the SGA.

### Privileges of Official Recognition

Official recognition by the College grants the following privileges to College organizations, subject to College procedures and regulations:

- the use of College facilities rent free;
- the use of a College Account to deposit all funds for the Organization;
- the right to request a funding allocation from the SGA;
- the right to publicize events on campus (see Policy on Student Publications and Sales);
- the right to establish dues and money-raising projects within the limits of College rules and regulations.

### Maintaining Recognition

At the beginning of each Fall and Spring semester, the club/organization must submit to the Director of Student Life, a Member Update Form, which contains an updated list of club/organization members and officers, as well as the signature of the club/organization's advisor. Any changes to the club/organization's Constitution/By-Laws or outside affiliations must also be filed with the Director of Student Life.

*"Students may join any club/organization at any time during a semester; the club/organization officer(s) are responsible for maintaining an accurate roster of all members for submission at the start of the next semester."*

### Student Club/Organization Status

The College via the SGA (which bestows College recognition as detailed above) reserves the right to modify the recognition and status of a student club/organization. Any person with a concern about the operations/ activities of an ACM student club/organization shall contact the Director of Student Life, who may request a written statement detailing the concern. Any modification by SGA must be done by majority vote in an open meeting to which the club/organization officers are invited; absent a showing of misconduct, SGA decisions are final.

**Recognized/Active:** the club/organization has submitted all the paperwork and been approved by the Student Government Association. At the beginning of each Fall and Spring semester, the club/organization must submit a Member Update Form to the Director of Student Life. The Member Update Form contains a list of all the student members, a list of officers, certification that there have been no changes to the Constitution/By-Laws, and the advisor's signature.

**Probation:** the club/organization has not submitted its Member Update Form for the semester. Probation status allows the club/organization to continue functioning with rights and privileges but serves as notice that the club/organization's status is in jeopardy.

**Inactive:** the club/organization has not submitted its Member Update Form 2 semesters in a row. Rights and privileges are suspended pending submission of a Member Update Form, at which time its status is restored to Recognized/Active.

**Defunct:** the club/organization has been designated as "Inactive" 2 semesters in a row, has lost all rights and privileges, and has lost all funds accrued. (Any funds in the club/organization's account will be transferred to the SGA.) The club/organization must reapply for recognition following the same process described above.

**Suspended:** the club/organization violated ACM policy or SGA rules/procedures. Rights and privileges are suspended pending submission of an action plan addressing the violations and appropriate corrective action.

**Revoked:** the club/organization has engaged in improper fundraising/sales (see below) or has violated other ACM policies or SGA procedures while on probation or suspension. Revocation means the club/organization has lost all rights and privileges and has lost all funds accrued. (Any funds in the club/organization's account will be transferred to the SGA.) The club/organization must reapply for recognition following the same process described above.

**5. Student Communication**

Students have multiple venues for communicating with other students, faculty, and staff. Aside from face-to-face conversations, students may receive and/or issue information via WebAdvisor, the College website ( [www.allegany.edu](http://www.allegany.edu) ), email, telephone, student newsletter(s), bulletin boards, fliers/notices, Blackboard, social media, and faculty-staff mailboxes. (NOTE: with the exception of Willowbrook Woods residents, students do not have mailboxes on campus.) When engaging in verbal or written communication, all students are bound by relevant ACM policies such as the Student Communication Policy, Technology Resource Policy, First Amendment Policy, Code of Student Conduct, and other policies contained elsewhere in this Student Handbook. Federal, state, and local laws also apply (eg. copyright).

Communications related to an academic course should be managed as directed by the particular instructor and/or course syllabus. \*See Student Communication Policy (Section H).

**6. Student Publications**

ACM events, programs, activities, and publications may be promoted by a student club/organization via some/all of the tools listed above. Such materials must identify the authorized club/organization before being communicated on or off-campus. Whenever possible, ACM events, programs, activities, and publications should utilize the College's Desktop and Print Shop services.

Non-ACM events, programs, activities, and publications (eg., fliers) must be approved by the College's Advancement/Public Relations Office which has discretion to determine whether the item(s) may be promoted, consistent with other ACM policies/procedures. All such notices/fliers/posters must be stamped by that Office; generally, they are approved unless they conflict with College policy/procedure, conflict with the College's interest in promoting an educational atmosphere, contain obscenity, promote illegal activity, or endanger the safety/security of persons or property. (Exception: for handbill distribution, political signs, religious tract dissemination, and the like, refer to the First Amendment Policy and the Office of Student & Legal Affairs.)

Business solicitations and commercial sales are not permitted on campus.

Authorized notices/fliers/posters may be posted on designated bulletin boards throughout the campus; anyone wishing to post a notice on a special purpose bulletin board (eg., faculty office boards) must obtain the proper College Official's permission. notices/fliers/posters may not be hung on walls, windows, or other areas without advance permission from the proper College Official (often the Physical Plant Director). The person/entity posting notices/fliers/posters is responsible for removing the materials immediately following the event, program, or activity being promoted.

The College reserves the right to refuse any promotional endeavors. Any person who disputes a decision by the College to refuse or restrict campus communication and publication may challenge that decision via the Employee Complaint Policy, First Amendment Policy, or similar recourse.

**7. Fundraising and Sales**

Students may engage in fundraising or sales of goods/services only in the following circumstances:

- Student club/organization – with approval by the Director of Student Life
- Charitable organization / cause directly affiliated with student(s) for a specific, identified purpose – with approval by the Director of Student Life
- One-time sale/lease of personal property
- Special or unique situations – with approval by the College President

All funds raised by student clubs/organizations must be for a designated (and approved) club/organization purpose; all funds must be deposited into an approved ACM account; no funds may be dispersed for the

**Section One: General Information**

personal benefit of any club/organization member; and all financial transactions must be conducted in compliance with guidelines established by the Director of Student Life in consultation with the Finance Department.

Business solicitations and commercial sales are not permitted on campus.

NOTE: Financial Aid accounts in the campus Bookstore are for the direct educational expenses of the student whose name is on the account or for whom a Financial Aid refund is anticipated. Misappropriation of those dollars for any other purpose is not permitted.

Student clubs/organizations who violate these provisions are subject to the suspension or revocation of their privileges and/or recognition status. Any student who violates these provisions is subject to disciplinary action under the Code of Student Conduct.

**F. Athletics, Intramurals & Recreation**

Allegany College of Maryland provides facilities and organization for varsity team sports, intramural sports and recreation. The College is a member of the National Junior College Athletic Association and competes in the Maryland JUCO, which includes junior and community colleges throughout the State, and Region XX, which includes member institutions in Maryland, West Virginia, and Western Pennsylvania. Allegany College of Maryland plays a full schedule of intercollegiate competition in men’s and women’s basketball, men’s soccer, women’s softball, women’s volleyball, golf, and men’s baseball. Admission to all home games and matches is free to students with a current student identification card.

The College’s program of intramurals includes basketball, volleyball, badminton, archery, tennis, and bowling. Persons interested should contact Coach Steve Bazarnic in G-164 (Physical Education Building).

The Physical Education Building and surrounding athletic fields and courts provide a variety of opportunities for individual and group recreation. Outdoor facilities include basketball and tennis courts, jogging track, a one-mile walking/jogging trail, and fields for baseball, soccer, football, and other sports. Indoor facilities include a fully-equipped wellness center, pool, weight room, and gymnasium. With some exceptions, the outdoor facilities may be used at any time on a first-come, first-served basis. Tennis courts, the baseball diamond, and certain other athletic fields may be reserved for physical education courses, varsity teams or community athletic league use. The Athletic Department schedules facilities inside the Physical Education Building for classes, intramurals, varsity team and community use each semester. The schedule includes times for recreational use on an informal basis by credit students of such facilities as the pool, gymnasium, and weight room. These schedules are available in the Athletic Director’s Office, G-164.

**Staff Contacts**

<b><u>Staff/Coach</u></b>	<b><u>Position/Team</u></b>	<b><u>Phone</u></b>
Steve Bazarnic	Director of Health, PE, Athletics	301-784-5264
April Higson	Administrative Assistant	301-784-5265
Diana Folk	Women’s Volleyball	301-784-5529
Rick Zimmerman	Men’s Soccer	301-784-5265
Mike Baker	Men’s Basketball	301-784-5266
TBA	Women’s Basketball	301-784-5265
Chuck Eberly	Softball	301-784-5265
Steve Bazarnic	Baseball	301-784-5264
Josh Leibfreid	Men’s Golf	301-784-5274



**1. Eligibility Rules of NJCAA Intercollegiate Athletics (not inclusive)**

- a. A student must be making satisfactory progress within an approved college program or course as listed in the College Catalog. (Developmental courses count toward satisfactory progress.)
- b. Students must maintain 12 hours during each term of athletic participation.
- c. To be eligible the second semester of participation, a student must have passed at least 12 hours with a 2.00 G.P.A. or higher.
- d. Prior to a second season of participation, a student must have passed and accumulated 24 hours with a 2.00 G.P.A. or higher.
- e. After the third semester of the sophomore year, a student must maintain either a 2.00 G.P.A. on 12 hours the third semester or accumulated a 2.00 G.P.A. on 36 hours.
- f. Eligibility for a former Allegany College of Maryland student or a transfer student is determined on the basis of previous academic record.
- g. A student may participate in athletics for two seasons.
- h. An annual medical examination by a Physician is required.

(Team managers are exempt from the above requirements.)

**2. Title IX of the Education Amendments of 1972**

Title IX of the Education Amendments of 1972 protects people from discrimination based on sex in education programs or activities which receive Federal financial assistance. Title IX states that:

“No person in the United States shall, on the bases of sex, be excluded from participation in, be denied the benefits of, or be subjected to discrimination under any program or activity receiving Federal financial assistance.”

The United States Department of Education maintains an Office for Civil Rights who is responsible for enforcing Title IX.

Allegany College of Maryland’s Title IX representative is Dr. Renee Conner, Dean of Student & Legal Affairs. (See pages 21, 87, and 91 for details.)

**G. First Amendment Policy**

**NOTE: THIS POLICY IS UNDERGOING REVIEW AND REVISION DURING THE 2015-2016 ACADEMIC YEAR. IF/WHEN THE POLICY IS CHANGED, STUDENTS WILL BE PROVIDED WITH UPDATED INFORMATION. YOU MAY CONTACT THE OFFICE OF STUDENT & LEGAL AFFAIRS, LOCATED IN ROOM 152 OF THE COLLEGE CENTER FOR THE MOST CURRENT INFORMATION.**

Allegany College of Maryland honors the United States Constitution and recognizes its responsibility as a public institution to promote freedom of speech, religion, and association within the context of its educational mission and without preferential treatment. In addition to its rental facilities available for large group meetings and theatrical productions, the College has designated locations and procedures for any person/organization permissibly and lawfully on our campuses\* to distribute pamphlets or other literature, campaign for public office, picket/protest, demonstrate, or engage in similar activity free of charge. The College is not required to provide any equipment, materials, or personnel in support of these activities and assumes no liability for the actions of any person participating in or responding to the activities. Person(s)/ organization(s) shall submit a written request at least one business day in advance to the Dean of Student & Legal Affairs (or his/her designee).

\*This policy does not apply to property owned and/or managed by any non-ACM entity.

Such requests shall be granted with the following exceptions:

- No such activity is permitted in academic buildings, classrooms, and/or libraries. (On campuses where all indoor common areas are located within academic buildings, the activity will be permitted in a designated location which minimizes instructional interference.)
- Activity participants may not disrupt educational and/or administrative operations. Excessive noise is not permitted; noise will be considered excessive if it interferes with the ability of students, faculty, or staff to listen, learn, or conduct business.
- The activity may not endanger the safety or health of participants, other visitors, students, faculty, or staff.
- No other person may be compelled to participate.
- The activity may not interfere with the free flow of pedestrian or vehicular traffic.
- College property may not be defaced or damaged; banners, signs, and the like may not be affixed or attached to any College property including buildings, utility poles, existing signs, landscape walls, etc.
- All materials used must be removed at the conclusion of the activity.
- No commercial (or for-profit) sales may be conducted during the activity.
- Participants' conduct shall be consistent with the standards expected of students as outlined in the Code of Student Conduct.
- Any person/organization who engages in such activity without obtaining the College's consent may be required to cease the activity and/or exit the campus.
- No such activity shall be identified as representing an official position of the College without approval by the President and/or the Board of Trustees. (Official College entities such as clubs and committees, however, may identify themselves as being affiliated with the College.)
- Violations of these exceptions, behavioral standards, and/or laws will result in the College's revocation of its consent, and the person/organization will be required to cease its activity. Students who violate the Code of Student Conduct will be subject to disciplinary action.

Nothing in this policy shall be construed to limit or infringe on academic freedom as defined by the College. Likewise, nothing in this policy shall be construed to limit or silence the expression of an individual's personal opinion/beliefs in casual conversation, in the classroom, in assignments, in chartered student organizations, in College committees, in private actions that are not intended for public viewing/consumption, in attire, with jewelry, or other symbolic means so long as the expression does not otherwise violate the Code of Student Conduct, laws, and/or course syllabi.

Approved by Board of Trustees 6/18/07

## **H. Student Communication Policy**

### **Background**

Allegany College of Maryland must have efficient and timely methods of communicating with students. The advancement of technology facilitates communication while simultaneously saving money. These advances permit information to be shared quickly and easily for the benefit of students and the College generally; the College is committed to promoting effective communication campus-wide.

Allegany College of Maryland recognizes importance, frequency, and ease of students' communication with fellow students, College officials, and members of the public. Allegany College of Maryland also recognizes the widespread use of the internet and electronic devices to interact with other people through text, images, and sound. While these media have numerous positive benefits for students, technology carries risks such as:

- **interference with orderly academic endeavors,**
- inappropriate disclosure of confidential information,
- inappropriate disclosure of personal information and/or photographs,
- inappropriate and/or unauthorized publication(s),
- dilution of professional, academic relationships,

- damage to the College's reputation in the community,
- damage to personal relationships,
- violations of the Code of Student Conduct,
- violations of local, state, and federal laws such as copyright or trademark infringement,
- civil liability for torts such as defamation,
- violations of website rules / terms of service, and
- jeopardizing future employment.

#### **POLICY**

Whenever possible, Allegany College of Maryland will communicate with students electronically. Examples include email, E-safe, college website, other internet presence, and student portal; this policy shall apply to new technological methods of communication as they are developed and adopted. The College will provide the necessary infrastructure for appropriate tools. (See Technology Resources Policy for details.) Such methods of communication shall constitute official communication by the College and may replace paper communication wherever paper communication had previously been required and/or used.

- \*\* All College employees are strongly encouraged to use electronic means to communicate with students.
- \*\* All students are required to monitor their College electronic communication tools regularly and frequently; it is the students' responsibility to read all communications and to respond as necessary.

As members of the College and the larger community, students are expected to communicate with others using the means and manner consistent with the standards of an institution of higher education; Allegany College of Maryland is a place of learning, and activity which inhibits or interferes with learning or other College functions will not be permitted.

Students shall not use any means of communication to abuse, harass, threaten, bully, or otherwise harm any person. (See Code of Student Conduct for details.)

**Students shall not use any means of communication to disrupt instruction, learning, or other College functions; likewise, priority shall be given to uses of electronic communications and/or technology which promote academics.**

The personal use of the internet and/or electronic devices by students **outside the classroom or other learning sites** shall not be infringed; such **personal** use shall not constitute official College communication, and the College is not responsible for the content of students' personal communications. However, the College reserves the right to act upon personal student communications when such communication has a negative impact upon any official function of the College including instruction, health, safety, and public relations. Nothing in this policy shall be construed to restrict any person's right to avail themselves of civil remedies.

Students shall not use the College's logo(s), trademarks, letterhead, or other intellectual property without prior consent from the authorized College official. Students shall not create an internet presence or a publication that purports to be official or authorized by the College without prior consent from the authorized College official.

Related Allegany College of Maryland policies maintain their full force and purpose (eg., Technology Use Policy, First Amendment Policy, FERPA, HIPAA, career program curricula/handbooks, Code of Student Conduct, etc.).

### **I. Student Housing**

Allegany College of Maryland offers student housing for 236 residents in a garden-style apartment complex organized into 5 buildings of 3 floors; each floor has 4 apartments housing 4 full-time student residents. (Residents must carry a minimum of 12 credits/equivalent to live in housing.) Apartments have common living rooms and kitchens, 4 bedrooms, 2 bathrooms, balcony, and storage closets. Each living room and bedroom has phone and cable outlets. Willowbrook Woods has a Clubhouse with a large screen TV, comfy sofas,

## **Section One: General Information**

tables/chairs, vending machines, and laundry facilities. There is also a patio and large courtyard. Only residents, housing staff, and eligible guests are permitted to enter Willowbrook Woods; all persons entering housing must be approved by a Security Guard at the gatehouse, which is manned 24 hours when the College is open. (Willowbrook Woods is closed when the College is closed.) All guests must sign in and out, display a guest badge at all times, must be accompanied by their hosts at all times, must know and follow housing rules such as quiet hours and permitted length of visits. Willowbrook Woods is a dry campus, meaning no alcoholic beverages or containers are permitted by anyone, regardless of age.

### **Mission Statement**

The Office of Residence Life strives to support the mission of the College in our commitment to the holistic education and personal development of students, through the provision of a safe, comfortable, secure, just, caring and mutually respectful learning community, which fosters inclusive education outside the formal classroom as well as a sense of community, citizenship, responsibility and appreciation of diversity.

### **Goals**

1. To promote an atmosphere of study, research and reflection.
2. To foster self-reliance and individuality.
3. To provide a staff, which is respectful, courteous, equitable, trustworthy and a resource for students both personally and academically.
4. To challenge students to promote appropriate behavior and safety precautions for themselves and others.
5. To foster ownership of both the physical and psychological community within housing and the campus.
6. To provide meaningful leadership opportunities for students.
7. To challenge each student to be a positive contributing member of the community.
8. To promote the acceptance of all individuals through the acknowledgement and celebration of differences.

### **J. Off-Campus Housing**

For students looking for living accommodations off campus, the Office of Student & Legal Affairs maintains a list of off-campus housing options. This list is a collection of off-campus, private housing from area landlords. The College maintains the list for convenience purposes and the College assumes no responsibility for the condition of housing listed and does not make inspections. The College is not involved in any way with the contractual relationship between the student and the landlord/manager. Upon request, the list is mailed (or emailed) to prospective students and/or can be picked up at the office. Students are also encouraged to check with the local newspaper and realtors for additional listings. For further information on off-campus housing, please contact the Student & Legal Affairs' office at 301-784-5206.

### **K. Campus Kids Child Care Center**

Allegany College of Maryland has a Child Care Center which is available to students attending the Cumberland Campus. Applications are available from the manager of the Child Care Center or the Office of Student & Legal Affairs (Room 152 in the College Center Building). The Child Care Center is located on Old Willowbrook Road. The Center is open Monday through Friday during the Fall, Spring, and Summer semesters. The Center is operated under the regulations of the Maryland Department of Health and Mental Hygiene and the Allegany County Health Department. The Center is for College students and employees during class hours. Student study time coverage may be arranged if space allows. Children must be between the ages of three and twelve, must be toilet trained, and must be up to date on immunization vaccines. In addition to required documentation such as vaccinations, all parents are asked to complete an expectations survey when registering their child(ren). Enrollment paperwork must be submitted and on file at the center before a child may be left at the center.

Fees for child care services are as follows:

The student fee is \$1.75 per hour per child.

The staff fee is \$2.25 per hour per child.

The general public's rate is \$2.50 per hour per child.

Further information on the Child Care Center may be obtained by calling the Center at 301-784-5236.

## **L. Center for Diversity & Student Engagement**

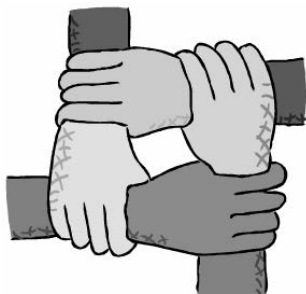

The purpose of the College's Center for Diversity & Student Engagement (i.e., Diversity Center) is to create and maintain a campus learning environment where all people feel welcome and safe and where students can find a place to connect with each other, faculty/staff, and the institution itself. The Diversity Center organizes and supports events, programs, activities, groups, discussions, and personal guidance that further the College's commitment to diversity as stated by the Diversity Task Force in FY04 and FY05:

**Diversity is "otherness" or those human qualities that are different from our own, [are] outside the groups to which we belong, yet are present in other individuals or groups.**

If you are planning an event or program and want the Diversity Center to help, contact the Office of Student Life. The Diversity Center is located in the College Center, Room 150.

The Diversity Center is perfect for . . . . .

- Education
- Awareness
- Meetings
- Support
- Event Planning
- Camaraderie
- Quiet Refuge
- Sharing experiences
- International students
- ESL students
- Special Needs students
- GLBT students
- Religious/spiritual students who don't have a local denomination
- Anyone who embraces diversity in all its forms and/or who is open to learning about people different from yourself.

## **M. Calendar of Events**

A calendar of events is created and publicized on the calendar on the College's website under ACM Events. Each month a calendar for that month is posted in the lit display case near the Hazen Art Gallery in the College Center. The display calendar highlights information of interest for the students. Items may be included from student clubs/organizations with prior approval of the club's advisor. Students are encouraged to use the online calendar to plan their activities – recreational, sporting, and educational.

## **N. Special Needs Students**

Allegany College of Maryland is committed to providing a complete educational experience to all registered students – regardless of any student's unique challenges and/or limitations. Any student who has a special need(s) in instruction should see Section Five of this Student Handbook for information on the assistance available. Additionally, any student who requires accommodation by the College in non-instructional areas such as student housing, activities, judicial matters, and the like must contact the Disability Services Coordinator in H-54 and provide the appropriate documentation before any accommodation can be made. We look forward to working with you and want to help you succeed!

## **O. Voter Registration**

Allegany College of Maryland supports full civic engagement by its students. Staff members in the [credit] Admissions/Registration Office and the Continuing Education Registration Office can supply the voter registration form and help any person register to vote for the first time or change his/her voter registration. It is easy and free!

## **P. Using Public Transportation**

As a student at Allegany College of Maryland who does not have your own vehicle or use of a vehicle sometimes, you may use public transportation to get to/from campus. Please use this resource to help you manage your transportation needs as affordably and peacefully as possible.

Allegany County Transit offers Allegany College of Maryland students a Semester Pass with unlimited rides on the fixed bus route for \$180.00 per semester. Passes can be purchased by mail, in person at the Transit office, or online. For more information about bus routes, passes, hours of operations, and more, contact Allegany County Transit at (301) 722-6360 or visit their website [www.gov.allconet.org/act](http://www.gov.allconet.org/act)

### **Bus / Allegany County Transit**

- Information: <http://www.gov.allconet.org/ACT/>
- The bus stops at “the circle” by the flagpoles outside Humanities
- Bus schedules are posted on bulletin boards on campus and can be found on their website
- Be on time for the bus you need; drivers cannot wait for you.
- Have your fare ready. You need exact change
- **It costs \$2 (one way) to ride the bus.**
  - Frostburg State University students pay their fares via a fee through the university, so they simply show their FSU ID to board.
- Board the bus one at a time. The driver needs to verify that each passenger has paid the fare.
- Not paying your fare is stealing!
- You can purchase a bus pass in the ACM Bookstore.
- You must wear a seatbelt – ACT regulations.
- You must be able to hold/secure all property/packages/parcels.
- Eating, drinking, and smoking/tobacco use are not permitted on the bus.
- Do not distract the driver or interfere with the bus’ safe operation.
- Be courteous at all times and follow directions.
- If you do not follow the rules, you will not be allowed to ride the bus. Some violations could be reported to ACM and result in disciplinary action.

### **Taxis / Crown, Frostburg, Queen City, Yellow Cab**

- Only call for a taxi if you need one; don’t call a cab and then decide to get another ride. It costs gas for them to come to you!
- Find out how much your total fare will be or get an estimate if possible.
- If sharing a taxi, agree in advance how much each passenger will pay; then be sure to pay your fair share.
- Not paying your fare is stealing!
- Do not distract the driver or interfere with the taxi’s safe operation.
- Be courteous at all times and follow directions.
- Violations could be reported to ACM and result in disciplinary action.

## **II. Library**

The Donald L. Alexander Library has a wide range of services to assist you with your class work as well as your personal interests. The Donald L. Alexander Library staff hopes that you will explore all of these services, and, if you need assistance, please ask! They are looking forward to meeting you. If you have a special need that they should be made aware of, please let them know. They will do all that they can to accommodate you!

## **A. Special Collections**

**Appalachian Collection** (the area's largest separate collection devoted to genealogy in the tri-state area, and local history)

**U.S. Government Documents Depository** (since 1974)

### **Computer, Database, and eBook Offerings**

- Online catalog
- Computers - Internet access, Microsoft Office, and laser printing capability
- Library Online Databases and Electronic Resources – visit the library home page for current listings

## **B. Library Services**

- Reference and Research assistance
- Photocopiers
- Typewriter
- AV equipment (in-house use) for slide/cassette programs, audios and videos
- Microfilm reader/printer
- Interlibrary Loan
- Small and Large Conference Rooms – for group or private study, meetings, Library instruction
- Serenity Room – for relaxation and wellness
- Sending Faxes (for a fee)

AskUsNow! Get answers from a person, not a machine. AskUsNow! is a 24/7 live online interactive chat service. It uses the expertise of librarians to provide the residents of Maryland and students of Maryland educational institutions with answers to questions, research guidance, and help navigating the Internet. Click the link on the library home page to connect.

## **C. Borrowers**

Any student may apply for a Library card. This card will permit you to borrow from our collections of approximately 67,900 books, 150 magazine titles, Federal publications, pamphlets, audio and video tapes, DVDs, and CDs.

## **D. Loan Periods**

The usual borrowing period is two weeks for books; magazines, CDs, videos and DVDs may be checked out for two days. Renewals are allowed, unless another borrower has already placed a 'hold' on the material.

## **E. Fines for Overdue and Lost Materials**

Overdue: 2-week loans for books, CDs and magazines .....	\$ .10 per day
2-day reserves .....	\$1.00 per day
DVDs & Videotapes .....	\$2.00 per day
Lost .....	Replacement Fee minimum of \$55 per book, minimum of \$100 per video and DVD, \$15 for periodicals, \$15 for Government Documents, \$20 for CDs, and \$15 for cassettes.
Processing Fee.....	\$10 per lost or damaged library material item.
Mutilated.....	\$35 mutilation fee, plus replacement price, plus processing fee.

Borrowing privileges will be suspended when a student has \$3 or more in fines or charges. Semester grades, transcripts, and diplomas will be released when all Library materials are returned and fines are paid. The use of the Library is a privilege, not a right.

**F. Cumberland Campus Library Hours**

Monday – Thursday .....8:00 a.m. – 9:00 p.m.  
Friday .....8:00 a.m. – 4:30 p.m.  
Saturday.....11:00 a.m. – 5:00 p.m.

\*Library hours change with the College schedule. For current hours, check the library home page or call (301) 784-5269.

For questions about materials you have checked out, call 301-784-5269. For other questions, call 301-784-5138.

**G. Pennsylvania Campus Library Information and Hours**

**ASK US NOW!**

AskUsNow! is a 24/7 live interactive reference service available to students. Using professional librarians in a chat interface, students of Maryland educational institutions and residents of Maryland can obtain answers to reference or research questions around the clock.

PA students, staff and faculty should link to the “AskUsNow” connection on the bottom of the ACM library page.

**Special Note for Somerset County Campus Students**

Allegany College of Maryland shares library facilities (the building, online catalog, and equipment) with the Somerset County Public Library. Students at the Somerset County Campus can request library cards from the Somerset County Public Library (to check out books and to use the Pennsylvania Power Library from home). Since we share the online catalog with the Somerset County Public Library, it is necessary to use the county library card to check out Somerset materials.

**Special Note for Bedford County Campus Students**

The Bedford County Campus Library is open when classes are in session only and therefore there are times where there is no direct library service available at the BCC Library. If students need assistance during school breaks they are encouraged to contact Andrea Sleek, Librarian for the PA Campuses at the Somerset County Campus at 814-445-9848, ext. 6118 or asleek@allegany.edu, or contact the circulation desk at the Cumberland Campus Library at ext. 5269. The library opens the first day of each school semester and closes on the last day of the semester.

**Bad Weather Policy (PA Campuses)**

If ACM closes due to bad weather conditions, students are **NOT** required to return DVDs, books or any other ACM materials and will not be charged late fees for those days ACM is closed. **However, students are required to return ACM library materials the first day ACM re-opens.** Fines will be imposed for any days ACM materials could have been returned.

**PA Library Hours:**

**Somerset County Campus**

Library hours are posted on the College library website and library door.

**Bedford County Campus**

Library hours are posted on the College library website and library door.

Additional information about the PA Campus Hours can be found at the library’s homepage.

Books, magazines and other resources located only at the main campus library are available to Pennsylvania campus students through inter-library loan. Check with the Librarians at either Pennsylvania location for more details.



## **H. Courtesy in the Library**

### **Library Policy**

1. The professional library staff in consultation with the associate support library staff develop Library operating procedures and rules for patrons that are necessary to maintain efficient Library service.
2. The students, faculty, and staff of Allegany College of Maryland are the Library's primary clientele and assistance to them will take precedence over all other users.
3. Any resident of Allegany County or the surrounding counties is welcome to use the Library as a community library patron. A community library patron is any eligible person who is not currently enrolled in Allegany College of Maryland.
4. In accordance with College policy, children under 18 years of age who are not college students must be accompanied by an adult. \*\*See below for Somerset Campus Library.
5. All library patrons are expected to be courteous and respectful to other patrons and library staff by:
  - a. Not using cell phones or other sound emitting electronic devices in the Library.  
Cell phones must be turned off or set to vibrate.
  - b. Not using tobacco products in the Library.
  - c. Studying and talking quietly.

\*\*As long as the Somerset Campus Library is housed with the Somerset County Public Library, the Somerset Campus Library will follow the age policy of the Somerset County Public Library.

### **Library Computer Use Policy**

- Priority of computer use is given to patrons for class assignments and research.
- Patrons chatting online, checking e-mail, or doing non-class activities are expected to yield the computer to students doing class assignments and research.
- The Library reserves the right to schedule computers for instruction and other purposes.
- Downloading is permitted **ONLY** to your own storage device. Patrons are not permitted to install unapproved programs on the Library computers.
- Patrons should be aware that there is **NO** guarantee of security of any information sent or received on Library computers. It may not be safe to enter passwords, credit card numbers, account numbers, social security numbers, etc. on these computers.
- Community patrons are permitted a maximum of 2 hours per day using Library computers; they may print a maximum of 20 pages per day.
- Computers will be shut down 30 minutes before closing.

### **Appropriate Use of Computers**

Allegany College of Maryland spends a considerable amount of money to provide sufficient internet bandwidth for educational purposes. The Library computers are provided for educational activities, i.e. access to the library catalog, databases, websites, and library-related links and preparation of class projects. At times, the demand for library computers exceeds the number available. Users are asked to be sensitive to the needs of others and limit computer use during times of heavy demand.

### **Examples of Inappropriate Use**

- Monopolizing computer resources, i.e., an individual using more than one computer at a time or spending an inordinate amount of time on a computer.
- Chatting online, checking e-mail, and viewing websites not related to class studies during times of heavy computer usage.
- Viewing or transmitting pornography.
- Unauthorized copying of copyright-protected materials.
- Violating federal, state, or local laws.

## **I. Conference Room Usage**

The conference rooms in the Alexander Library are for use primarily by Allegany College of Maryland students, committees, and organizations. ACM instructors may schedule the conference rooms for classes only in conjunction with a library assignment. Non-college groups and organizations may schedule the rooms for occasional meetings subject to availability. Scheduling for events lasting more than three hours is discouraged. The Director of Learning Resources has the final say in determining room usage.

The arrangement is governed by and includes the fees listed in the College's Policy on Use of College Facilities and Theatre by Off Campus Organizations and On Campus Organizations. The Library will not be held responsible for property not removed from the premises after the use of the facility. After seven days any property remaining will be disposed of at the Library's discretion.

Allegany College of Maryland strives to promote a college that enhances lives and the community through education and service. We welcome the public and service providers to our campus. All visitors are expected to conduct themselves appropriately and lawfully at all times. ACM reserves the right to deny entrance to the College or to remove persons from the College grounds who pose a safety risk to our students, faculty, staff, other visitors, or property.

## **III. Bookstore**

Students may purchase books and various other supplies from the College's Campus Bookstore. In planning a year of study, students should include the probable cost of textbooks. Depending on the courses and curriculum taken, the cost of books per semester for a full-time student should run approximately \$400.

A book list with titles and prices for Fall and Spring semesters will be available on our website approximately three weeks before classes begin.

In addition to books, etc., students may purchase clothing, stationery, and various gift items from the Bookstore.

### **A. Hours of Operation**

The Bookstore is open Monday through Friday from 8:30 a.m. to 4:30 p.m. (Summer hours are 8:00 a.m. to 4:00 p.m.) Additional evening hours are set up for the first week at the beginning of each semester and during peak registration periods. (Students should check at the Bookstore at each Campus for notification of these additional hours.)

### **B. Procedure for Buying Books**

In order to help the Bookstore personnel in identifying the correct book(s) needed for each of your classes, they need to know the course number and the instructor for each of your classes. (This information is provided on the printout of your schedule.) The Bookstore is self service, but Bookstore personnel are available at all times to help students. Books, coats, pocketbooks, etc. are to be placed in the shelf compartments as you enter the Bookstore.

### **C. Paying by Check/Credit Card**

All checks must be made payable to "Allegany College of Maryland Bookstore" for the amount of purchase only and the student's phone number should be written or printed on the face of the check along with the student's ACM ID number. Students should note there is a charge for all returned ("bad") checks.

Books may also be paid for with credit cards and check cards. We accept Visa, Mastercard, and Discover.

### **D. Purchase of Books via Financial Aid**

Students purchasing books with any type of financial aid may come directly to the Bookstore where their information will be on file. Student identification number will be required.

## IV. Information Technology

### A. Computer Labs for Students

The College supports twenty-seven computer laboratories on the Cumberland Campus and ten computer labs at the Pennsylvania Campuses. The Information Technology (IT) Department provides support for the main campus labs that are located in the following buildings: Technologies, Science, Allied Health, Humanities, and Continuing Education. In addition to the computer laboratories noted above, the Library and the Student Success Center and various academic departments have personal computers used by students as an integral part of their services and programs. Internet access is available in all computer labs as well as the Pennsylvania Campuses' computer labs.

### B. Lab Hours

The student computer lab in room T-2B will be open Monday through Friday from 8:00 a.m. to 4:00 p.m. This lab is always open for students, unlike other computer labs which are at various times reserved for classes. As the semester progresses these times will be extended to include evening and Saturday hours.

The science lab in room S-63, computer labs in the Humanities Building (rooms H-27 and H-37) and the Allied Health lab (room AH-267) vary depending on class usage. Open lab times will be posted daily in each of these labs.

Computer labs at the Pennsylvania Campuses maintain daily hours but may vary depending on class schedule. Please check the lab schedule at the specific campus.

### C. Student HelpDesk

The student HelpDesk provides assistance for students seeking help with technology related questions. The HelpDesk can help you obtain your student ID number, student username, student passwords, student email and assist with connecting to our campus wireless system. The student username and password will provide the student with access to student email, blackboard, webadvisor, and WiFi on campus.

Once a student has obtained their username and password, the most commonly used links (by students) can be found on our college homepage [www.allegany.edu](http://www.allegany.edu). These links include blackboard, webadvisor, student email, and student HelpDesk.

HelpDesk is typically open 6 days a week during the semesters. Student HelpDesk can be found in the Technologies building, room T-20.

Typical HelpDesk hours are: (can change due to staffing)

Monday 7:30am to 4:00pm

Tuesday through Friday 7:30am to 8:00pm

Saturday 10am-3pm

We can be reached by phone: 301-784-5554

We can be reached by email: [studenthelpdesk@allegany.edu](mailto:studenthelpdesk@allegany.edu)

### D. Technology Resources Policy

#### Policy Overview

Allegany College of Maryland makes every effort to provide students, faculty, and staff with the best technologies available. In this effort, Allegany College of Maryland has installed and maintains technology resources that support diverse and ever-growing learning and administrative functions. These technology resources include computer systems, information systems, telephone systems, and network systems.

## **Section One: General Information**

This policy has been constructed to advise on the acceptable uses of Allegany College of Maryland technology resources, including but not limited to, computer equipment, the Internet, electronic mail (“email”), computer labs, voice mail, computer-based information systems, and the college computer network including wireless Ethernet.

This policy also covers the subject of access to and disclosure of computer-stored information, voice mail messages and e-mail messages (created, sent, or received) by Allegany College of Maryland's employees, and the College's rights and responsibilities in providing access to and control over its property. Technology resources and their uses are governed by college policy as well as federal, state and local laws. Individuals who inappropriately or illegally use college technology services and resources may suffer all applicable college and legal penalties for such misuse.

Access to and use of the College's technology resources are privileges granted solely to Allegany College of Maryland faculty, staff, students, and those with special accounts. These privileges can be modified, limited, extended, or revoked at the discretion of the college with or without prior warning or consent.

### **Scope**

This policy and additional guidelines for using resources apply to the use of all technology resources at Allegany College of Maryland.

### **Policy**

#### **1.0 Governance of General Use**

- 1.1 All College technology resources are designed and intended for academic and administrative use. Alternate uses may be restricted or prohibited at the discretion of the college, especially when these uses conflict with or interfere with academic and administrative functions.
- 1.2 College technology resources are not to be used to create any threatening, abusive, or disruptive messages. Allegany College of Maryland does not discriminate against any individual for reason of race, sex, color, religion, national/ethnic origin, age, veteran status, condition of disability, or sexual orientation. Allegany College of Maryland also has “Principles of Conduct” for all employees; among these principles are prohibitions on immoral/unethical conduct, offensive/brutal treatment of students and colleagues, and disparagement of colleagues. Finally, the College has a Sexual Harassment policy that prohibits – among other things – conduct that has the purpose or effect of unreasonably interfering with an individual's work or academic performance or creating an intimidating, hostile, or offensive work environment. The College's computers, Internet, email, and voice mail systems may not be used to violate these standards.

#### **2.0 Access to Technology Resources**

- 2.1 An individual shall only use the technology resources assigned to him or her. This includes use of computer-based and network-based user accounts (including email mailboxes and voicemail mailboxes), assigned passwords, and computer/network identities.
- 2.2 Users may not attempt to obtain login credentials or passwords that are not specifically assigned to them. A user's attempt to disguise or otherwise obscure the identity of the credentials or resources he or she is using is prohibited. Attempts to gain unauthorized access to technology resources are prohibited.
- 2.3 All persons shall abide by the terms of all software licensing agreements and copyright laws. Unauthorized copying of copyrighted software is prohibited. The copying of site-licensed software for distribution to persons other than Allegany College of Maryland faculty, staff, and students, or the copying of site-licensed software for use at locations not covered under the terms of the license agreement is prohibited.

3.0 Deliberate Malicious Acts

- 3.1 Any deliberate act which may impact the operation of technology resources is prohibited. Such acts include, but are not limited to, tampering with computer, network, and telephone systems, launching software attacks (viruses, denial of service, or other malicious software), and tampering with or otherwise modifying College software and systems.
- 3.2 Any deliberate act which may circumvent hardware and software security systems or data protection schemes is prohibited.
- 3.3 Unauthorized attempts to uncover or exploit security loopholes are prohibited. If such a loophole is discovered, the user is required to report his or her findings to the Computer Services department.
- 3.4 Deliberate acts which are wasteful of computing/information network resources or which unfairly monopolize resources to the exclusion of others are prohibited. These acts include, but are not limited to, sending mass mailings or chain letters, creating unnecessary multiple jobs or processes, obtaining unnecessary output, or printing or creating unnecessary network traffic.

4.0 Creation and Use of Data

- 4.1 The College observes all federal, state, and local laws pertaining to the protection of user data, including those specified by FERPA and HIPAA regulations. To the best of its ability, the College maintains the privacy of stored data including, but not limited to, user-created files, log entries, and electronic communications utilizing multiple levels of security and data protection schemes.
- 4.2 The College maintains multiple levels of data backup and data loss prevention systems. At no time should a user expect that a file he or she deletes has been completely destroyed, but the College does not guarantee the ability to recover any specific file or files in the event of accidental or unwanted deletion.
- 4.3 The College maintains the right to, but does not regularly monitor voice mail or electronic mail messages. The College will, however, inspect the contents of computers, voice mail or electronic mail in the course of an investigation triggered by indications of unacceptable behavior or as necessary to locate needed information that is not more readily available by some other less intrusive means. The contents of computers, voice mail, and electronic mail, properly obtained for some legitimate business purpose, may be disclosed by Allegany College of Maryland. Allegany College of Maryland's President or his designee will grant or deny any request for access to the contents of an individual's computer, voice mail, or electronic mail prior to access being made without the individual's consent. With exception to the College's right to retrieve and read electronic mail messages, such messages should be treated as confidential and should only be accessed by intended recipients.
- 4.4 The following types of information cannot be created or stored on any College technology resource:
  - a. Information that infringes upon the rights of any other individual or group of individuals.
  - b. Information that infringes on the copyright of any other individual or group of individuals including, but not limited to, copied or "pirated" software, music, videos, et al.
  - c. Information that may injure someone else and/or lead to a lawsuit or criminal charges including, but not limited to, viruses, malware, pornographic materials, or libelous statements.
- 4.5 Any data or network traffic exiting the College is subject to the acceptable use policies of the network through which it flows (AllCoNet, etc.), as well as to the policies listed here.

## **Section One: General Information**

### 5.0 Additional Restricted Uses of College Technology Resources

- 5.1 Use of College technology resources for personal or financial gain is prohibited. The College reserves the right to offer systems and services that allow for the promotion of personal goods and services, but does not sponsor, endorse, or support said goods and services.
- 5.2 The College reserves the right to offer systems and services that allow for the promotion of charitable goods and services, and to solicit for charitable contributions, but does not sponsor, endorse, or support said goods, services, and solicitations.
- 5.3 Use of the College's technology resources to monitor another user's data communications, or to read, copy, change, or delete another user's files or software without the user's permission is prohibited.
- 5.4 Use of the College's technology resources to operate any unauthorized network server is prohibited. This includes, but is not limited to chat, file, print, web, and application servers.

### 6.0 The College's Right to Recourse

- 6.1 Access to and use of College technology resources are privileges. These privileges can be modified, limited, extended, or revoked at the discretion of the college with or without prior warning or consent.
- 6.2 Individuals who inappropriately or illegally use college technology services and resources may suffer all applicable College and legal penalties for such misuse.
- 6.3 Individuals who violate Allegany College of Maryland Technology Resources Policy may be subject to discipline, up to and including termination or dismissal.

#### **User Responsibilities**

The Computer Services department and the President should be notified about violations of laws and policies governing information use, intellectual property rights, or copyrights, as well as about potential loopholes in the security of the College's technology resources.

The user community is expected to cooperate with the College in its operation of technology resources as well as in the investigation of misuse or abuse. Existing College policies including Sexual Harassment policies, policies on Student Conduct, Academic Integrity, Facilities Use, etc. will be enforced as they relate to a violation of the *Allegany College of Maryland Technology Resources Policy*.

#### **E. Student Communication Policy**

Allegany College of Maryland has adopted a new policy that applies to all students and became effective on February 28, 2012. The Student Communication Policy requires ACM officials to communicate with students electronically (via email, college website, student portal, etc.) whenever possible and requires students to monitor their electronic communication tools (particularly email) regularly and frequently. This policy means that future, official correspondence from the College will be via email rather than postal mail and "it is the students' responsibility to read all communications and to respond as necessary." Therefore, you should make it a habit to use your [username@student.allegany.edu](mailto:username@student.allegany.edu) account on a daily basis.

The Student Communication Policy also includes some restrictions such as using College communication tools appropriately, not using personal communication devices (such as cell phones) to disrupt classes, and never engaging in cyber-bullying or other abusive/harassing behaviors.

See Section I.H above for the complete text of the policy.

Questions about the policy should be directed to the Office of Student & Legal Affairs at (301) 784-5206.

## V. Food Services

The Cafe (College Cafeteria) makes available breakfast and lunch daily, Monday through Friday. Breakfast, served from 8:00-10:00 a.m., features baked goods, hot breakfast items, cereal, fresh fruit, and a complete line of hot and cold beverages. Lunch, served from 10:00 a.m.-2:00 p.m., Monday through Friday, features hot entrées, homemade soups, salads, pizza, grilled sandwiches, pasta, and much more.

The College also offers prepaid dining plans that assure you of a meal or snack without having to carry cash. It is an excellent way to both plan and stick to your meal budget for the semester. You also get added value (more spending power) with the Gold Plan card.

Your Gold Meal Plan Card will be credited with your deposit and bonus monies. The minimum buy-in fee for this plan is \$100.00 and offers 10% bonus cash. You can keep enjoying the 10% bonus cash by recharging your card in \$100.00+ increments. Each time you purchase a meal or snack, that amount is automatically deducted from your account. Your cashier can tell you what your remaining balance is after each transaction.

Your Silver Meal Card offers the convenience of dollar to dollar spending with a minimum buy-in fee of \$25.00. This makes it easy to keep the card in your backpack and eliminates the need to carry cash. Your account works like a debit card for food. If you deposit \$25 into your account, then spend \$5 for lunch, your balance would be \$20. It's really that simple.

It's easier than maintaining a checkbook! If you lose or misplace your card, notify us immediately and we will protect your account.

Please stop by the Café and purchase the plan that works for you.

Numerous vending machines are located in the following buildings on campus; College Center, Humanities, Science, Technology, Continuing Education, Physical Education, and Allied Health. Fresh supplies of snacks, hot and cold beverages, candy, fresh fruit, yogurt, and many other items are available daily.

## VI. Information Center

The Information Center staff serves students by answering questions on current events, departmental services, campus directions, and other general college questions. Located in the center of the Continuing Education building, they are open Monday thru Friday 8:00 a.m. – 5:00 p.m. They can be reached by calling 301-784-5000 or via e-mail at [infocenter@allegany.edu](mailto:infocenter@allegany.edu). In addition, you may chat with them online through the college website, [allegany.edu](http://allegany.edu), Monday thru Friday from 11:30 a.m. – 4:30 p.m.

## VII. Inclement Weather/College Closing Policy

### **How will I know if the College closes or has a delayed opening?**

If inclement weather or an emergency forces the College to close or have a delayed opening, you may call the College directly at **301-784-5000 in Cumberland; 814-445-9848 in Somerset, or 814-652-9528 in Bedford County** for cancellations or delayed opening announcements. Another option is to log onto the College's website at [www.allegany.edu](http://www.allegany.edu). Information will also be given to area radio and television stations. In addition, ACM offers e-SAFE, a text messaging service. To sign up, please log onto our website at [www.allegany.edu/esafe](http://www.allegany.edu/esafe).

Whenever probably that a delay or cancellation is necessary, a decision will be made the evening before. Evening announcements will be transmitted at approximately 8:30 p.m. If an announcement for daytime classes cannot be made the evening prior, then announcements for daytime classes will be transmitted at approximately 5:15 a.m., and by 2:00 p.m. for classes beginning at 4:00 p.m. or later.

### **There are generally three types of announcements given to the media:**

- "Allegany College of Maryland will open at \_\_\_\_\_ (time)."
- "Allegany College of Maryland's classes scheduled to begin at or after \_\_\_\_\_ (time) are cancelled."
- "Allegany College of Maryland \_\_\_\_\_ Campus (es) is (are) closed today."

**Section One: General Information**

When classes are delayed or cancelled due to inclement weather, the media outlets listed below will be making the announcements. This list can also be found on our website at [www.allegany.edu/weather](http://www.allegany.edu/weather). Students should park their vehicles in any parking lot that has been cleared of snow/ice. Precautions need to be taken on inclement weather days including wearing appropriate shoes, and walking and driving slowly around campus.

Students are discouraged from coming onto campus when the College is closed due to inclement weather. Students who come to campus on these days do so at their own risk.

**Website:** ACM Homepage – [www.allegany.edu](http://www.allegany.edu)

**Text Message/Email: e-SAFE** – Sign up is available on our website at [www.allegany.edu/esafe](http://www.allegany.edu/esafe).

**Cumberland Campus: 301-784-5000**

WKGO	1450 AM	106.1 FM	Cumberland
WTBO		105.7 FM	Cumberland
WCBC	1270 AM	107.1 FM	Cumberland
WQZK		94.1 FM	Cumberland
WDYK - Magic		100.5 FM	Cumberland
WDZN - ZROCK		99.5 FM	Cumberland
WVMD - theWOLF		100.1/99.9 FM	Cumberland
WCMD - ESPN Radio	1230 AM		Cumberland
WKLP - ESPN Sports	1390 AM		Cumberland
WFRB	560 AM	105.3 FM	Frostburg
WLIC- WAIJ		97.1/90.3 FM	Frostburg
WMSG - WKHJ	1050 AM	104.5 FM	Oakland
WQZS		93.3 FM	Meyersdale
WHAG-TV, NBC 25		Channel 12	Hagerstown

If you are attending a Pennsylvania Campus, you'll need to call that campus directly. Announcements about the Cumberland Campus are included with any announcements about the Pennsylvania Campuses.

**Somerset County Campus 814-445-9848 (from the main campus dial ext. 6100)**

WCCL		101.7 FM	Somerset
WQZS		93.3 FM	Meyersdale
WRKW/Rocky 99		99.1 FM	Johnstown
WKYE/96 Key		96.5 FM	Johnstown
WFGI/Froggy 95		95.5 FM	Johnstown
WJHT/Hot92		92.1 FM	Johnstown
WJAC-TV		Channel 6	Johnstown
WWCP-TV		Channel 8	Johnstown

**Bedford County Campus: 814-652-9528 (from the main campus dial ext. 6200)**

WBFD - News Talk	1310 AM		Bedford
WAYC - Star	1600 AM	100.9 FM	Bedford
WBVE - B-Rock		107.5 FM	Bedford
WZSK/WSKE	1040 AM	104.3 FM	Everett
WFGY/Froggy 98		98.1 FM	Altoona
WRKY/Rocky 104.9		104.9 FM	Altoona
WWOT/Hot 100		100.1 FM	Altoona
WFBG/BIG 1290	1290 AM		Altoona
WALY		103.9 FM	Altoona
WVAM/ESPN Radio	1430 AM		Altoona
WTAJ-TV		Channel 10	Altoona
WJAC-TV		Channel 6	Johnstown



## VIII. Special Information for Students at Somerset and Bedford Campuses

\* See also PA directory in Section Eleven.

Much of the information in this Handbook pertains to students enrolled at any Allegany College of Maryland Campus. But, there are some differences. Not all of the student services are available at the Somerset County and Bedford County Campuses, but they can be accessed by contacting appropriate offices on the Cumberland Campus. Sometimes a telephone call can provide the needed information. If you plan to visit a main campus office, making an appointment in advance will help assure that the needed assistance will be available. All of the student services offices, the Library and Bookstore, and the assistance of instructional department chairmen and directors are available to Pennsylvania Campus students.

Student councils have been formed at both campuses to plan a student activities program. However, students are encouraged to attend athletic and cultural events and other student activities scheduled at the main campus. In some cases, an admission fee is charged. Students of Allegany College of Maryland’s Pennsylvania Campuses are required to pay a student services fee. This fee is used to underwrite tutoring and other student support services at Pennsylvania Campuses.

The provisions of Section Eight of this Handbook, “Code of Student Conduct,” apply to Somerset County and Bedford County Campuses students, with the exception of chartering student organizations eligible for support from student activity monies.

### Telephone Contact with the Cumberland Campus

Main Campus Telephone Number .....	301-784-5000
Local Number from the Somerset Area .....	814-445-9848
Local Number from the Everett Area .....	814-652-9528
Facsimile Device (FAX) Numbers:	
Admissions Office .....	301-784-5027
Continuing Education .....	301-784-5025
Library .....	301-784-5017
Financial Aid .....	301-784-5010

### Student Services of Pennsylvania Campuses

Support services are available to students attending the College’s Pennsylvania Campuses. Services available include transfer and career advising, placement assessment, peer tutoring, and assisting students with disabilities.

Students should call the Bedford County Campus at 814-652-9528, ext. 6224 or the Somerset County Campus at 814-445-9848, ext. 6135 for assistance.

Bedford County Technical Center: ACM students taking classes at the Bedford County Technical Center (BCTC) are expected to adhere to the policies of the BCTC.



## **SECTION TWO: REGISTRATION FOR COURSES AND ADDING/DROPPING COURSES**

### **I. Registering for Courses**

All students are expected to register for classes during registration periods listed in the College calendar. New and former students should make appointments for advising and registration in the Admissions Office. Current students may register at any time during the registration period after consulting with their academic advisor.

### **II. Adding a Course**

Courses added during the first week of classes require the signature of the instructor and academic advisor of the course. The student must complete a "Course Registration Form"\* This form must be on file before the addition of a course becomes final. No course may be added after the first week of classes except by written approval of the Academic Standards Committee.

### **III. Dropping a Course**

A student may withdraw ("drop") from one or more courses during the period indicated in the academic calendar by completing a "Course Registration Form".\* This form must be on file before the dropping of a course becomes final. A course may not be officially dropped or changed to an audit after the first day of the tenth week of the semester, except by written approval of the Academic Standards Committee.

If a student neglects to follow the official withdrawal procedure and merely ceases to attend classes, a grade of "F" may be recorded at the end of the semester. The official date of withdrawal is the date on which the completed "Course Registration Form" is filed with the Registration Office or the date of the Academic Standards Committee's action. The student is responsible for all assigned coursework up to this date.

### **IV. Repeating a Course**

A student may take and complete the same course for credit no more than three times. **Only the repeated grade will be computed in the student's grade point average.** However, the earlier grade and record shall remain listed on the student's transcript. W, R and X grades will not be used to replace grades of D, F or X earned in previous attempts.

In order for a student to receive quality points for a course for which a grade of F, P, R, W, or X was received, the student must repeat the course and earn a grade of A, B, C, or D at Allegany College of Maryland.

To receive credit for any course in which a grade of "F" was received at Allegany College of Maryland, the student must repeat and pass the course at this institution subject to the provisions of Academic Regulations section O-02 unless permission for taking the course elsewhere has been granted in advance by the Director of Admissions & Registration.

\*Available in the Registration Office (in the College Center Building).

## **V. Accessing Information Using WebAdvisor**

### **What is WebAdvisor?**

WebAdvisor is our student information system and a central component of our ERP system.

### **Access**

The stand-alone website for WebAdvisor is located at <http://webadvisor.allegany.edu> . When visiting WebAdvisor, a student should login using his ACM Username and Password.

### **Registering New Students**

New students are required to meet with an advisor to select classes. Advisors should complete the registration grid with the desired course sections. The student should be instructed to bring the grid to the Registration Office to be processed.

### **Registering Current Students**

Current students have the ability to self-register using **their** own WebAdvisor login. Although not required, current students may opt to meet with their advisors before or after the self-registration process. A student's advisor can make changes to course selections, manage Wait List entries, or assist the student through the entire registration process using **Express Registration**.

### **Express Registration**

Our ERP system offers Express Registration. This feature of WebAdvisor allows the student to build his entire course schedule in one simple step. By entering a course selection on a single form, our ERP system checks for pre-requisites and automatically registers the student for courses. If errors or pre-requisites exist, the Express Registration system provides details on how to successfully complete the registration process.

### **Wait Lists**

Our ERP system offers Wait Listing. Once a section fills, a student can select to be placed on the Wait List for the section. If a seat becomes available, the student will be notified by e-mail that a seat is open. Then the student will have two days to access WebAdvisor and add the section. If the student does not add the section within two days, the wait list entry is removed and the section is offered to the next student on the list.

### **System Maintenance**

Due to necessary system maintenance, WebAdvisor will be inaccessible Monday through Friday from 5:00 p.m. – 8:00 p.m.

## **VI. Veteran's Affairs**

Veterans, veterans' widows, and war orphans should contact the Veterans' Officer for information and assistance related to educational benefits to which they are entitled under public law. Assistance may be obtained regarding the appropriate channels through which problems unique to veterans may be approached and rectified. The Veterans' Officer is located in the Registration Office in the College Center Building and can be reached at 301-784-5203.

According to Public Law 94-502, a veteran needs to consider the following:

1. Audited Courses ("R") - These courses do not result in credit being granted toward graduation. Because no credit toward an educational objective can be earned for such a course, it is not properly part of the student's approved educational program. Subsequently, no benefits can be earned for taking audited courses.

## ***Section Two: Registration for Courses and Adding/Dropping Courses***

2. **Nonpunitive Grades** - At Allegany College of Maryland, nonpunitive grades are “W” and “X.” These grades, whether upon completion of the course or at the time of withdrawal, have the effect of excluding the course from consideration in determining progress toward fulfillment of requirements for graduation. No credit toward graduation is granted for such a grade, nor is there any effect on other graduation factors imposed by school policy, such as grade point average. Courses in which “W” and “X” grades are received are equivalent to audited courses for purposes of advancement toward graduation.
  - a. **The “W” Grade** - A “W” grade (withdrawal grade) is granted to students up until the first week after mid-term. If you receive a “W” grade (for instance, going from twelve to nine credit hours; nine to six credit hours; or to six or less credit hours), the difference has to be repaid to the V.A. depending on the amount of benefits paid. However, if there are mitigating circumstances, this policy may be waived.
  - b. **The “X” Grade** - In relation to the “X” grade, veterans no longer have the opportunity to use the “X” grade. In the event you receive an “X” grade at the end of the semester, you have to repay the difference accrued between twelve or nine credit hours, or six or less credit hours. There are also a number of mitigating circumstances that can affect the recipient of an “X” grade.
3. **Punitive (Failing) Grade** - This is a grade assigned for pursuit of a course which indicated unacceptable course work and no credit granted toward graduation for that pursuit. Although this type of grade results in no credit, it is distinguished from a nonpunitive grade by the fact that it is considered in determining overall progress toward graduation in that a penalty is exacted in a school graduation requirement, such as a grade point average. A course for which a punitive failing grade is assigned is not equivalent to an audited course because the grade is computed into a graduation requirement.
4. **Changes of Academic Status** - All Veterans must report any changes of academic status to the Veterans Affairs Coordinator located in the Registration Office.



## **SECTION THREE: STUDENT FINANCIAL AID**

### **I. Information and Policies**

Purpose - Allegany College of Maryland offers a variety of student financial aid programs. The primary objective of these programs is to extend the opportunity for a college education to all students who need assistance in meeting college expenses. All applicants for student financial aid must demonstrate financial need and academic capability.

**Financial Aid Sources** - The College participates in seven federally funded student financial aid programs:

Federal Pell Grant - gift aid, not to be repaid; full-time, part-time (6-11 credits), and less than part-time (1-5 credits) students eligible.

Federal Supplemental Educational Opportunity Grant (FSEOG) - gift aid, not to be repaid; full-time and part-time (6 to 11 credits) students eligible.

Iraq and Afghanistan Service Grant - (New starting 2011-12) gift aid, not to be repaid; full time, part-time (6 to 11 credits), and less than part-time (1 to 5 credits) students eligible. For students who are not Pell Grant eligible, but whose parent or guardian died as a result of military service in Iraq or Afghanistan after September 11, 2001; and who, at the time of the parent's or guardian's death, were less than 24 years old or were enrolled at least part-time at an institution of higher education. Award amount is determined annually by the Federal Government.

Federal Work-Study (FWS) - Part-time employment on or off campus; pay rate is \$8.50/hour; full-time or part-time (6 to 11 credits) students eligible. Students employed in the America Reads Program receive \$11.50 per hour. Funds are also available for summer; and students must complete the summer work-study application which is available in the Student Financial Aid Office or on our website.

William D. Ford Federal Direct Loan Program – Subsidized Stafford Loan – A low interest loan that enables students to borrow up to \$3,500 at the freshman level, \$4,500 at the sophomore level, and \$5,500 at the junior and senior undergraduate level, and \$8,500 for graduate study. Aggregate limits are: \$23,000 for undergraduates and \$65,500 for graduate and professional degree work. Interest rate is expected to be 4.66% for loans disbursed after July 1, 2015; however, the rate is subject to change as determined by Congress. Students must show need in order to be eligible to borrow. The Federal Government pays full interest on the loan while the student is in college; however, interest begins to accrue at the time the student graduates, withdraws, or drops below 6 credit hours. Repayment of the principal and interest begins 6 months after the student is no longer enrolled in at least 6 credits, although students can elect to make payments at any time after the loan is disbursed. Deferments are available. Students are also required to pay a 1.068% default fee on the principal amount of the loan, which is proportionately deducted from each loan disbursement. For new borrowers after July 1, 2013, there is now a limit on borrowing under this program equal to 150% of the time allowed to graduate in a program. Information on this limit is available from the Student Financial Aid Office or on the ACM Financial Aid website.

William D. Ford Federal Direct Loan Program – Unsubsidized Stafford Loan – A low interest loan that enables students who show little or no eligibility to borrow under the Subsidized Stafford Loan to borrow at those same levels plus an additional amount of \$2,000 for dependent students and \$6,000 for independent students. A student whose parents are unable to borrow under the Parent PLUS Loan program can borrow an additional \$6,000. Interest rate is expected to be a fixed rate of 4.66% for loans disbursed after July 1, 2015; however, the rate is subject to change as determined by Congress. Unsubsidized loan recipients are responsible for payment of interest during in-school, grace, and deferment periods. Students are also required to pay a 1.068% default fee on the principal amount of the loan, which is proportionately deducted from each loan disbursement.

Federal PLUS Loans (Parent Loan for Undergraduate Students) - Enables parents of dependent students to borrow funds to assist with their student's education. Parents may borrow up to the student's estimated cost of attendance minus any financial aid. Interest rate is expected to be 7.21% for loans disbursed after July 1, 2015; however the rate is subject to change as determined by the Federal Government. There may be an origination fee of up to 4.272% of the loan amount. Repayment usually begins 60 days after the loan is fully disbursed; however, parents can elect to delay repayment on the Parent PLUS Loan until 6 months after the dependent student for whom they borrowed ceases at least half time enrollment. Checks are made copayable to parent and school and disbursed to the institution.

**How to Apply** - Students must complete the Free Application for Federal Student Aid (FAFSA). Parent borrowers (PLUS) must visit [www.studentloans.gov](http://www.studentloans.gov) to complete the parent application process. Students should apply for financial aid as soon after January 1 as possible for each academic year for which they will be enrolled. Applications received by March 1 for Fall semester and November 1 for Spring semester will be given first consideration for all types of financial assistance. The FAFSA may be obtained from the Student Financial Aid Office, guidance offices at most high schools, or on the web at [www.fafsa.gov](http://www.fafsa.gov). Additional information, including the required forms, on student financial aid may be obtained by calling 301-784-5213, by visiting the Student Financial Aid Office located in the College Center Building, or on the web at [www.allegany.edu/finaid](http://www.allegany.edu/finaid).

**Satisfactory Academic Progress Policy** - Students must be making satisfactory academic progress in order to receive financial aid. S.A.P. requires a minimum GPA, successful completion of 67% of courses, and credential completion within 150% of program length. Copies of this policy may be obtained from the Student Financial Aid Office or on the ACM website at [www.allegany.edu/finaid](http://www.allegany.edu/finaid) under "Student Information." Students who fail to meet S.A.P. risk termination, so students should always consult a Financial Aid officer prior to dropping or not attending a class.

**Refund Policy for Title IV Recipients** - As required by the Higher Education Amendments of 1998, the Student Financial Aid Office will recalculate the Title IV federal financial aid eligibility for any student who officially or unofficially withdraws, drops out, or is dismissed from Allegany College of Maryland prior to completing 60% of the enrollment period.

Title IV Federal Financial Aid refers to the federal programs ACM participates in as authorized under the Higher Education Act of 1965 (as amended) and includes the following programs: Unsubsidized Federal Direct Student Loans, Subsidized Federal Direct Student Loans, Federal Direct PLUS Loans, Federal Pell Grant, Federal Supplemental Educational Opportunity Grant, and the Iraq/Afghanistan Service Grant.

A student's withdrawal date will be determined as:

- a. the date the student began the institutional withdrawal process or officially notified the institution of intent to withdraw; or
- b. the midpoint of the period for a student who leaves without notifying the institution; or
- c. the student's last date of attendance at a documented academically-related activity.

### **Section Three: Student Financial Aid**

Recalculation of federal aid is based on the percent of earned aid which is determined by one of the following:

- a. If the day the student ceased attendance occurs on or before 60% of the enrollment period, the percentage of federal aid earned is equal to the percentage of the semester that was completed.  
Example: Student attends 40% of the semester, he/she earns 40% of the aid disbursed or that could be disbursed.
- b. If the student ceases attendance after completing 60% of the enrollment period, all federal aid is considered to have been earned.

The difference between the earned aid and the total aid that was disbursed or could have been disbursed is “unearned aid.”

Unearned aid must be returned to the appropriate Title IV financial aid program. If the calculations determine that “unearned financial aid” has been credited to the student’s billing account, the institution will return those funds to the appropriate federal program. However, the student will then be responsible to the institution for any outstanding charges that remain when funds are returned.

Calculations may also show that students are now ineligible for refunds of federal grants and/or loans that they have already received.

NOTE: Students who are responsible for returning “unearned financial aid funds” must make arrangements with the Business Office for prompt repayment of the funds.

Title IV Funds must be returned in the following order as required by law:

- Unsubsidized Direct Stafford Loan (other than Plus)
- Subsidized Direct Stafford Loan
- Direct Plus Loan
- Federal Pell Grant
- Federal Supplemental Educational Opportunity Grant
- Irag/Afganistan Service Grant

NOTE: Calculation worksheets and examples are available in the Student Financial Aid Office.

**STUDENT FINANCIAL AID DISBURSEMENT PROCEDURE:** Student Financial Aid refunds from our Billing Office will be mailed to students after all tuition, fees, books, and Willowbrook Woods charges have been paid in full, meaning the first financial aid payment received by the Billing Office will pay for expenses until the account is paid in full. This means students will need to budget accordingly.

In addition, students who plan to use financial aid funds to pay for Willowbrook Woods must have a completed and verified file before July 1.

Pennsylvania Campuses: Representatives from the Student Financial Aid Office have regularly scheduled appointments at the PA Campuses. Please call the respective PA Campus to make an appointment.

#### **ALLEGANY COLLEGE OF MARYLAND STUDENT FINANCIAL AID NON-DISCRIMINATION STATEMENT**

The Student Financial Aid Office of Allegany College of Maryland offers free financial aid counseling services to all persons who request such help. All students attending the College are awarded all of the student financial aid for which they are eligible. Students have the right to cancel/decline some or all of any student financial aid award at any time. ACM’s Student Financial Aid Office does not discriminate on the basis of curriculum, race, color, creed, or national or ethnic origin, gender, religion, disability, age, veteran status, or citizenship status (except in those circumstances permitted or mandated by Federal Law) when awarding or disbursing student financial assistance.



## **SECTION FOUR: FOUNDATION SCHOLARSHIP PROGRAM**

### **I. Cumberland Campus**

The Allegany College of Maryland Foundation is a not-for-profit foundation organized and incorporated under Maryland law.

Its purpose is to receive private gifts, bequests, and donations, and to account for, manage, and help appreciate monies or property submitted to the Foundation or College. Such donations are tax deductible to the extent allowed by law.

Funds for the Foundation are distributed to encourage and promote the growth, progress, and general welfare of Allegany College of Maryland's students.

The Foundation administers a large number of scholarships donated by a variety of community organizations and individuals. Each scholarship has its own set of requirements which students must meet in order to be eligible to apply. Please note that it is the policy of the Foundation that all scholarship applicants and recipients must have a minimum grade point average of 2.0 at the time of application in order to be eligible for any of the Foundation scholarships, although some scholarships may require a higher grade point average.

A catalog listing details about scholarships which are available for the coming academic year may be obtained from the Foundation Office. The scholarship application form and directions on how to apply are also provided in this catalog, or visit our website at [www.allegany.edu/scholarships](http://www.allegany.edu/scholarships).

### **Allegany College of Maryland FOUNDATION BOARD OF DIRECTORS**

David N. Aydelotte, Sr.  
Carl O. Belt, Jr.  
John J. Felten  
Lee N. Fiedler  
Bernice A. Friedland  
Dr. Peter B. Halmos

Robert E. Heltzel  
Aaron W. Hendrickson  
J. Jeffrey Hutter  
Dr. Audie G. Klingler, President  
George W. Lapp, Jr.  
Mary Ann D. Moen

Dixie L. Pownall  
Amanda W. Ruthenberg  
Judge J. Frederick Sharer  
Robert J. Smith  
Marc E. Zanger  
Margaret H. Zembower

Cynthia S. Bambara, Ph.D.  
President, Allegany College of Maryland

David R. Jones  
Vice President of Advancement and Community Relations and Executive Director of the ACM Foundation

Sandi Stein  
Administrative Assistant

Allegany College of Maryland Foundation, Inc.  
12401 Willowbrook Road, SE • Cumberland, Maryland 21502  
301-784-5200



## **II. Somerset County Campus**

The Somerset County Campus Foundation for Allegany College of Maryland, Inc., was established as a non-profit foundation organized and incorporated under Pennsylvania law.

The purpose of the foundation is to receive private gifts, bequests, and donations and to account for, manage and help appreciate monies or property submitted to the foundation or College. Such donations are deductible.

Funds for the foundation are distributed to encourage and promote the growth, progress and general welfare of the students of Allegany College of Maryland in Somerset County, Pennsylvania.

The Foundation supports students attending the college by awarding scholarships, Early College tuition assistance, George S. Cook Education Fund student loans, and emergency book funding.

### **Somerset County Campus FOUNDATION BOARD OF DIRECTORS**

Michele Beener	Roberta Lohr	Fred Rosemeyer
Jeff Berkey, Solicitor	Nancy Merrill	Brad Smith
Sharon Clapper	Daniel Mickey	Ken Warnick
Andy Cook	Peggy Ogle	Brian Whipkey
Linda Fetterolf	Tim Resh	

Cynthia S. Bambara, Ph.D.  
President, Allegany College of Maryland

Sue Funa  
Coordinator of Community, Foundation, and Workforce Development for the Somerset County Campus

Wayne Blue  
Executive Director of Workforce Development & Training

Deb Hoover  
Director of the Somerset County Campus and Student Services

Brianna Livingston  
Coordinator of Student and Career Services/Foundation

Somerset County Campus Foundation for Allegany College of Maryland  
6022 Glades Pike, Suite 100 • Somerset, Pennsylvania 15522  
814-445-9848, ext. 6136

### **III. Bedford County Campus**

The Bedford County Regional Education Foundation of Allegany College of Maryland, Inc., was established as a non-profit foundation organized and incorporated under Pennsylvania law.

The purpose of the foundation is to receive private gifts, bequests, and donations and to account for, manage, and help appreciate monies or property submitted to the foundation or College. Such donations are deductible.

Funds for the foundation are distributed to encourage and promote the growth, progress and general welfare of the students of Allegany College of Maryland in Bedford County, Pennsylvania.

The Foundation supports students attending the college by awarding scholarships, tuition assistance, and emergency book funding.

#### **Bedford County Campus FOUNDATION BOARD OF DIRECTORS**

Lynn Ashe, Secretary	Meredith Hendershot	Ralph R. Scott, Vice Chair
Dirk Barkman	Bill Higgins	Dr. Danny Webb
Craig Cutchall	Steve Howsare	Brad Will
Dr. Thomas Cypher	Dan Koontz, Chair	Larry Williams
Garry Goss	Kirt B. Morris	
Merle Helsel, Treasurer	Dixie Paruch	

Cynthia S. Bambara, Ph.D.  
President, Allegany College of Maryland

Dr. Kurt Hoffman  
Interim Senior Vice President of Instruction and Student Affairs

David Dewitt  
Vice President of Finance and Administration

Denise Bouch  
Bedford County Campus Manager

Tina Imes  
Student Services/Foundation, Office Assistant

David R. Jones  
Vice President of Advancement and Community Relations and Executive Director of the ACM Foundation

Kim Leonard  
Chair of the Board of Trustees

Leah Pepple  
Director of PA Advancement and Community Relations

Robin Swindell  
Director of Student Services, Bedford County Campus

Bedford County Regional Education Foundation  
18 North River Lane • Everett, Pennsylvania 15537  
814-652-9528, ext. 6223



## SECTION FIVE: ACADEMIC INFORMATION

### I. Student Success Center

#### A. Placement Assessment

##### **Cumberland Campus**

As a part of the advising process and the registration procedure, all freshmen who follow one of the organized curricula must complete an academic placement assessment which consists of three sections: english, mathematics, and reading. The results of the placement assessment will not affect a student's entrance to the College, but rather will determine appropriate course levels for a more successful college experience. Students are encouraged to discuss test results with testing personnel and advisors. Placement tests are administered Monday through Friday between 9:00 a.m. and noon. To schedule an assessment, call the Testing Lab at 301-784-5554 or schedule a time electronically on the College's website under placement testing. Students who live a distance from the College, may arrange to take the assessment at a location closer to their home. Suggested sites are college or university testing offices, high school guidance counselors, military testing services, and professional testing services. Proctor information is available on the College's website. As with all testing services, students must present a photo ID.



Students with verbal or mathematics scores of 500 or higher on the SAT (21 or higher on the ACT english, reading or mathematics) are exempt from developmental english, reading or mathematics. Students are required to provide the Admissions Office with copies of SAT or ACT scores.

Students who have not completed a basic college introductory biology course (Biology 100, 101, or 109 at ACM) and wish to take an anatomy and physiology courses (Biology 121, 201, or 207) must take and have a passing score on the Anatomy and Physiology Placement Examination. Please note this test is not a part of the standard placement assessment, and students must have an active Blackboard account. New students **must** schedule three days in advance, so that an account can be created. For more information please check on our College's website under placement testing.

##### **Pennsylvania Campuses**

Placement assessments are administered Monday through Friday by appointment. Students should call 814-652-9528, ext. 6224 for Bedford County Campus testing information; or 814-445-9848, ext. 6135 for Somerset County Campus testing information.

#### B. Academic/Transfer Advising

##### **Academic Advising**

Upon acceptance to Allegany College of Maryland, each student is assigned an academic advisor. The academic advising process and the student/advisor relationship play an important part of planning a student's program of study.

Each student is required to meet with his or her academic advisor as part of the process of registering for courses. Your advisor will review course selection, answer questions you may have regarding your courses or curriculum, and assist you in making academic decisions. Your academic advisor must sign your registration form listing courses for each semester.

**Ultimately, however, it is the responsibility of the student to assure that degree requirements for particular programs are met.** Advisors can also help with information about employment prospects following completion of educational programs, interpretation of academic regulations, and availability of extra-curricular and special help programs. Students should plan to meet periodically with their academic advisors throughout the course of each semester. (For a list of instructional department heads who may assist you in the absence of your academic advisor, see pages 121-123.)

### **Transfer Advising**

Students planning to transfer to a four-year college or university should discuss course transferability with their advisors or Student Success Center staff members before or during their first semester (or the Student Services Offices at the Pennsylvania Campuses). Each college or university has a unique series of required courses. Students should plan their coursework to meet the requirements of the transfer institution. Ultimately, the student has the responsibility of knowing/determining course transferability. Additional resources are available on the College's website under "Transfer Advising."

### **C. Tutoring**

Individualized and small group assistance to supplement classroom instruction is provided through the Student Success Center in the Humanities Building. The goal of the tutoring program is to help students become independent learners. Tutoring is not intended to be long-term, but rather to help a student with a distinct problem in a particular course. Due to a limited number of available tutors, students are encouraged to apply early in the semester. If tutors are not available in the requested subjects, students are assigned to a study group and/or placed on a waiting list.

The Cumberland Campus Tutoring Program offers regularly scheduled study labs for students. The Writing Center, located in H-1, offers assistance for students writing essays for all ACM credit courses, along with help with resume's, cover letters, and applications. The Math Study Lab is housed in H-66 and offers tutorial support for mathematics classes from pre-algebra to calculus. Support is also available math concerns in the sciences. The Science Study Lab in S64 also uses available lab space in the Science Building and offers assistance with basic sciences and anatomy and physiology courses. A schedule of hours is available from the Student Success Center. Individual and group tutoring is available to all students through the Student Services Office at the Bedford County and Somerset County Campuses.

To become tutors, students must be sponsored by an instructor, demonstrate academic abilities, (3.00 GPA or higher and a "B" or higher in the course to be tutored) and be in good standing with the College and community. Non-student tutors are hired only when a sufficient number of tutors cannot be recruited from the student body. Tutors are required to complete 4.5 hours of training prior to the first tutoring session. The Cumberland Campus Tutoring Program is accredited by the College Reading and Learning Association.

Online tutoring is available in all mathematics courses, basic writing courses, introductory biology, chemistry, and physics, anatomy and physiology, economics, accounting, and computer software. Services are available from 10 a.m. to 4 a.m. (the next morning). With the exception of the economics, accounting, and software for which appointments are required, all subjects are available upon demand. To access online tutoring, any registered ACM student can visit <https://www.thinkingstorm.com/acm/>.

## **D. Testing Lab/Classroom Testing**

### **Testing Lab Guidelines**

The Testing Lab offers placement assessments for prospective students, correspondence tests, and other tests arranged by students and their instructors.

To ensure the security of tests in the Testing Lab, the following guidelines have been instituted:

- Students must sign-in and present a photographic identification before entering the Testing Lab. Students who do not have an ID may request that a faculty or staff member verify their identity.
- All cell phones, laptop computers, electronic tablets, and any other electronic equipment must be turned off and secured in Testing Lab lockers or security bags. Additionally, books, book bags, purses, and other personal items must be secured in locker or security bags.
- When a staff member observes cheating in the Testing Lab, he/she will verify the activity using digital video recording. If cheating is verified, the test will be collected and the student will be asked to leave. The instructor will be notified in writing of the observed cheating and will be offered the option to review the recording. See the College's Policy Regarding Student Cheating in this Student Handbook for more information.
- Instructors who request the Testing Lab to administer tests must complete a Test Administration Form. Specific instructions as to time limits, reason for testing, aids, or books allowed must be included. To provide greater security, instructors must provide a roster of students who will be taking the tests or indicate the students' names on the tests.
- Work/Study students and tutors employed by the Student Success Center are not allowed to handle or distribute tests. Only full or part-time college employees of the Student Success Center can administer tests.
- As stated under the College's Code of Conduct Policy on Unattended Children, no child may accompany an adult into the Testing Lab. Additionally, Student Success Center staff members will not take the responsibility for watching a child while an adult takes a test.

NOTE: Testing at the PA Campuses is administered by the Student Services Office and done by appointment only.

## **E. Career Services**

Career Advising Services in the Student Success Center (SSC) is to assist students in reaching their academic, career, and personal goals. Career Advisors help to provide encouragement and guidance to students at various stages of the career development process, to inspire them to realize their full potential, and to prepare them for the dynamics of the modern work environment.

Interest inventories are designed to assist career decision-making by assessing likes and dislikes across a wide range of potential vocations. The purpose of an interest inventory is to guide the student into further career exploration. However, results frequently pinpoint a "career cluster" (a group of related careers, such as health sciences) to focus inquiry. Interest inventories are available in the Student Success Center in the Humanities Building (H-58), 301-784-5235.

Allegany College of Maryland has partnered with CollegeCentral.com to provide students and graduates with the best Web-based tools to efficiently manage their job search of the nation's finest employers seeking entry-level talent. Students attending the Pennsylvania Campuses should contact the Student Services office for assistance in Career Advising and exploration.

The Pennsylvania Campuses Student Services offices can help you head in the right direction with your education. Our Career Development Program is designed to help our students be aware of their interests, skills and personality traits in order to pursue educational majors/careers that are well suited for them. Any student planning to transfer Allegany College of Maryland credits to another college or university needs to register for classes with our Transfer Advisor to ensure a successful transition. To contact a career advisor in Student Services Office at the Bedford County Campus call 814-652-9528, ext. 6204 and the Somerset County Campus call 814-445-9848, ext. 6131.

### **F. College Level Examination Program (CLEP)**

CLEP provides students with the opportunity to demonstrate college-level achievement through a program of exams in undergraduate college courses. Students planning to transfer CLEP credit should check with their college or university to see which tests and how many credits they accept via examination. To obtain information about CLEP or to schedule an exam, call the Student Success Center at 301-784-5554 and visit [www.clep.collegeboard.org](http://www.clep.collegeboard.org) to register for a test session.

## **II. Disability Resources**

In compliance with federal 504/ADA requirements, Allegany College of Maryland supports the belief that all “otherwise qualified” citizens should have access to higher education and that individuals should not be excluded from this pursuit solely by reason of handicap. The college is committed to the integration of students with disabilities into all areas of college life. Therefore, support services are intended to maximize the independence and participation of disabled students. Further, the College complies with applicable state and federal laws and regulations prohibiting discrimination in the admission and treatment of students.

Any student who wishes to receive accommodations must register with the Academic Disability Resources Office, providing documentation of the declared disability. Once documentation is received, the Director will establish eligibility for specific accommodations based on the student’s documented functional limitations and the essential functions. Any student who wishes to declare a disability should contact the Access and Resources Coordinator at 301-784-5234 or the Director of Academic Disability Resources at 301-784-5112, TDD 301-784-5001; or, contact [wkerns@allegany.edu](mailto:wkerns@allegany.edu), [jbracken@allegany.edu](mailto:jbracken@allegany.edu) or <http://www.allegany.edu/ssc/disabledstudentservices.shtml> to obtain information and assistance.

Updated June 15, 2015

Services available include the following: tutors; readers; assistance in locating notetakers; arrangements for special examination procedures; special placement testing services, assistance in obtaining sign language interpreters; photocopied enlargements of class materials; assistance in ordering accessible textbooks; assessment and counseling for students with learning disabilities; mobility assistance; campus accessibility tours; conversion of course syllabi and short articles into accessible text; and computer-assisted instructions. In addition, adaptive equipment provided to students with disabilities includes the following: tape recorders (standard and digital), large display calculators, an enlarged computer keyboard, magnifying glasses, and wheelchairs for campus use.

Students with disabilities should also contact their local Department of Rehabilitative Services (DORS) to discuss eligibility for support services. This office may be contacted by calling (301) 777-2119. Students in Somerset County should contact the Johnstown Regional Office (toll-free from Pennsylvania, 800-762-4223), while Bedford County students should contact the Altoona Office (from Pennsylvania, 800-442-6343). Mineral County students should call (304) 788-2313.

### III. Distance Learning

#### A. Interactive Video Courses

Allegany College of Maryland uses videoconferencing technology to offer multi-point interactive distance learning courses among the Cumberland campus, the Bedford campus, the Somerset campus, and the Gateway Center. These courses meet at regularly scheduled class times in the distance learning classrooms at each site. In the distance learning classrooms, you will see and be seen, hear and be heard in real time by class members at each participating site. Your instructor may teach from the site you attend or from one of the remote sites. For more information, contact Janet Murray at [jmurray@allegany.edu](mailto:jmurray@allegany.edu).

#### B. Web (online) Courses

Allegany College of Maryland offers about 100 web courses. Web courses do not meet regularly in the classroom; most web courses are taught using our web-based learning management system, Blackboard. In online courses, you will interact online to receive course information, to complete or submit assignments and to communicate with your instructor and classmates. Some online courses require proctored or onsite exams. For more information, contact Janet Murray at [jmurray@allegany.edu](mailto:jmurray@allegany.edu).

#### C. Blended Courses

In a blended course, you will spend time learning online part of the time and in a classroom on campus part of the time. For more information, contact Janet Murray at [jmurray@allegany.edu](mailto:jmurray@allegany.edu).

### IV. Pathways for Success (Trio/Student Support Services)

The Pathways for Success Program at Allegany College of Maryland is a TRIO Student Support Services (SSS) project funded through the U.S. Department of Education. The Pathways for Success program provides a supportive environment on campus for first-generation, income-eligible students and students with disabilities. The Pathways for Success program serves 140 eligible ACM students annually.

Please check with the Pathways for Success office for additional eligibility and participation criteria. The Pathways for Success program office is located in the Humanities Building, room H-57, on the Cumberland Campus, or you may call 301-784-5630 or go to [www.allegany.edu/pathways](http://www.allegany.edu/pathways).

#### A. Eligibility

To be eligible for Pathways for Success (TRIO/SSS), a student must:

1. Be a citizen or national of the United States OR meet residency requirements for federal student financial aid;
2. Possess a GED or high school diploma;
3. Be enrolled full-time in a credit certificate and/or associates degree program, seeking first post-secondary degree, OR be accepted for enrollment in the next academic term;
4. Have a need for academic support in order to pursue successfully a postsecondary educational program;
5. Be income-eligible, a first-generation college student (meaning neither parent has earned a Bachelor's degree or higher), OR a student with a documented disability; and
6. If applicable, successfully completed English 90 and/or Reading 90.

#### B. Program Services

To assist student participants in achieving their educational and career goals, the program offers a variety of services that include:

- Tutoring
- Academic advising
- Career advising
- Transfer advising

- Financial aid and scholarship assistance
- Peer mentoring
- Support groups
- Workshops on topics like financial literacy and study skills
- College visits to 4-year institutions
- Leadership opportunities

### **C. Enrollment Process**

To be considered for enrollment, interested students must complete an application. Once program eligibility is determined, applicants will be invited for an interview. Decisions on program admission will be based on the student's eligibility, motivation to succeed, and space available. Upon admission to the program, accepted students will be assigned to a Pathways for Success advisor to develop their individualized Student Success Plans. Additional students may be placed on a wait list for later admission.

## **V. Cheating/Plagiarism**

Definition - Cheating is defined as an act of conscious deception done in order to obtain an undeserved grade; or the aiding or abetting of deception in order to obtain an undeserved grade.

Types of Cheating:

1. dishonestly obtaining and using copies of examinations;
2. using "crib sheets" or previously prepared materials during examinations;
3. impulsive exchange of information or copying from another's paper during examinations;
4. plagiarism:
  - a. the submission, as your own work, of papers or parts of papers actually written by another;
  - b. the inclusion in your own work of a passage written by another person without giving due credit; i.e., quoting or paraphrasing without proper citation of source.
5. falsifying records and/or the forging of an instructor's signature on clinical or laboratory evaluation papers.

If cheating and/or plagiarism occurs or is believed to occur, faculty have the discretion to determine the most appropriate sanction. Students who disagree with the response of the faculty to incidents of cheating and/or plagiarism should refer to the Academic Grievance Policy found on page 83 of this Student Handbook.

## **VI. Non-Traditional Student Services**

**The Non-Traditional Student Office** (formerly Turning Point Program) provides services for non-traditional learners as they begin their journey into college. Non-traditional learners are adult students who meet **one or more of the following**:

- 24 years of age or older
- Delayed enrollment (did not enter post-secondary education the same year he/she finished high school)
- Has dependent/s (children or spouse)
- Completed a GED or other high school completion certificate
- A veteran

The following services are provided:

- Personalized advising for admissions or readmission
- Assistance with understanding academic policies, rules, and regulations
- Information on careers, childcare, financial aid, housing and other college services
- Referrals to appropriate community services and resources
- Workshops and special events
- Assistance with study skills and/or forming study groups with other adult learners

On the Cumberland Campus, the Coordinator/Advocate is located in the **Humanities Building in Room 50**. For the Somerset County Campus or Bedford County Campus please contact the Director of Student Services.



## **VII. Some Notes on Academic Success**

### **Guidelines for Students from Faculty**

#### **An Opening Note**

The following “tips” were designed for you by faculty to help you in your transition from being a high school student to being a college student. Take advantage of them and you’ll increase your chances of success in college.

And since college and the work world have much in common, many of these suggestions apply to both and help to ensure success in both.

As a college student, you are an adult. That means that you are primarily responsible for your work, behavior, and grades. You have the opportunity to establish your priorities, work independently, and assume responsibility for your life.

#### **Course Load, Study Time, and Work**

You will need to spend a minimum of two hours of study for each hour in class per week. Therefore, multiply the total number of credit hours you’re taking by two to determine the minimum amount of time to commit weekly to out of class study. Budget time well to allow time each day (including weekends) for each subject. So if you are taking 15 credits, budget a total of 45 hours for class and study time. As you can see, this is certainly a full-time job! And if you are employed, you may need to adjust the number of hours you work. Don’t forget to arrange work schedules, appointments, and child care so they do not interfere with class meetings and study time.

#### **Assignments, Preparation, and Study**

Find an atmosphere for study to enhance concentration. Many students find it helpful to study with a partner or in groups. Do assignments to learn and master the skill or objective, not just to “get it done.” Look over your class notes or relevant text material and do the assignment as soon after class as possible. Exam preparation is an on-going process, not just a cram session at the last minute.

#### **Some Specifics on Reading and Note Taking**

When taking notes in class, outline the main points and record any examples given by the instructor. Do not try to record everything said by the instructor. As soon as possible after having taken the notes, update and review them while the material is clear in your mind. Periodically update and review notes.

Do assigned reading daily. DO NOT underline anything in your textbook the first time you read the material when almost everything will look important. Instead, ask yourself what you think was important in the paragraph you just read. Then selectively underline the information that answers your question, generally no more than ten percent of the text, or—better yet—note the important information in the margin. You will find it helpful to read the “Summary” section of a chapter before you begin reading the chapter. Outlining the chapter and answering study questions at the end of the chapter also will benefit you.

#### **Attendance and Responsibility for Content Missed if Absent**

The course goes on even if you are not able to be there. If you are committed to learning, you’ll keep absences to a bare minimum. It is very difficult to catch up if you miss even one class, not to mention two or more in a row. (Missing one class in college is like missing a week or more in high school.) If you must be absent, contact a fellow classmate to obtain notes or assignments. It is solely your responsibility to catch up, not the instructor’s. Research indicates that “A” students generally miss zero or only one class per semester. Attendance is very important in any course. So is promptness.

### **Faculty and Students**

While faculty members are experts in their field, they are also fellow human beings employed to help you achieve expertise and/or professional credentials. So contact each faculty member whose courses you're taking during office hours or make an appointment to review tests/assignments, clarify information, pursue more information, or deal with problems—early in the semester.

### **Enhancing Learning**

Use available teaching aids such as computer programs, video tapes, and the college library to reinforce course content.

The library has special resources such as the video "Where There's A Will, There's an A." The College's developmental education program can help you in study skills and related matters. Your instructor or advisor may refer you to such courses. They are invaluable!

### **Gaining From the Classroom**

Come to class prepared. But participate also. Being involved in class deepens and expands your knowledge. It also makes learning easier. Try to relate the class material to your interests, everyday life, and/or current events. Faculty members aren't "mind readers," so ask questions if you don't understand material or assignments. Instructors often use a variety of teaching methods and means of evaluation to help you learn as easily and pleasantly as possible.

### **Learning From Library Research**

In a library paper, you may discuss, compare, contrast, and critically evaluate material. It is not enough simply to record, without comment, conclusions or a synthesis from the material located. You must cite sources internally (footnotes of APA or MLA format) and in a bibliography. Failure to do so is plagiarism, a kind of theft.

### **Academic Freedom**

In college, students are exposed to a variety of information, philosophies, and ideas. Some are controversial. This exposure, leading to awareness and understanding, is part of becoming an educated person. Freedom to express relevant ideas in the classroom is called "Academic Freedom" and the right to do so is protected not only by tradition but also by law.

### **Attitudes Toward Learning**

College is different from high school. You choose to attend college to learn and gain important knowledge and skills for life and career. The TV/movie image of "nerds" and "geeks" belongs to fiction. Adults are serious students, interested in broadening education and in doing quality work—attitudes needed for success in today's complicated, demanding, and technical job market.

### **An Important Footnote**

These "tips" are meant to contribute to your progress in general and to every course you take. But they are merely general guidelines and neither overrule nor limit specific directions on any syllabus.

(Since "tips" are applicable to all courses, they are general. Your course syllabus may provide more specific help. Read it carefully and review it often. It will answer many of your questions and prove to be invaluable.)

### **\*Turnitin.com**

Students may be taking classes that use services at [www.turnitin.com](http://www.turnitin.com). Students understand that papers may be subject to submission for textural similarity review for the detection of plagiarism. All submitted papers will be included as source documents in the [www.turnitin.com](http://www.turnitin.com) reference database solely for the purpose of detecting plagiarism of such papers. Use of the [www.turnitin.com](http://www.turnitin.com) service is subject to the Usage Policy posted on their website.



## **SECTION SIX: ACADEMIC REGULATIONS**

The Professional College Staff of Allegany College of Maryland has adopted the following policy regarding academic regulations:

1. An academic regulation is hereby defined to be a rule, which applies to students enrolled in the credit programs of Allegany College of Maryland, which directly affects the academic standards of the College.
2. It shall be the duty of the Academic Standards Committee to recommend to the Professional College Staff the adoption of such amendments of the regulations, as it deems necessary.
3. For purpose of organization, the regulations are classified into the following sections:

Section A:	Admission as a Degree or Certificate Candidate
Section B:	Admission as a Non-Degree Student
Section C:	Students with Advanced Standing
Section D:	Readmissions
Section E:	Academic Responsibility
Section F:	Graduation
Section G:	Honors
Section H:	Grades and Scholastic Honors
Section I:	Reporting and Recording Grades
Section J:	Quality Point Average
Section K:	Academic Probation
Section L:	Removal from Academic Probation
Section M:	Suspension for Poor Scholarship
Section N:	Student Classification
Section O:	Course Repetition
Section P:	Registration
Section Q:	Academic Load
Section R:	Withdrawal from Courses
Section S:	Instructional Programs
Section T:	Course Substitutions
Section U:	Class Attendance
Section V:	Student Records and Confidentiality
Section W:	Petition and Appeal to Waive Regulations

(When a regulation fits equally well into two classifications, it has been listed in both classifications.)

4. Any new revised academic regulations shall become effective only at the beginning of the succeeding fall semester and only after the following conditions have been fulfilled in order:
  - a. The regulation has been approved by the Academic Standards Committee; and
  - b. The regulation has been approved at a Professional College Staff Meeting.
5. In cases of urgency, the Professional College Staff may take action to supersede or augment the academic regulations without regard to paragraph (4). Such actions shall be classified as temporary regulations and shall take effect immediately and only be effective for the remainder of the academic year, unless otherwise specified.
6. It shall be the responsibility of the Academic Standards Committee to review such cases as specified in the regulations and consider cases in which the application of an academic regulation to an individual may not be in the best interest of the College and the student. The Professional College Staff may make further provision in the regulations for delegating to the Academic Standards Committee the power to set aside certain specified regulations in individual cases, after full investigation and coordination with faculty and administrative offices. As a general policy, an exception to the Academic Regulations shall be made only when (1) there are cogent and compelling reasons that an exception should be made, and (2) the consequences of the exception will contribute to the overall achievement of the objectives of the College. In the event that the Academic Standards Committee shall make an exception, it shall be reported to the full-time Professional College Staff at the year end Professional College Staff meeting for purposes of record.
7. It shall be the responsibility of each member of the Professional College Staff to see that the Academic Regulations are followed and to report any non-compliance and/or any deliberate attempt on the part of a student to evade compliance to the Senior Vice President of Instruction and Student Affairs.
8. Each student shall be held accountable for the understanding and compliance with the Academic Regulations of the College.

The following is a complete list of academic regulations as approved by the full-time Professional College Staff of Allegany College of Maryland.

### **SECTION A: ADMISSION AS A DEGREE OR CERTIFICATE CANDIDATE**

A1 An applicant for admission is required to:

- a. File a formal application for admission.
- b. Furnish certified transcripts covering all previous high school and college records. Applicants who possess an Associates or higher degree need not provide transcripts of high school grades.
- c. Be a graduate of an accredited high school or possess a GED or be admitted in accordance with the minimum requirements for degree-granting institutions as issued by the Maryland Higher Education Commission.

The College may admit to college level courses and programs individuals who present evidence, through testing or other means, of the ability to profit from the instruction. In making decisions about the potential of these individuals to complete a course or courses, or programs, the Admissions Office may consider previous formal education, equivalency of other learning by examination, and competencies gained through practical experience, maturity, or other appropriate criteria.

## **Section Six: Academic Regulations**

- d. Take the College Placement Assessment. Students who have successfully completed a college-level English composition course or a college-level algebra-based course at an accredited college/university are exempt from taking the respective portion of the assessment. Students transferring in more than 12 credits of general education courses are exempt from taking the reading portion. Students with a score of 500 or higher on the Writing, Mathematics, or Reading section of the SAT or a score of 21 or higher on the English, Mathematics, or Reading section of the ACT do not need to take the respective portion of the placement assessment if they submit an official grade report to the Admissions and Registration Office. Passing the Science Placement Assessment may be required.
- e. Some selective admission programs may have additional requirements, including but not limited to the American College Test (ACT).

### A2 Developmental Education

- a. A degree applicant with no previous college experience and whose placement assessment scores indicate a need for improvement in one or more of the developmental academic areas will be placed in required developmental courses and will be limited to 14 semester hours per semester until the deficiency is corrected.
- b. Degree candidates and early college students must score at least 50 on the reading portion of the placement assessment or 62 on the ESL Reading portion of the Placement assessments, or successfully complete Reading 90 or Reading 91 before enrolling in any course numbered 100 or higher. This regulation applies to all credit courses except those specifically listed on the 'Suggested Course Mix for Underprepared Students' list, which is reviewed and updated yearly by all academic departments and approved by the Advising Committee.

Courses included in the developmental academic area include all English (including English for Speakers of Other Languages), Reading, Biology and Mathematics courses with course numbers lower than 100.

In addition, students required to take two or three first-level courses (i.e., English 90 or 91, Math 83, 90, or 91, Reading 90 or 91) must complete one of the following student development sequences concurrently with the developmental courses or prior to enrolling in the developmental courses:

- Complete SDEV 106 Connections for College and Career Success (3 semester hours)  
OR
- Complete SDEV 103 Habits for Success (1 semester hour) and 63 104 Interdisciplinary Studies in Human Society (3 semester hours)

In order to exit the developmental program in each of the three academic areas, students must pass the required course(s) with a grade of "C" or better; or retake the placement assessment and achieve an appropriate score to test out of the developmental course requirements. Students may retake the corresponding section of the placement assessment after completing any developmental course, or, with the permission of the course instructor or the division chair, after completing at least one full week in an second-level developmental course (i.e., Math 93 or 96; Reading 93, 95, or 96; English 93, 94, 95, or 96). Developmental courses may not be taken more than three (3) times.

A student who elects to retake the placement assessment while enrolled in an upper-level developmental course will be charged a fee for the exam. If that student successfully exits the developmental sequence by scoring high enough to move to college-level courses in the corresponding discipline, then that student will be given a minimum of a "C" in the developmental course in which he/she was enrolled at the time of the exam retake.

**A3 Probational Admission**

- a. An applicant for admission who has had previous college experience or an applicant for readmission from Allegany College of Maryland will be admitted on academic probation if the college record reflects a probationary status within the last five-years.
- b. An applicant for admission who has been suspended once from any college may be admitted on academic probation with the approval of the Admissions Committee.
- c. A student who has been suspended twice from any college or colleges, regardless of whether attendance has been interrupted or not, normally shall not be eligible for admission to Allegany College of Maryland. However, admission of these students may be considered on an individual basis through the Admission Committee.

**A4 Specialized Program Criteria**

- a. Selective Admission Programs include, Dental Hygiene, Human Service Associate, Practical Nursing, Medical Assistant, Medical Laboratory Technology, Nursing, Occupational Therapy Assistant, Radiologic Technology, Respiratory Therapist, Physical Therapist Assistant and Therapeutic Massage.

Admission to and retention in Selective Admission Programs will be according to written and published program criteria.

- b. Final decisions regarding enrollment in these programs will rest with the Program Director and the admissions committee members.

**A5 Admission As An International Student**

- a. Through the U. S. Department of Homeland Security, the U. S. Citizenship and Immigration Services (USCIS) has determined that Allegany College of Maryland meets the eligibility requirements and has complied with the reporting requirements of Service regulations. It has been determined that the College is approved for attendance of F-1, F-2, M-1, M-2 academic and/or language students.
- b. A designated school official (Director of Admissions and Registration) must keep the following information and documents for each student and make them available to or furnish them to the USCIS upon request:
  - 1. The admissions number from the student's Form I-20 ID copy.
  - 2. Country of citizenship.
  - 3. Address and telephone number in the United States.
  - 4. Status, i.e., full-time or part-time.
  - 5. Course load.
  - 6. Date of commencement of studies.
  - 7. Degree program and field of study.
  - 8. Expected date of completion.
  - 9. Nonimmigrant classification.
  - 10. Termination date and reason, if known.
  - 11. The documents which show the scholastic ability and financial status on which the student's admission to the school was based.
  - 12. Information specified by the USCIS as necessary to identify the student, such as date and place of birth, and to determine the student's immigration status.
- c. The U. S. Citizenship and Immigration Services (USCIS) defines any person who is not a citizen or national of the United States as an "Alien." An alien who has been lawfully afforded the privilege of residing

## **Section Six: Academic Regulations**

permanently in the U.S. is a "Permanent Resident" (Immigrant). His or her status allows authorization for work and entitlement benefits. An alien who seeks temporary entry to the U.S. for a specific purpose is a "Non-Resident Alien" (Non-Immigrant). This category includes foreign government officials, visitors for business and pleasure, and students. Some non-immigrants have specialized employment privileges, for example, foreign nations who are employees of the U.S. office of a foreign-owned company.

Any person who is outside his country of nationality unable or unwilling to return to that country because of persecution or a well-founded fear of persecution is a "Refugee." Unlike asylees, refugees apply for and receive this status prior to entry into the U.S. An alien, already in the U.S. or at a port of entry, who is granted asylum in the U.S. is an "Asylee." Asylum may be granted to those persons who are unwilling or unable to return to their countries of nationality or to seek the protection of those countries because of persecution or well-founded fear of persecution.

- d. Several documents exist to explain or identify the bearer's intent and origin. INS explains the following as:

Passport: Travel document issued by competent authority showing the bearer's origin, identity, and nationality, which is valid for the entry of the bearer into a foreign country.

Visa: A travel document (stamp) issued by a U.S. Consul abroad, which authorizes the holder to apply for admission to the U.S. at a port of entry.

Form I-94, Arrival-departure Record: I-94 is issued to incoming aliens as evidence of alien registration and to identify them as legally permitted to enter the U.S. The conditions of their admission are indicated by the code, which reflects the classification, i.e. F-I.

USCIS Admissions Number: The number that is assigned to a non-resident alien when he or she enters U.S. at port of entry.

Green Card: A slang term describing the Alien Registration Receipt Card (Form I-151 or Form I-551).

I-20, Certificate of Eligibility for Nonimmigrant (F-I) Student Status for Academic and Language Students: This allows a student to apply for or maintain an F-I visa at a U.S. embassy outside the U.S. or for F-I status through USCIS the U.S. The I-20 may be issued only by the designated school official (Director of Admissions).

I-17: The form submitted by the College of those who are to act as DSO--Designated School Official.

- e. Immigration Status of those who may attend the College includes:
- F-1 (Student)--must be in full-time attendance.
  - F-2 (Dependent of Student)-- must be in full-time attendance.
  - M-1 (Nonacademic Student)--must be in full-time attendance.
  - M-2 (Spouse or Child of M-1 alien)--must be in full-time attendance.
- \*Work permitted under various conditions as prescribed in student and exchange visitor INS regulations.
- f. Students identified in "e" who request application for admission to Allegany College of Maryland must provide the following:
- TOEFL (The Test of English as a Foreign Language) Scores of at least 550.
  - Affidavit of Support Form I-134
  - Documentation of Health Insurance

- g. When the conditions of "f" have been met the student is sent an application for admission. At that point the conditions of Section A of this document apply to all students, including international students. When the application is filed with the Admissions Office, the DSO will issue an I-20.
- h. International students who have attended other institutions of higher education and wish to transfer credit to the College must provide official documents that include both the transcript and an official evaluation of foreign education credentials.

## **SECTION B: ADMISSION AS A NON-DEGREE STUDENT**

- B1 An applicant who does not wish to enter as a candidate for a degree or certificate may be admitted as a non-degree student to take courses to fit individual needs or interests. A non-degree student is not a candidate for either a degree or certificate.
- a. An applicant for admission as a part-time non-degree student must complete the appropriate application for admission.
  - b. An applicant for admission as a full-time non-degree student must complete the appropriate application for admission and furnish official transcripts covering all previous high school and college work. Non-degree applicants with an Associate's Degree or higher may present a copy of the diploma in lieu of an official transcript of grades.
  - c. A student, while classified as "early college," cannot be eligible for graduation at the completion of the fall semester. The student may however provide documentation from his/her high school verifying graduation and may participate in the spring commencement ceremony prior to the high school graduation date.
- B2 A non-degree student may become a degree or certificate student after (1) fulfilling the requirements of Regulation A1 or (2) accumulation of 6 credit hours with a cumulative GPA of 2.00 and the approval of the Director of Admissions & Registration. (All credits earned as a non-degree student will be included in the graduation evaluation if the student changes status to that of a degree or certificate candidate.)
- B3 Dual Enrollment (Early College Status)  
A high school student age sixteen (16) or over may be permitted to enroll at Allegany College of Maryland either as a full-time or part-time student under dual enrollment (early college status) with the following conditions:
- a. A part-time student must have (1) the written approval of the high school principal or guidance counselor and (2) completed all normal college admission requirements, including the College Placement Assessment or proper SAT/ACT scores.
  - b. A full-time student must have met the above conditions and have completed all high school graduation requirements, except fourth-year English.
- B4 Special Gifted and Talented Status  
In special circumstances, Allegany College of Maryland can accept, with approval from high school officials, a student under sixteen years of age who has attained a score of 1200 or more on the Scholastic Aptitude Test (SAT) or a score of 22 or more on the American College Test (ACT); or if the student has been identified by professionally qualified individuals as having outstanding abilities in the area of: (1) general intellectual capabilities; (2) specific academic aptitudes; or (3) the creative, visual, or performing arts.



## **Section Six: Academic Regulations**

Students who are under sixteen years of age must have written approval of parent or guardian and the Director of Admissions and Registration before the registration can be completed. The student must complete an Application of Special Admissions. The instructor will be notified prior to the beginning date of the class.

### **B5 Transient Status**

A transient student is one who has college credits earned elsewhere and is taking courses at Allegany College of Maryland for credit toward a degree at another college. Written authorization from the home institution is required to ensure transferability of credits, good academic standing, and financial clearance.

## **SECTION C: STUDENTS WITH ADVANCED STANDING**

### **C1**

- a. College credits completed at other accredited institutions recognized by the American Council on Education will be accepted for transfer subject to Regulations C2 through C6.
- b. College credits completed at a non-accredited college or university may be transferred at the discretion of the Director of Admissions & Registration after due investigation and consideration, guided by the general practice of the state's other accredited institutions in accepting or rejecting credits from the institution in question. Courses will be evaluated in accordance with Regulations C2 through C6.
- c. College-level work completed at an accredited educational agency such as the Armed Services, or recognition of prior learning through nationally recognized tests including CLEP, ACT-PEP, and Advanced Placement, with minimum allowable scores consistent with state minimum requirements, will be evaluated if appropriately documented and certified and if in accordance with Regulations C2 through C6.
- d. Credit-by-examination may be established on a matriculated student's record when the proper procedure is followed. This includes completion of the form, payment of fee, signatures of Program Director or Division Chair, and successful passing of the examination. Credit earned in this manner from other institutions will not be considered in meeting graduation requirements at Allegany College of Maryland.

C2 Transferable course work includes the courses equated with the same offered at Allegany College of Maryland, meeting the conditions of C1, and meeting graduation requirements in the student's curriculum or program.

### **C3**

- a. The College will give general education credits to a transferring student who has taken any part of the general education credits described in Regulation F1a of this document for any general education courses successfully completed at the sending institution and so identified by ARTSYS.
- b. Credit earned of a non-general education nature is transferable to the College if the cumulative GPA transferred averages a 2.00 or higher and if acceptance of the credit is consistent with the policies of the program.
- c. A student who has once been evaluated and received credit and then returns to the first institution, earns additional credit, and returns then to Allegany College of Maryland will be re-evaluated subject to Regulation C3 a and b.

C4 The maximum number of total credit hours allowable in transfer and/or credit by examination to Allegany College of Maryland may not exceed one-half the total number of semester hours required in the student's curriculum or program. A maximum of 15 semester hours of the minimum 60 semester hours required for the associate degree or a proportional amount of a greater number of hours will be awarded for credit for prior learning granted based on exams developed by the College. Exceptions to this regulation are subject to written approval of the Senior Vice President of Instruction and Student Affairs and the Director of Admissions & Registration.

- C5 Course content must be equivalent to a corresponding course offered at Allegany College of Maryland. The semester hours of credit granted for non-equivalent course work is subject to C4.
- C6 Neither quality points nor grades are accepted in transfer from another institution. Quality points will not be awarded for credit by-examination.
- C7 A degree/certificate seeking student at Allegany College of Maryland who plans to attend another college in a transient status and wishes to transfer credits back to Allegany College of Maryland cannot be guaranteed transferability of credits unless prior approval is obtained from the Registration Office. Maximum number of hours transferred must not exceed one-half the total number of semester hours required in the curriculum or program. Exceptions to this regulation are subject to written approval of the Senior Vice President of Instruction and Student Affairs and the Director of Admissions & Registration.
- C8 A student shall earn at least 30 semester hours of academic credit by direct instruction for conferral of a degree. A student shall earn at least 15 semester hours of academic credit at the institution granting the degree.
- C9 All credits earned in the state of Maryland are subject to the provisions of the Maryland Annotated Code when students are transferring to another Maryland college governed by the regulations of MHEC.

#### **SECTION D: READMISSION**

- D1 A student who has interrupted enrollment excluding the summer session must reapply.
- D2 The Chair of the Admissions Committee, in accordance with established policy, may act on cases of admission and readmission; however, when a student has applied for admission or readmission under the conditions of Section A3, the Chair shall give due notification of each action to the Admissions Committee.
- D3 Final decision in all admission and readmission cases will rest with the Admissions Committee.

#### **SECTION E: ACADEMIC RESPONSIBILITY**

- E1 Faculty may impose academic consequences in accordance with any and all relevant college instructional policies, including, but not limited to class rules and syllabi, Academic Regulations and the Code of Student Conduct.
- E2 If, in the professional opinion of the instructor, a student is disruptive to the learning environment, the instructor has the latitude to remove the student from the class on that day. If the student and instructor can arrive at a mutual agreement regarding classroom behavior, then the student (with the permission of the faculty member) will be allowed to return to class. If no such agreement is reached, then the instructor will communicate the details of the situation to the immediate supervisor who will provide the instructor with support and assistance, as needed. The student will also be referred to the immediate supervisor. If no resolution is found through the aforementioned discourse, the student will be dropped from the course; the student may initiate the academic grievance process. This process is independent of any disciplinary action connected to the Code of Student Conduct.

However, if the situation is excessively disruptive, aggressive, intimidating, out-of-control, or otherwise presents a safety risk to the instructor and/or other students, the instructor should immediately direct the disruptive student to leave the classroom, call 911 as needed, and notify campus security and/or the Dean of Student & Legal Affairs. After the class session is over, the instructor's immediate supervisor will be informed of the disturbance. The instructor may choose to drop the student from the course; the student may initiate the academic grievance process. This process is independent of any disciplinary action connected to the Code of Student Conduct.

**SECTION F: GRADUATION**

F1

- a. Each curriculum leading to the Associate's degree will have between 60 and 70 semester hours inclusive. To qualify as a candidate for the Associate's degree or a certificate, a student must satisfactorily complete all courses required in the curriculum as stated in the curriculum description in the College catalog. Each program leading to an A.A. (Associate in Arts) or A.S. (Associate in Science) must include not fewer than 30 semester hours in the following areas: Arts and Humanities (one course in each of two disciplines--6 credits); English Composition (one course minimum--3 credits); Social and Behavioral Sciences (one course in each of two disciplines--6 credits); Mathematics (3-4 credits); and Biological/Physical Science (at least one course must be a laboratory course--7-8 credits). Each program leading to an A.A.S. (Associate in Applied Science) degree must include at least 20 semester hours with a minimum of three semester hours in each of the following five areas: Arts and Humanities; English Composition; Social and Behavioral Sciences; Mathematics; and Biological and Physical Science.
- b. The student is required to satisfactorily complete all courses required in the curriculum as stated in the year of entry catalog or the graduation year catalog. If a student's enrollment at Allegany College of Maryland is interrupted by a break of 4 or more semesters excluding Summer sessions, the catalog in effect when the student reenters the College will be considered the year of entry catalog.
- c. Required courses in physical education are listed in the College catalog for each curriculum. A student will be exempted from physical education courses that involve physical activity based on medical documentation. The student must make up the total hour difference in meeting graduation requirements.

F2 A candidate for the Associate's degree or a certificate must:

- a. have a minimum cumulative quality point average of 2.00.
- b. be clear of any violations of the College policy on Code of Student Conduct.
- c. be in good academic standing.
- d. have satisfied all financial obligations to the College.

F3 A student who has completed at least one-half of the required coursework in a curriculum and wants to be admitted to candidacy for the Associate's degree can transfer back to the College the remaining required coursework. A student should contact the Associate Registrar to ascertain the transferability of coursework.

F4 Each candidate for the Associate's degree or a certificate should file an application online through the college website on or before the deadline date. Candidates filing after this deadline will be subject to a late fee and the applications must be received in the Registration Office no later than the end of the business day prior to the December, May and July Board of Trustees meetings. Late applicants who have paid the fee may participate in the ceremony if a cap and gown are available. They will not receive their actual diplomas at the ceremony.

F5 The student is encouraged to be present for commencement. The student who does not plan to participate in commencement must notify the Registration Office in writing no later than ten (10) calendar days prior to the date of commencement in order to graduate "in absentia."

F6 A candidate for the Associate's degree must satisfactorily complete all requirements established by the Maryland Higher Education Commission. This regulation supersedes catalog requirements that may not reflect current state guidelines.

F7 Any waiver of course requirements for graduation must be approved by the student's advisor, the department chair or program director responsible for the content of the required course, and the Academic Standards Committee. A waiver in requirements cannot decrease the total curriculum semester hour requirements. Students must still meet state graduation requirements even if a waiver is approved.

**SECTION G: HONORS**

G1 A candidate whose final cumulative point average is 3.80 or higher shall be graduated summa cum laude.

G2 A candidate whose final cumulative point average is 3.51 - 3.79 shall be graduated magna cum laude.

G3 A candidate whose final cumulative point average is 3.30 - 3.50 shall be graduated cum laude.

**SECTION H: GRADES AND SCHOLASTIC HONORS**

H1 The following grade system is used:

<u>Grade</u>	<u>Interpretation</u>	<u>Quality Points</u>
A	Outstanding	4
B	High	3
C	Average	2
D	Below Average	1
F	Failure	0
I	Incomplete	None
P	Pass (non-credit and designated credit courses only)	None
R	Registered to audit	None
W	Withdrawn	None
X	Deferred (See Regulation H7)	None

Note: All grades with the exception of "I" (Incomplete) are permanent grades.

H2 The grade of "I" (Incomplete) shall be used as a temporary grade whenever a student requests in writing and is granted permission to complete required coursework, including the final evaluation after the close of a semester or summer session. Such permission will be granted at the discretion of the instructor. A special form supplied by the Registration Office shall be used for this purpose. The grade of "I" will not be awarded at mid-term with the exception of classes as described in Regulation P4.

If the request for an incomplete is granted by the instructor, all work must be completed by a date specified by the instructor with concurrence of the Director of Admissions & Registration. All incompletes granted during the spring semester or summer session must be completed no later than 30 calendar days after the first day of fall semester classes. All incompletes granted during the fall semester must be completed no later than 30 calendar days after the first day of spring semester classes. Otherwise, the grade of "F" will be recorded by the Registration Office. An extension of time beyond the date specified may be granted upon written request with the concurrence of the instructor and Senior Vice President of Instruction and Student Affairs.

H3 The grade of "P" (Pass) will be recorded for satisfactory work in certain credit courses as indicated in the College catalog.

H4 The grade of "R" (Registered for audit) will be recorded at the student's request at the time of registration. A grade of "R" will be recorded automatically, unless the instructor advises the Registration Office in writing, via a drop form, that the student has failed to follow the instructions in the course syllabus. Failure to follow these instructions will cause a grade of "W" or "F" to be recorded on the student's transcript of grades.

H5 A student who is registered for credit for a course may change to audit the course until the first day of the tenth week of the semester. (The student must prepare a Course Registration Form and have it approved with

## ***Section Six: Academic Regulations***

the signature of the advisor and instructor to effect this change.) A student who is registered to audit may change to credit within the first week of class with instructor and advisor's approval.

- H6 The grade of "W" (Withdrawn) will be recorded under the complete circumstances listed in Section R: Withdrawal from Courses.
- H7 The grade of "X" (Deferred) will be awarded at the instructor's discretion to those students who, in the opinion have made some progress through reasonably diligent efforts, but have not attained proficiency sufficient for a passing grade. Such students are eligible to re-enroll at the beginning of any subsequent semester. Note: The "X" grade is a permanent grade. A student must re-enroll in a course to achieve a different letter grade. The grade of "X" will not be awarded at mid-term.

### **SECTION I: REPORTING AND RECORDING GRADES**

- I1 Grades for each student and for each course shall be reported by the instructor to the Director of Admissions & Registration at mid-term and at the end of each semester or session. "X" and "I" grades will be issued at the end of the semester or session. Midterm grades are not issued for the summer semester or A & B terms.
- I2 Midterm and final grades will be available online.
- I3 The semester grade as reported to the Registration Office at the end of the semester or session shall be final but may be changed within sixty (60) calendar days only if: (a) The instructor acknowledges in writing that there was an error in recording or computing the grade; or (b) the instructor explains fully in writing the special conditions or extenuating circumstances, which the instructor believes constitute sufficient justification for the grade change and obtains the written approval of the Senior Vice President of Instruction and Student Affairs.
- I4 A student's final grades do not constitute an official transcript and shall be withheld by the Registration Office if the student does not fulfill all financial obligations to the College.
- I5 If a student repeats a course, any earlier grade(s) shall remain listed on the student's permanent record and shall be included in all transcripts of credits.

### **SECTION J: QUALITY POINT AVERAGE**

The semester Quality Point Average and the Cumulative Quality Point Average shall be computed at the end of each semester. For Purposes of this section, semester hours refer only to college credit bearing courses numbered 100 or above.

- J1 A Semester Quality Point Average (QPA) is the total number of the quality points earned in the semester or summer session divided by the total number of semester hours attempted.
- J2 A Cumulative Quality Point Average (GPA) is the total number of quality points earned in all semesters or summer sessions divided by the total number of semester hours attempted.
- J3 If a student repeats a course, only the later grade shall be used in determining quality point average. However, in a final required course, should the first grade be passing and the repeating grade failing, ("F"), then the passing grade may be counted as satisfying graduation requirements for the course.
- J4 Only final course grades are used to compute cumulative point averages at the close of a semester or a summer session.
- J5 Quality points are not accepted in transfer from another institution.

- J6 To be eligible for the Dean's list, a student must have a semester QPA of at least 3.80, and the student must have carried a course load of at least five (5) semester hours.
- J7 To be eligible for the Honor's List, a student must have a semester QPA of at least 3.30 and less than 3.80, and the student must have carried a course load of at least five (5) semester hours.
- J8 Students who have discontinued attending Allegany College of Maryland for a minimum of five years and who decide to re-enroll to continue their education, may petition the Academic Standards Committee for approval to use the J8 regulation for deficient grades earned during previous enrollment. The student must submit a written request to the Director of Admissions and Registration requesting a review of his/her records to determine eligibility for grade forgiveness. If approved by the Academic Standards Committee, the student may have the grades for a maximum of 16 credits "forgiven" in terms of their impact on the student's GPA. Original grades are not expunged from the student's record; however, the courses are coded and the original grades will no longer be calculated in the student's grade point average. Students should work with an academic advisor to determine which courses they will select to be forgiven on their academic record. Grade forgiveness may be used no more than one time, regardless of the number of times a student may begin and discontinue enrollment at Allegany College of Maryland.

### **SECTION K: ACADEMIC PROBATION**

- K1 Any full-time student or part-time student with an accumulated total of 12 or more attempted semester hours must attain a semester quality point average of at least 1.75, or a cumulative quality point average of 2.00 to avoid being placed on academic probation.
- K2 A student on academic probation may not enroll for more than 14 semester hours.

### **SECTION L: REMOVAL FROM ACADEMIC PROBATION**

A student will be removed from academic probation if the student has attained a cumulative quality point average of at least 2.00.

### **SECTION M: SUSPENSION FOR POOR SCHOLARSHIP**

A student who has been placed on academic probation will be academically suspended if the student fails to attain at least a 1.50 semester grade point average. (See Regulation A3 for information on probational admission.)

### **SECTION N: STUDENT CLASSIFICATION**

- N1 A student carrying 12 or more semester hours is classified as a full-time student. A student carrying less than 12 semester hours is classified as a part-time student.
- N2 A student who has earned 28 or more semester hours of academic credits will be classified as a sophomore. A student who has earned less than 28 semester hours of academic credit will be classified as a freshman.

### **SECTION O: COURSE REPETITIONS**

- O1 A student may take and complete the same course for credit no more than three times. The most recent repeated grade will be computed in the student's grade point average. See regulation J3.
- O2 To receive credit for any course in which a grade of "F" was received at Allegany College of Maryland, the student must repeat and pass the course at this institution subject to the provisions of Regulations O1 unless permission for taking the course elsewhere has been granted in advance by the Director of Admissions & Registration.

## **SECTION P: REGISTRATION**

- P1 The College Calendar lists the dates for registration.
- P2 With instructor and advisor approval, a student will be permitted to enroll in a class during the first full week of class or five academic calendar days. A student will not be permitted to enroll in a class after the first week of classes unless under the conditions of Section P3.
- P3 A student may change classes until the end of the third full week:
- if the change is sections of the same course, or
  - if the course is within the same department and the change is recommended by the department.
- P4 Registration deadlines for classes with beginning and ending dates different from the regular semester dates will be adjusted in accordance with the deadlines of the regular semester.
- P5 Registration deadlines for A and B terms will follow the Academic Calendar.

## **SECTION Q: ACADEMIC LOAD**

A student may enroll for more than 19 semester hours in one semester, or for more than 12 semester hours for a summer session only upon receiving written permission from the academic advisor.

## **SECTION R: WITHDRAWAL FROM CLASSES**

- R1 To withdraw from a course(s) prior to the beginning of class/es, the student must prepare a Course Registration Form, have it signed by the advisor, and have it recorded in the Registration Office or process it online through the college website prior to the first day of class.
- R2 To withdraw from a course(s) after the beginning of class/es, the student must prepare a Course Registration Form, have it signed by the advisor and the instructor(s), and have it recorded in the Registration Office.
- R3 To withdraw from the College the student must prepare a Withdrawal Form, have it signed by the advisor, and have it recorded in the Registration Office or process it online through the college website prior to the first day of class.
- R4 A student may withdraw and receive "W" grades for all courses in a semester supported by medical documentation indicating that the student was unable to attend classes or effectively participate in class activities. The documentation must include dates.
- R5 Courses officially dropped within the first 20% of the course will not be included on the student's official transcript.
- R6 Courses officially dropped before the completion of 60% of the course will be recorded with "W" grades on the student's official transcript.
- R7 The official date of withdrawal is the date on which the completed Change of Schedule Form or Withdrawal Form is received in the Registration Office.
- R8 When absences endanger the student's progress in a course in the judgment of the instructor, the instructor may drop the student from the class roster. The instructor will notify the Registration Office, in writing, to this effect and the Registration Office will then notify the student. When a student is dropped by the instructor, Regulations R4 and R5 shall apply. When a student is dropped by the instructor after withdrawal deadline, a grade of "F" shall be recorded. (See Regulation U4).

- R9 If a student dies during the course of a semester, a grade of "W" will be recorded for each class. Also, any unresolved "I" grades on a deceased student's record will revert to "W" grade.

### **SECTION S: INSTRUCTIONAL PROGRAMS**

- S1 Each student will be classified as Non-Degree, Dual Enrollment (Early College), or Transient student, or will be placed in a specific curriculum.
- S2 A student wishing to change his/her curriculum must obtain a Change of Curriculum/Advisor form from the Registration Office, have the completed form approved by the advisor, and return the form to the Registration Office.

### **SECTION T: COURSE SUBSTITUTIONS**

- T1 A maximum of 12 credit hours may be substituted in a student's curriculum if approved by the student's advisor and the head of the department responsible for the course content. The content of the course being substituted must be at the same level or higher level than the course it replaces and both courses must be in the same department.
- T2 All course substitutions must be authorized in writing, and all correspondence citing the substitution must be forwarded to the Registration Office for inclusion in the student's permanent records.
- T3 Any substitution of curriculum course requirements cannot reduce the total curriculum semester hour requirements.

### **SECTION U: CLASS ATTENDANCE**

- U1 The student is required to attend every class session.
- U2 Permission to make up absences will be granted only at the instructor's discretion.
- U3 A student must notify the instructor as to the reason for an absence from a class session. The instructor may require evidence to justify an absence. Unexcused absences may adversely affect a student's grade in a course.
- U4 When a student's absences endanger the progress in a course in the judgment of the instructor, the instructor may drop the student from the class roster.

### **SECTION V: STUDENT RECORDS AND CONFIDENTIALITY**

- V1 The College will maintain student records in accordance with acceptable national standards regarding institutions of higher education.

The College will ensure the physical security and confidentiality of student records, and store physical records in fireproof cabinets. The College maintains a statement regarding the "Family Education Rights and Privacy Act of 1974 in the College Catalog.

The College will have adequate security to prevent loss of records maintained in electronic systems; and the College will have a document security plan appropriate to its record-keeping system.

- V2 The College adheres to a statement of the rights, privileges, and responsibilities of students, and makes this statement available to students through the catalog, student handbook, or other appropriate means.



**SECTION W: PETITION AND APPEAL TO WAIVE REGULATIONS**

W1 Whenever a student believes that application of any of these Academic Regulations (with the exception of Admissions and Readmissions and Financial Aid) is unwarranted in the individual case, the student may appeal to the Chair of the Academic Standards Committee through the Registration Office. Students who wish to appeal any regulation concerning admissions or readmissions may do so through the Admissions Committee and any student who wishes to appeal a financial aid regulation may do so through the Student Services Appeals Committee.

W2 The Academic Standards Committee and the Admissions Committee is empowered by the College to act in cases involving all academic regulations. The Committee shall notify the student, the advisor and appropriate instructors in writing of action taken and shall forward a copy to the Registration Office. The Committee shall submit a report of such cases at the end-of-year College staff meeting.

W3 A student whose petition is not approved by the Academic Standards Committee or the Admissions Committee may, after consultation with the advisor, appeal to the Director of Admissions and Registration by submitting a letter of appeal, signed by the student and the student's advisor.

A committee representative will contact the student, the advisor, and the Senior Vice President of Instruction and Student Affairs, to arrange to appear at the hearing on the petition. Following the hearing, a decision will be made by a majority of those members in attendance. The student and advisor will be notified by letter of the decision.

Any student whose appeal has been denied may appeal to the President and the President's decision is final. A copy of the President's decision will be sent to the Registration Office for inclusion in the student's record.

Revised May 2013



## **SECTION SEVEN: GRIEVANCE POLICIES AND PROCEDURES FOR STUDENTS**

### **I. Academic Grievance Procedure**

A student having a concern with a faculty member of an academic nature arising from participation in a credit class should follow this process:

**1. Review the course syllabus and Academic Regulations.**

Review the requirements and/or performance standards. Please take a few moments to make sure your concern is a valid one and is not based on inaccurate or incomplete information. Also please understand that this policy addresses issues of an academic nature, such as grades, attendance, or other academic issues relating to a course. This procedure must be initiated within 10 working days after occurrence. For issues that are non-academic in nature, students should refer to the appropriate College policy, which may be found in the Student Handbook.

**2. Talk with the faculty member.**

You **must** talk with the faculty member about your concerns. Schedule a meeting with the faculty member and meet with him/her. Chances are good that you can resolve a misunderstanding or other concern at this meeting. If you are unable to resolve the issue with the faculty member, contact the Program Director/Division Chair/Coordinator within 10 working days after meeting with the faculty member by following the directions in Step 3. Written documentation may be requested. The faculty member has the right to meet with involved individuals throughout each step of this process.

**3. Contact the Program Director/Division Chair/Coordinator.**

The director/chair/coordinator will verify that a meeting was held with the faculty member and then discuss the concern with you and the faculty member, either in person at the respective campus or by conference call. If unable to resolve the issue together, you may present your grievance to the Dean of Enrollment, Academic, and Student Services within 10 working days after you receive the decision of the director, chair, or coordinator by following the directions in Step 4. If the faculty member is the Program Director/Division Chair/Coordinator, see step 4.

**4. Contact the Dean of Enrollment, Academic, and Student Services.**

If you are dissatisfied with the Director/Chair/Coordinator's decision, you **must** take the following actions:

- Obtain the Academic Grievance Notice from the Office of the Senior Vice President of Instruction and Student Affairs, Student & Legal Affairs, your advisor, or online.
- Complete the Academic Grievance Notice. Include an explanation of why you believe the Director/Chair/Coordinator's decision was incorrect. Be specific.
- Schedule a meeting with the Dean of Enrollment, Academic, and Student Services.
- The Dean will obtain signatures from the faculty member and Director/Chair/Coordinator and notify them about the meeting. In the event that the faculty and Director/Chair/Coordinator refuse to sign the form because the matter was not discussed with them, the form will be returned to the

## **Section Seven: Grievance Policies for Students**

student and the student will be required to follow the procedures herein.

- Meet with the Dean of Enrollment, Academic, and Student Services.
- The Dean will make a decision based on the information contained in the Academic Grievance Notice and meetings with involved parties.

The Dean notes his/her decision on the Notice (with copies provided to all parties, and a copy maintained in the files of the Dean). If you are dissatisfied with the Dean's decision, you may appeal that decision to the Senior Vice President of Instruction and Student Affairs within 10 working days by following the directions in Step 5.

### **5. Contact the Senior Vice President of Instruction and Student Affairs.**

If you are dissatisfied with the Dean's decision, you **must** take the following actions:

- Submit a copy of the original Academic Grievance Notice with the Dean's decision to the Senior Vice President of Instruction and Student Affairs.
- Include an explanation of why you believe the Dean's decision was incorrect. Be specific.
- Schedule a meeting with the Senior Vice President of Instruction and Student Affairs.
- Meet with the Senior Vice President of Instruction and Student Affairs.
- The Senior Vice President will make a decision based on the information contained in the Academic Grievance Notice and meetings with involved parties.

The Senior Vice President notes his/her decision on the Notice (with a copy to the faculty member, Director/Chair/Coordinator, Dean, and a copy for the record.) If you are dissatisfied with the Senior Vice President's decision, you may appeal that decision to the President within 10 working days after receiving the decision of Senior Vice President of Instruction and Student Affairs by following the directions in Step 6.

### **6. Contact the President.**

If you are dissatisfied with the Senior Vice President's decision, you **must** take the following actions:

- Submit the Academic Grievance Notice with the Dean's and Senior Vice President's decisions to the President.
- Include an explanation of why you believe the Senior Vice President's decision was incorrect. Be specific.
- Schedule a meeting with the President.
- Meet with the President.
- The President will make a decision based on the information contained in the Academic Grievance Notice and meetings with involved parties.

The President notes his/her decision on the original Notice (with a copy to the faculty member, Director/Chair/Coordinator, Dean, Senior Vice President, and a copy for the record.)

**The President's decision is final.**

Approved by Board of Trustees 6/21/10

## **II. Employee Complaint/Misconduct Policy**

Any person (student, faculty, or staff) who has a complaint against a College employee must be able to communicate the complaint with confidence that it will be heard and acted upon appropriately - without risk of retaliation. Any person with a complaint about how an employee has conducted himself/herself in word or deed in his/her capacity as an employee of the College shall schedule a time to meet and discuss the complaint/concern with the particular employee. Informal resolution of concerns is permitted at this stage. If, however, the person does not feel his/her complaint has been redressed OR feels uncomfortable speaking privately with the employee, s/he should speak with the employee's immediate supervisor. The supervisor shall request a written account of the incident(s) and then identify the nature of the complaint to assess what action is needed.

OPTIONS THAT **MUST** BE CONSIDERED INCLUDE

- **notification** of the employee about whom the complaint is made;
- the possibility of misinformation or **miscommunication**.
- **review** of existing college policy/ies (e.g., academic grievance, sexual harassment, etc. ) with immediate referral to the designated College official,
- **consultation** with the President's legal advisor if legal implications exist;
- a **meeting** with the employee about whom the complaint is made;
- a mediated/facilitated **meeting** with the complainant and the employee;
- further **investigation** by the supervisor;
- **no action** because the complaint has no basis in fact, insufficient information is available, the matter has otherwise been resolved, or the employee acted correctly (which should be explained to the complainant); and
- **discipline** of the employee if warranted. (See the Employee Handbook's disciplinary policy for details on this process.)

The supervisor's finding(s)/action(s) shall be communicated - as privacy laws permit - to the complainant in writing. If the complainant is dissatisfied with the outcome, s/he may take the complaint to that person's supervisor and so on. The President's decision is final. All actions and/or findings shall be internally documented, including justification; however only disciplinary findings shall be noted in the employee's personnel file.

Approved by Board of Trustees 6/18/07

### III. Procedure for Appealing Denial of College Service(s)

The Allegany College of Maryland Student Services Appeals Committee processes concerns of students regarding financial aid, counseling programs, the main campus Child Care Center, the main campus Student Success Center and Pennsylvania campus Student Service Offices, and student activities. Matters that may be appealed include, but are not limited to, termination of financial aid, termination from a college work study, institutional work study, or tutoring position, denial of tutoring services, denial of child care services, residency classification for tuition purposes, denial of participation in student activities, and denial of services or accommodations for a disability. Appeals may only be considered by the Committee when a person is adversely affected by a final decision of a department director, coordinator, or manager. Warnings, reprimands, and other forms of non-conclusory actions may not be appealed.

A credit student having a concern regarding the areas listed above should first attempt to resolve the concern in an informal manner by:

1. Presenting the concern orally to the appropriate director, coordinator, or manager, who will make a written record noting the date of the oral statement of the concern, the College students and employees involved, any witnesses that might be helpful to resolution, and a brief description of the concern. The director, coordinator, or manager will make an investigation of the facts, if necessary, and provide the student with a written resolution.
2. If the resolution is unsatisfactory to the student, the student may appeal to the Student Services Appeals Committee.

## **Section Seven: Grievance Policies for Students**

3. If a student wishes to express a concern about termination of financial aid due to unsatisfactory academic progress after written notification, the student should appeal directly to the Student Services Appeals Committee without attempting an informal resolution of their concern as outlined above.

A credit student wishing to appeal a concern to the Student Services Appeals Committee should:

1. Obtain a form of petition before the Committee from the Office of the Dean of Student & Legal Affairs, and complete the petition, providing all of the information requested, as well as any additional information that might be helpful in understanding the concern. Attachments to the petition form that provide additional information are encouraged. The Dean of Student & Legal Affairs may provide advice on completing the written petition.
2. The student may elect to appear in person before the Committee, or direct the Committee to consider the appeal and reach a decision without an appearance before the Committee. The student is encouraged to attend so that the Committee may ask questions and obtain information not included in the written petition.
3. The Chairman or Secretary (Dean of Student & Legal Affairs) shall promptly schedule a meeting of the Student Services Appeals Committee and notify the student of the time and place of the meeting.
4. The Student Services Appeals Committee will meet and review the petition, conduct any investigation necessary, and deliberate the concern. The Committee renders a decision based upon a majority vote. The Dean of Student & Legal Affairs will prepare a written letter to the student advising of the Committee's action.

\* The decision of the Student Services Appeals Committee is final.

## **IV. Reporting Other Concerns**

Allegany College of Maryland relies upon students, employees, and visitors to report any concerns related to health, safety, or overall well-being to the appropriate college official\*. The College will accept all reports and take the appropriate action. The College will not retaliate against any person making a report and will not tolerate retaliation by others.

\*If you are more comfortable reporting the concern to another member of the ACM faculty or staff, you may do so, and that official may accompany you or otherwise support you in making the formal report.

### **Student Misconduct**

If you are aware of an act of misconduct under the Code of Student Conduct *or other inappropriate behavior* (on campus or off-campus) by a student, please contact Dr. Renee Conner, Dean of Student & Legal Affairs at (301) 784-5206 or rconner@allegany.edu . Please see the Code of Student Conduct (Section 8) for a detailed list of the standards of behavior expected of all Allegany College of Maryland students.

### **Crime**

If you are the victim of a crime or if you have information about the commission of a crime, please report the crime immediately.

- **Always call 911 in an emergency.**
- Contact Campus Security at (301) 784-5555
- Contact Cumberland Police Department at (301) 777-1600.
- You may also report by contacting the Office of Student Affairs at (301) 784-5206
- You can report anonymously on the Campus Security web page at [www.allegany.edu](http://www.allegany.edu)

See Section 1 of this Handbook for more detailed information about personal safety and Campus Security.

### Sexual Misconduct & Sex Discrimination

Allegany College of Maryland prohibits sexual misconduct and sex discrimination by or against all students, employees, and campus guests. If you have any questions or concerns or if you need to make a complaint, contact ACM's Title IX Coordinator, Dr. Renee Conner in CC-152, by email at rconner@allegany.edu, or by phone at (301) 784-5206. For detailed information about policy, procedures, and prevention education, see [www.allegany.edu/titleIX](http://www.allegany.edu/titleIX).

#### From the Policy:

- I. The College complies with applicable non-discrimination state and federal laws including Title IX as well as regulations prohibiting discrimination against any individual or group of individuals subject to legal protections. Title IX provides that "No person in the United States shall, on the basis of sex, be excluded from participation in, be denied the benefits of, or be subjected to discrimination under any education program or activity receiving Federal financial assistance." Sexual harassment and sexual misconduct are forms of sex discrimination under Title IX.
  
- IX. Any employee with information about sexual misconduct and sex discrimination shall report it promptly to Title IX Coordinator, Campus Security, other identified Title IX official, and/or the Office of Student & Legal Affairs. Any person with information about sexual misconduct and sex discrimination may report it to any Allegany College of Maryland official who shall promptly forward the report to Title IX Coordinator, Campus Security, other identified Title IX official, and/or the Office of Student & Legal Affairs. **The College strongly encourages any person who is a victim of or who witnesses any crime to contact law enforcement / call 911 immediately.**

#### Reporting:

##### **Who may file a report/complaint?**

Any person

##### **Who is required to report any knowledge of sexual misconduct or sex discrimination to the Title IX Coordinator?**

All identified Responsible Employees

*RESPONSIBLE EMPLOYEE:* any employee who (1) has the authority to take action regarding discrimination or sexual misconduct; (2) is an employee who has been given the duty of reporting discrimination or sexual misconduct, or (3) is someone another individual could reasonably believe has this authority or duty. The following Allegany College of Maryland Responsible Employees include the Title IX Coordinator, any Title IX investigators or team members, all administrators, all non-confidential employees in their supervisory roles, all faculty, all athletic coaches, all security guards, and all Residence Life staff members. Resident assistants, as quasi employees, are also deemed responsible employees. (NOTE: Per policy, no employee is excused from reporting sexual misconduct and sex discrimination.)

##### **To whom is a report/complaint given?**

Title IX Coordinator, Campus Security, members of the Title IX team, or the Office of Student & Legal Affairs

##### **How may a person file a report/complaint?**

By telephone, email, reporting form\*, or in person. Reports can also be made anonymously online; however, such reports are typically very difficult upon which to act, so providing a name and contact information is strongly recommended. Confidentiality will be protected to the greatest extent possible.

\*The reporting form is attached to this Procedure document.

##### **Do I have to give my name?**

If you are an employee forwarding a report/complaint from a complainant or other person with knowledge, your

## ***Section Seven: Grievance Policies for Students***

name and contact information is required. If you are a complainant or other person with knowledge, providing your name and contact information will help the College take the appropriate action; anonymous reports will be accepted but are much more difficult to resolve. Confidentiality will be protected by the Title IX Coordinator and/or Title IX investigators and team members to the greatest extent possible. ACM employees are required to forward reports/complaints as described above.

### **Can I get in trouble for reporting?**

No. Allegany College of Maryland prohibits retaliation in any form and against any person. Also, the College will not initiate disciplinary action against a complainant or witness who was under the influence of drugs or alcohol at the time of the reported sexual misconduct or sex discrimination. If another person makes a report/complaint against you, the College will apply the same policy/procedures to the new report/complaint.

#### Contact Information:

##### **Title IX Coordinator**

Dr. B. Renee Conner, Dean of Student & Legal Affairs  
12401 Willowbrook Road SE / Cumberland, Maryland 21502  
College Center #152  
(301) 784-5206 / rconner@allegany.edu

##### **Title IX Team**

John Morley, Security Coordinator  
12401 Willowbrook Road SE / Cumberland, Maryland 21502  
College Center #169  
(301) 784-5252 or (301) 784-5555 / jmorley@allegany.edu

Melinda Duckworth, Human Resources Director  
12401 Willowbrook Road SE / Cumberland, Maryland 21502  
College Center #166  
(301) 784-5230 / mduckworth@allegany.edu

Gerry Geil, Residence Life Director  
12401 Willowbrook Road SE / Cumberland, Maryland 21502  
College Center #155  
(301) 784-5368 / ggeil@allegany.edu

April Higson, Administrative Assistant for Athletics and Physical Education  
12401 Willowbrook Road SE / Cumberland, Maryland 21502  
Gym #166  
(301) 784-5265 / ahigson@allegany.edu

Chris Everett, Human Resources Generalist  
12401 Willowbrook Road SE / Cumberland, Maryland 21502  
College Center #166  
(301) 784-5158 / ceverett@allegany.edu

#### Office of Civil Rights:

A complaint of discrimination can be filed by anyone who believes that a school that receives federal financial assistance has discriminated against someone on the basis of race, color, national origin, sex, disability or age. The person or organization filing the complaint need not be the victim of the alleged discrimination, but may complain on behalf of another person or group.

For information on how to file a complaint with the United States Department of Education's Office of Civil Rights, visit <http://www.2.ed.gov/about/offices/list/ocr/complaintintro.html> or contact OCR's Customer Service Team at 1-800-421-3481

### **Discrimination**

Allegany College of Maryland does not discriminate against any individual for reasons of race, ethnicity, color, sex, religion or creed, sexual orientation, gender identity or expression, national origin, age, genetic information, familial status, disability or veteran status in the admission and treatment of students, educational programs and activities, scholarship and loan programs, or to terms and conditions of employment, including but not limited to, hiring, placement, promotion, termination, layoff, recall, transfer, leave of absence, compensation and training. Allegany College of Maryland complies with applicable state and federal laws and regulations prohibiting discrimination and Maryland prohibits retaliation in any form against any person who reports discrimination or who participates in an investigation.

If you are the victim of discrimination or if you have information about an act of discrimination perpetrated by the College, please contact Dr. Renee Conner, Dean of Student & Legal Affairs (and the College Title IX officer) at (301) 784-5206 or [rconner@allegany.edu](mailto:rconner@allegany.edu) .

### **Missing Student**

If you believe a student is missing or in danger, please report this concern immediately; both local law enforcement and the College will undertake immediate steps.

- **Always call 911 in an emergency.**
- Contact Campus Security at (301) 784-5555
- Contact Cumberland Police Department at (301) 777-1600.
- You may also report by contacting the Office of Student Affairs at (301) 784-5206

### **Student Health/Mental Health**

If you are experiencing personal health/mental health challenges or if you are aware of someone going through personal challenges, the College has resources to help. See page 17 of this Student Handbook for detailed information; also counseling brochures are located in racks across campus, and lists of resources are available in the Office of Student Affairs. You can also contact Dr. Renee Conner, Dean of Student & Legal Affairs at (301) 784-5206 or [rconner@allegany.edu](mailto:rconner@allegany.edu) . **Always call 911 in an emergency.**





## **SECTION EIGHT: CODE OF STUDENT CONDUCT**

**NOTE: THIS POLICY IS UNDERGOING REVIEW AND REVISION DURING THE 2015-2016 ACADEMIC YEAR. IF/WHEN THE POLICY IS CHANGED, STUDENTS WILL BE PROVIDED WITH UPDATED INFORMATION. IF ANY LANGUAGE IN THE POLICY PUBLISHED BELOW IS INCONSISTENT WITH FEDERAL OR STATE REGULATORY REQUIREMENTS OR LAWS (INCLUDING NEW PROVISIONS ENACTED DURING THE ACADEMIC YEAR), THE COLLEGE WILL COMPLY WITH AND DEFER TO THE APPROPRIATE FEDERAL OR STATE REGULATORY REQUIREMENTS OR LAWS.**

**YOU MAY CONTACT THE OFFICE OF STUDENT & LEGAL AFFAIRS, LOCATED IN ROOM 142 OF THE COLLEGE CENTER FOR THE MOST CURRENT INFORMATION.**

*June 2006 - Revised and approved by the Board of Trustees  
Updated (editorial corrections) April 2010 –BRC  
June 2013 - New Smoking Policy approved by Board of Trustees*

### **I. Philosophy**

Allegany College of Maryland, hereinafter referred to as “the College” is an institution of higher learning dedicated to excellence; as stated in the College’s mission statement, “Our focus is the preparation of individuals in mind, body, and spirit for lives of fulfillment, leadership, and service in a diverse and global society.” Consequently, the College accepts its responsibility to provide a meaningful, safe, educational environment not only in the classroom but also in the library, in the residence halls, in the cafeteria, in the gym, and anywhere else we find students, faculty, staff, and visitors. To fulfill that responsibility, the College presents this Code of Student Conduct, which demands high standards in our Core Values: Respect, Integrity, Opportunity, Wellness, and Quality.

### **II. Authority**

Allegany College of Maryland’s Board of Trustees adopts the Code of Student Conduct, and any changes to it must be approved by the Board of Trustees.

(NOTE: per standard practice, Board-approved Policies, Policy revisions, title corrections, wording corrections, grammar/punctuation corrections, formatting, and other non-substantive changes do not require Board approval.)

### **III. Jurisdiction**

The Code of Student Conduct applies to all students on any of the College’s campuses\* and to all students whose off-campus conduct (whether or not affiliated with the College or any College-sponsored activity) adversely affects the student’s fitness to be a member of the College community or is detrimental to the aims and objectives of the College. The Code of Student Conduct applies from enrollment (including between semesters) until the student graduates, withdraws from the College, or transfers to another institution without enrolling for further coursework at the College.

\*Main campus in Cumberland, Maryland; the Gateway Center in Cumberland, Maryland; Somerset County campus in Somerset, Pennsylvania; Bedford County campus in Everett, Pennsylvania; and Bedford County Technical Center in Everett, Pennsylvania.

## IV. Standard of Conduct and Policies

Students enrolling at any campus of Allegany College of Maryland assume an obligation to conduct themselves in a manner compatible with the College's function as an educational institution. Conduct shall be consistent with the College's Core Values: Respect, Integrity, Opportunity, Wellness, and Quality. Each student is presumed to have fundamental knowledge of proper conduct, such as manners, keeping hands to oneself, respecting the property rights of others, listening in class, and obeying authority. Each student is likewise expected to follow all federal, state, and local laws. Furthermore, each student shall be presumed to have read the Code of Student Conduct; ignorance of its provisions shall not be a defense to violating them. Finally, the actions/behaviors prohibited in the lists that follow are not exhaustive, since every possible conduct action/behavior cannot be foreseen by College officials, and the College reserves the right to supplement the standards of conduct at any time with notice to the students. Any questions about the Code may be addressed to the Dean of Student & Legal Affairs.

### A. Personal Interaction

Within the Standards of Conduct expected of all students at all campuses, the following actions/behaviors (and attempts to commit them) violate standards of personal interaction and are strictly prohibited:

1. Assault and Battery: touching (with one's hand or an object) another person without his/her consent, in anger, or in a way that puts any other person in fear of harm. If no actual touch occurs, the offense is assault.
2. Aggravated Assault: an assault and battery that results in serious injury.
3. Threat/Intimidation: words and/or actions that communicate to another person that s/he will be harmed in some way.
4. Sexual Assault: see the policy described below.
5. Sexual Harassment: see the policy described below.
6. Harassment: specific, offensive actions/behaviors (or combination of actions/behaviors) that are repeated at least three times and that have the intent or the effect of causing distress, anxiety, fear, or alteration of the actions, habits, or conduct of the person at whom the offensive conduct is directed.
7. Bullying: using one's power (of size, strength, reputation, position, finances, etc.) to dominate another person and/or to control his/her actions/behavior.
8. Other act(s) that violate the personal rights of another OR that violate any local, state, or federal law.

### Policy: Sexual Misconduct & Sex Discrimination

#### **BACKGROUND AND PURPOSE:**

Allegany College of Maryland is committed to providing a healthy and safe community for learning and engagement for all students, employees, and guests. It is the responsibility of every person to ensure his/her actions do not compromise the health and safety of any person or the campus community. Allegany College of Maryland takes discrimination, sexual misconduct, gender discrimination, and all forms of exploitation, harassment, and relationship violence seriously. This policy is designed to promote the prevention of such misconduct, to protect the well-being of the Allegany College of Maryland community, to stop reported misconduct, and to respond to any allegation of such misconduct with fundamental fairness. This policy incorporates both the civil rights and due process models for managing and investigating the forms of misconduct to which the policy applies. The College will adopt and follow procedures to fully implement this policy and to comply with federal and state laws and regulations including Title IX of the Education Amendments of 1972 as amended ("Title IX"), Title VII of the Civil Rights Act of 1964 ("Title VII" - employment discrimination based on sex including sexual harassment in the workplace), and the Jeanne Clery Disclosure of Campus Security Policy and Campus Crime Statistics Act ("Clery Act") which includes the Violence Against Women Act ("VAWA"). For purposes of this policy and related procedures, Title IX shall be the term to capture all these laws which implicate sexual misconduct and sex discrimination.

**POLICY:**

**I. Non-Discrimination Statement**

The College complies with applicable non-discrimination state and federal laws including Title IX as well as regulations prohibiting discrimination against any individual or group of individuals subject to legal protections. (See the College's general non-discrimination policy.) Title IX provides that "No person in the United States shall, on the basis of sex, be excluded from participation in, be denied the benefits of, or be subjected to discrimination under any education program or activity receiving Federal financial assistance." Sexual harassment and sexual misconduct are forms of sex discrimination under Title IX.

**II. Prohibition of Sexual Misconduct, Sex Discrimination, and Retaliation**

Allegany College of Maryland prohibits all forms of sexual misconduct and sex discrimination which includes but is not limited to sexual violence, sexual harassment, gender-based harassment, dating violence, domestic violence, sexual exploitation, sexual intimidation, and stalking. Sexual misconduct is a form of sex discrimination prohibited by state and federal laws. These acts may also constitute crimes which could be reported to local law enforcement. College also prohibits retaliation in any form against a complainant, respondent, witness, investigator, or any other person associate with a report. The College complies with applicable state and federal laws including the Clery Act as well as related regulations. Nothing in this policy shall be construed to permit other behaviors expressly prohibited by the Code of Student Conduct or Employment policies.

**III. Institutional Obligations**

The College will take steps to prevent the occurrence of sexual misconduct and sex discrimination. If sexual misconduct and/or sex discrimination occurs, the College – upon receiving notice – shall take immediate, appropriate steps to end the misconduct and/or discrimination, to prevent its recurrence, and to remedy its effects. The College shall encourage any crime to be reported to the appropriate law enforcement agency; the College shall cooperate with criminal investigations to the greatest extent permitted by law; and the College shall comply with all Clery mandated data collection and reporting requirements. The College's institutional response to sexual misconduct and/or sex discrimination shall be independent of any law enforcement and/or court action. All College employees are required to report any sexual misconduct and/or sex discrimination in accordance with the policy provision specified below.

**IV. Procedures**

Allegany College of Maryland shall adopt comprehensive procedures to implement this policy. Such procedures shall include but are not limited to the following elements: definitions of terms (particularly any terms by federal and/or state authorities), how to file a complaint, responsible employees, the role of law enforcement/crime reporting, interim measures, confidentiality, notifications of parties, prompt and fair preliminary inquiry and investigation practices, prohibited investigation activities, timelines, possible remedies, possible resolutions/consequences, resources, and record-keeping.

**V. Title IX Coordinator**

Allegany College of Maryland's Title IX Coordinator is responsible for the College's compliance with federal and state laws and/or regulations related to Title IX and the Clery Act as enacted in this policy and accompanying procedures. The Title IX Coordinator shall be the Dean of Student & Legal Affairs whose name and contact information shall be included in accompanying Procedures as well as publications and educational/training materials for students, faculty, and staff. The College may identify additional College employees to function as Title IX officers or team members to assist with the implementation of this policy and to conduct investigations as needed; contact information for these employees will also be published in appropriate materials. Inquiries concerning the application of Title IX may be referred to the Title IX Coordinator, and complaints that the College has discriminated on the basis of gender may be made to the Office for Civil Rights.

**VI. Education and Training**

Allegany College of Maryland shall provide ongoing prevention and awareness education to students, faculty, staff, and other relevant parties. This education shall be designed to inform the campus community about what constitutes sexual misconduct and sex discrimination, how to reduce the occurrence of sexual misconduct and sex discrimination, safe bystander interventions, consequences of engaging in sexual misconduct and sex discrimination, and how to report sexual misconduct and sex discrimination. The College shall also secure or provide annual training for College employees who are charged with responding to, investigating, and/or adjudicating sexual misconduct and sex discrimination.

**VII. Application of the Policy**

This policy applies to (1) all Allegany College of Maryland students, faculty, staff, and third parties under the College’s control; (2) any College-owned or College-managed facility or property; (3) any College sponsored, recognized, or approved program, visit, or activity regardless of location; (4) any policy-defined misconduct that impedes equal access to any College program or activity; (5) any policy-defined act of sexual misconduct and sex discrimination that adversely impacts the health, safety, and/or employment of a member of the College community. The College shall provide notice of this policy to students, employees, applicants, and other relevant persons.

Application of this policy may directly or indirectly require the application of other institutional policies; nothing in this policy shall be construed to prohibit the application of related policies which include, but are not limited to the policies listed here. If the application of this policy conflicts with the application of another institutional policy, College will make a good faith effort to comply with all mandates; however, this policy shall take precedence unless otherwise required by law. Related policies: Code of Student Conduct, Personnel/HR policies, Non-Discrimination Policy, Admissions Policy, Safety Risk Policy, FERPA Policy, and First Amendment Policy.

**VIII. Policy Changes**

Substantive changes to this policy require approval by the Board of Trustees; editorial changes, title/position changes, and/or changes to its implementation procedures may be made as required by federal or state mandate and/or institutional need with timely notice to students and employees.

**IX. Reporting**

Any employee with information about sexual misconduct and sex discrimination shall report it promptly to Title IX Coordinator, Campus Security, other identified Title IX official, and/or the Office of Student & Legal Affairs. Any person with information about sexual misconduct and sex discrimination may report it to any Allegany College of Maryland official who shall promptly forward the report to Title IX Coordinator, Campus Security, other identified Title IX official, and/or the Office of Student & Legal Affairs. The College will assist any person needing assistance to make a report or complaint. The College strongly encourages any person who is a victim of or who witnesses any crime to contact law enforcement / call 911 immediately.

If you have any questions or concerns or if you need to make a complaint, contact ACM’s Title IX Coordinator, Dr. Renee Conner in CC-152, by email at [rconner@allegany.edu](mailto:rconner@allegany.edu), or by phone at (301) 784-5206. For detailed information about policy, procedures, and prevention education, see [www.allegany.edu/titleIX](http://www.allegany.edu/titleIX).

**B. Respect for Property**

Within the Standards of Conduct expected of all students at all campuses, the following actions/behaviors (and attempts to commit them) violate standards for respect of property and are strictly prohibited:

1. Theft/Unauthorized Use: if the property does not belong to you, then you may not take, use, tamper or move it without the permission of its owner. Also, no one may possess or assist in the concealment of stolen property.

## **Section Eight: Code of Student Conduct**

2. Trespassing: if a student has been advised orally or in writing by a College official that s/he is not permitted on campus, at housing, or in a particular location of the College, then the student may not enter that property without advance permission by an authorized College official.
3. Unauthorized Entry: if the room, apartment, or building has not been opened to you by the person/entity authorized to admit you, then you may not enter. No one may demand entry to any room, apartment, or building.
4. Breaking and Entering: no one may forcibly enter a room, apartment, or building. "Force" includes (but is not limited to) kicking doors, picking locks, opening windows, and threatening occupants.
5. Robbery: stealing the property (including money) of another person through force, threat, or intimidation.
6. Vandalism: intentionally causing damage to the property of another person or the College. Unintentional damage will not result in disciplinary action, but the person(s) responsible will be required to pay for repair/replacement.
7. Other act(s) that violate the property rights of another OR that violate any local, state, or federal law.

### **C. Health and Safety**

Within the Standards of Conduct expected of all students at all campuses, the following actions/behaviors (and attempts to commit them) violate health and safety standards and are strictly prohibited:

1. Weapons: No one may possess or use on College property any firearms, guns (including BB guns), knives (except a penknife without switchblade), other dangerous or deadly weapons of any kind, explosive ammunition, or incendiary/explosive material or device (except as expressly permitted by the President). Also, if an ordinary usage item is wielded as a weapon, then it will be treated as a violation of this standard.
2. Disregarding Fire Safety: the College complies with mandates and recommendations of the fire marshal. Equipment is in place for the protection of all people on campus. Violations include tampering with equipment, pulling false alarms, playing with fire extinguishers, removing fire extinguishers from their designated locations, dismantling smoke detectors, removing batteries, hanging items from sprinkler heads, using fireworks (including sparklers), and failing to evacuate a building when a fire alarm has sounded.
3. Drugs: the College has a zero tolerance for illegal drug use. (See the Alcohol and Drugs Policy below for more information.) "Drugs" includes the possession, use, distribution/dispensation, and manufacture of any controlled substance (including residue or trace amounts) as defined by state or federal law.
4. Alcohol: the College does not tolerate the use or possession of alcoholic beverages by anyone under the age of 21. People over age 21 may consume alcoholic beverages only at events wherein the use of alcoholic beverages has been approved by the President. **No one** may use or possess alcoholic beverages on the grounds of Willowbrook Woods. (See the Alcohol and Drugs Policy below for more information.)
5. Tobacco: smoking and/or the use of other tobacco products is limited. (See the Tobacco Policy and Housing Regulations below for more information.)
6. Reckless Endangerment: unsafe act(s) that place any person at risk of injury.
7. Child Endangerment: the College often has children on campus, and no one may engage in activities that put any child at risk of physical, medical, or psychological harm. Only authorized persons are permitted entry to Campus Kids Child Care Center. All students bringing children onto campus should read the Unattended Children Policy below.
8. Enabling Dangerous Persons: the College sometimes designates certain individuals to be too dangerous or disruptive to be permitted onto campus. Such persons may be non-students (i.e., see the Dangerous Persons on Campus Policy) or may be a current or former student whose presence on campus or certain locations on campus have been restricted (e.g., evicted residents at Willowbrook Woods). Students may not assist these persons in getting access to areas they have been denied.
9. Unauthorized Possession/Duplication of keys: only keys given to a student by an authorized College official may be used; no keys may be duplicated.
10. Traffic Obstruction: roadways, sidewalks, hallways, doorways, and stairs must be free of obstruction for both vehicular and pedestrian traffic.

11. Unsafe driving: all students are expected to follow the posted speed limits and other rules of the road when operating a motor vehicle on campus.
12. Unauthorized Parking: the parking of a motor vehicle in a location where parking is restricted or not permitted. Staff parking is designated for use only by faculty and staff. Handicapped parking is designated for use only by persons with authorized handicapped tags/stickers.
13. Animals: See the Pets and Animals Policy below for more information.
14. Spreading Infectious Disease: Failure to report an infectious disease/condition as required jeopardizes the entire College community. See the Infectious Disease Policy below for more information.
15. Other act(s) that violate the health and safety rights of another OR that violate any local, state, or federal law.

**Policy: Alcohol & Drug Use**

Allegany College of Maryland supports the efforts of the State of Maryland and the United States to provide workplaces and learning centers free of illicit drug use and free of unlawful alcohol use. The College supports the Federal Drug-Free Workplace Act of 1988, the Federal Drug-Free Schools and Communities Act Amendments of 1989, and drug and alcohol abuse policies of the Maryland Higher Education Commission.

It is the College's intention to provide and maintain a work environment for employees and students that is drug-free, healthful, safe, and secure. When a student is on campus, the student is expected to be in an appropriate mental and physical condition, free of any illegal drugs/alcohol and capable of fulfilling their daily duties. The unlawful manufacture, distribution, dispensing, possession or use of a controlled substance (as defined by the Controlled Substance Act 21 U.S.C. section 802 and further defined at 21 C.F.R. sections 1300.11 - 1300.15) and the unlawful possession or use of alcohol on College property or as part of any College-sponsored activities off-campus is absolutely prohibited. Any unlawful activity with controlled substances or alcohol by students while involved with a College activity, on or off the campus, will not be tolerated.

Although the College recognizes drug/alcohol dependency as an illness and a major health problem affecting society, it also recognizes drug use and activity as a potential health, safety, and security problem. Students requiring assistance in dealing with drug or alcohol abuse or dependency are encouraged to seek counseling and/or medical assistance through the use of the College's health insurance plan, as may be appropriate, or through the Student Assistance Program which offers counseling and referral.

Certain student financial aid awards may only be made if the student is willing to certify or pledge that they will not engage in unlawful activities with regard to drugs and alcohol.

Violations of this Policy statement shall be immediately addressed by the College and may result in disciplinary action which could include expulsion. The College may also refer violations for criminal prosecution by civil authorities where circumstances warrant.

**Policy: Tobacco and Smoking** (Approved by the Board of Trustees 6/17/13)

**PURPOSE AND BACKGROUND:**

It is a shared responsibility of the students, staff, and visitors of Allegany College of Maryland to promote a healthy, comfortable, productive, and safe campus environment. Reliable medical evidence reveals that smoking and tobacco use is hazardous not only to the health of those who use the products, but tobacco smoke is also hazardous to the health of nonsmokers who are exposed to smoke. Additional health concerns relative to the use of tobacco, tobacco products, and tobacco substitutes include oral cancer, allergic reaction/allergies by non-users who are exposed, communicable diseases which may be transmitted by contact with body fluids and sputum produced during oral tobacco use which can provide the vehicle for infection, and the lack of medical research into the risks, if any, to users and non-users of tobacco substitutes such as e-cigarettes.

Thus, it is the position of the College that the use of tobacco, tobacco products, or tobacco substitutes is harmful not only to the person consuming/using it but also to others. In an effort to promote health and to preserve the

working/learning environment of the campus community, all students, staff, and visitors to Allegany College of Maryland are required to comply with the provisions of this policy. In all matters related to the implementation and enforcement of this directive, reasonable priority shall be given to the needs of nonsmokers/non-users.

Allegany College of Maryland's former policy restricted the use of tobacco, tobacco products, and tobacco substitutes to parking lots; this policy was approved by the Board of Trustees in November 2007. Due to ongoing health and enforcement concerns, a Smoke Free Task Force comprised of faculty and staff was appointed in Fall 2011; in Spring 2012, the Task Force recommended that Allegany College of Maryland campuses go tobacco-free.

### **POLICY**

**Policy Statement:** No person shall use tobacco, tobacco product(s), and/or tobacco substitute(s) on any property owned, operated, or managed by Allegany College of Maryland including – but not limited to – buildings, parking lots, vehicles, and fields/lawns. This policy applies to all forms of tobacco, tobacco products, tobacco substitutes, and tobacco delivery devices – regardless of whether the delivery device is being used with tobacco or nicotine. Hereinafter, the use of the word “tobacco” in this policy and in any procedures which are developed shall encompass all the products listed in “Definitions” below.

The only exceptions to this policy are (a) smoking/tobacco cessation products such as nicotine patches, gum, physician-prescribed medications, or similar approved product and (b) exceptions expressly permitted by the College President or designee.

### **Definitions:**

➤ **Tobacco, tobacco, tobacco product(s), and/or tobacco substitute(s)**

The intent of this policy is to be broadly applied to the following products:

- Cigarettes, cigars, cigarettos, pipes, chewing tobacco, snuff, snus, dissolvable tobacco, other smokeless tobacco;
- Nicotine;
- e-cigarettes, electronic nicotine delivery systems, hookahs, and other devices whose products are inhaled and/or which produce a vapor;
- any product which is designed to mimic the act of smoking without using actual tobacco or nicotine;
- any tobacco-, nicotine-, or smoking-related product which has an actual or potential effect upon a non-user;
- any tobacco-, nicotine-, or smoking-related product existing at the time the policy is adopted; and
- any tobacco-, nicotine-, or smoking-related product which may be developed in the future.

➤ **Vehicle**

This policy applies to all vehicles operated, idling, or parked on campus including College-owned vehicles, College-owned golf carts, other College-owned motorized equipment, delivery/business vehicles, and personal vehicles.

➤ **Smoking Cessation Product**

The intent of this policy is to encourage the students, staff, and visitors to quit using/consuming the products prohibited on campus by this policy; therefore, legitimate smoking cessation products are permitted. Preference will be given to any such product approved, endorsed, and/or provided by local, state, and federal agencies such as the Food & Drug Administration and the Allegany County Health Department.

**Education:** The College shall purchase or produce signage of sufficient quantity and quality to inform all persons on campus about the policy. Signage shall be posted in prominent locations on all campus locations/property, and information about the policy and smoking cessation opportunities shall be included in relevant publications and electronic media. When appropriate, the College will promote education to students, faculty, and staff about the health risks associated with tobacco and related products; when funding is available, the College will provide smoking cessation resources to students, faculty, and staff.

Allegany College of Maryland encourages all consumers/users of tobacco to quit; those who do not shall be responsible for locating an alternate location to consume/use tobacco, and the College accepts no liability for their choice to consume/use tobacco on non-College property.

**Enforcement:** All students, faculty, and staff share in the responsibility for adhering to and enforcing this policy. Informal enforcement may be used via courteous reminders for first time violators. Formal enforcement for students, faculty, and staff who repeatedly violate the policy or who fail to comply with informal measures may occur via the Code of Student Conduct (students) and the College HR Manual (employees). Campus visitors who fail to comply with informal measures may be asked to leave College property and may not be permitted to return.

Related Allegany College of Maryland policies maintain their full force and purpose (eg., FERPA, HIPAA, Code of Student Conduct, Employee Handbook, Employee Complaint Policy, Safety Risk Policy, etc.). Nothing in this policy shall be deemed to permit or authorize the use of smoked/inhaled drugs including, but not limited to, marijuana; illegal drugs and/or the unauthorized use of legal drugs are not permitted on any property owned, operated, or managed by Allegany College of Maryland, nor is any person permitted to be on College property under the influence of drugs (or alcohol).

**Information: Littering**

Allegany College of Maryland provides trash cans and tobacco receptacles on its campuses. Each person using College facilities is expected to dispose of his/her trash properly (including tobacco products).

**Policy: Unattended Children**

In an effort to protect the health and safety of students, faculty, and staff at the Main Campus in Cumberland, Bedford County and Somerset County Campuses in Pennsylvania, and all other campus sites of the college, all persons doing business on this campus or either of its Pennsylvania Campuses are reminded that they are responsible for any minor children brought to the Campuses. No unattended children are allowed on campus.

Even if a child\* is in the company of an adult, the child may not accompany the adult to a class and/or laboratory. There is a very plausible reason for this and it is a matter of safety (Fire Marshal's mandate the number of persons allowed in each classroom and that number may not be exceeded). Additionally, the child's presence may disturb other students in the class.

\*Child = Any person under the age of eighteen, who is not registered as a credit or continuing education student at the College.

Efforts to have children cared for elsewhere are the responsibility of the student. Allegany College of Maryland staff members may have additional information about other childcare resources.

**Policy: Dangerous Persons on Campus**

Allegany College of Maryland strives to provide quality education and services in a safe and comfortable environment at a reasonable cost. Anyone who satisfies our admissions criteria and who is at least sixteen years of age is admitted to Allegany College of Maryland. The College reserves the right to refuse admission or re-enrollment or to place conditions on admission or re-enrollment of applicants and former students who the College determines represent a safety risk to students, faculty, or staff. Allegany College of Maryland also strives to promote a college that enhances lives and the community through education and service. We welcome the public and service providers to our campus. All visitors are expected to conduct themselves appropriately and lawfully at all times. The College reserves the right to deny entrance to the College or to remove persons from the College grounds who pose a safety risk to our students, faculty, staff, other visitors, or property.

**Policy: Pets and Animals**

Bringing pets or animals onto College properties or into buildings without the express permission of the Physical Plant Department is prohibited. Pets and animals are strictly prohibited from Willowbrook Woods – except for fish in the maximum of a 10-gallon tank.



## **Section Eight: Code of Student Conduct**

### **Policy: Infectious Diseases/Conditions**

This policy concerns infectious diseases/conditions that include (but are not limited to) measles, chickenpox, other rashes with fever, lice, hepatitis, flu pandemic, impetigo, pink eye, jaundice, and the like.

In an effort to protect the health and welfare of students, staff, and faculty at Allegany College of Maryland, students, staff, faculty, and their children who exhibit signs and symptoms of potential, acute communicable illnesses may not remain on campus and will be excluded from public areas, classrooms, laboratories, college offices, and housing until the acute and/or contagious stage is over. (That determination must be made by a physician or Health Department official, who must provide written verification.) Exclusion from campus during this period will not only facilitate the recovery of the affected person, but it will also protect others from possible transmission to other persons, particularly those whose immunity to disease is already compromised (e.g., persons undergoing treatment for leukemia and other forms of cancer).

It is the responsibility of the infected individual to notify the Dean of Student & Legal Affairs\* of the illness. The person will be asked to provide essential information such as when the illness/condition was contracted, from whom the illness/condition was contracted, and with whom the infected person has had contact. The Dean of Student & Legal Affairs will coordinate any campus-wide response that is needed with the appropriate officials (e.g., Health Department officials, the Vice President of Finance and Administration, the Senior Vice President of Instruction and Student Affairs, the Director of Residence Life, etc.) *If necessary, Allegany College of Maryland will close until the medical crisis has passed.*

\*On the Pennsylvania campuses, the Director of Student Services will accept notification and coordinate response.

Assuming hospitalization or other quarantine is not required, students will be encouraged to go to their permanent homes during this time and to contact their instructors to make arrangements for their assignments, tests, and other academic obligations. Please consult the relevant section of this Handbook and course syllabi for attendance policies.

### **D. Peace and Order**

Within the Standards of Conduct expected of all students at all campuses, the following actions/behaviors (and attempts to commit them) violate standards of peace and order and are strictly prohibited:

1. Failure to Comply: when a student is given an order, direction, or instruction from a College official or a community authority (such as fire and rescue personnel) who is rendering assistance to the College, the student must follow the order, direction, or instruction.  
(If the student objects to it, s/he must comply but may lodge a complaint with the official/authority or with the Dean of Student & Legal Affairs on the next business day.)
2. Probation Violation: failure to observe a term or condition of probation issued in a previous disciplinary matter.
3. False Statements: there are many occasions when a student is required to be truthful and honest with College officials. Violations include knowingly making a false report, giving false information during an investigatory interview, and/or falsifying a College document.
4. Fraud: certain actions/behaviors that are intended to deceive College officials or to gain access to facilities, equipment, offices, etc. constitute fraud. (See Terms and Conditions for Use of Internet for an example.) Also, no student shall engage in the forgery, adulteration, or misuse of any College document or record.
5. Disorderly Conduct: students shall not engage in actions/behavior that disrupt educational or administrative operations of the College. (See Classroom Behavior Policy for an example.)
6. Inappropriate/Unauthorized Use of Computer(s): the use of any computer to harass, intimidate, abuse, or embarrass any other person OR the use of another person's identity/access/password OR the misuse of internet privileges. (See Technologies Resources Policy).

7. Residence/Residency: Providing false, misleading, incomplete, or inaccurate information to solicit a change in legal residency is not permitted. Moving to Maryland and/or Allegany County solely for the purpose of obtaining a reduced tuition is not permitted. Also, each student is required to notify the Admissions/Registration Office of his/her permanent and local addresses – including any changes of addresses within a reasonable time. Willowbrook Woods may NOT be listed as a permanent address.
8. Unauthorized Publication(s)/Sale(s): Except as authorized in College policy or one-time, private transactions involving personal property, students are not permitted to sell merchandise without prior approval from the Dean of Student & Legal Affairs. Entrepreneurs who wish to engage in the routine sale of goods shall obtain a local business license.
9. Other act(s) that violate peace and order OR that violate any local, state, or federal law.

**Information: Classroom Behavior**

Faculty may enforce their own classroom/syllabus rules and have discretion to impose academic consequences in accordance with relevant college instructional policies per the Academic Regulations. Faculty members who have concerns about a student's discourteous or disruptive conduct in the classroom (or other class-related setting) are encouraged to follow the procedures detailed in Section E: Academic Responsibility related to academic consequences.

However, if the problem behavior is excessively disruptive, aggressive, out-of-control, or otherwise presents a safety risk to the instructor or other students, the faculty member shall immediately direct the student at fault to leave\* the classroom, call 911 as needed, and then notify either security or the Dean of Student & Legal Affairs, who may initiate disciplinary action. The faculty member may elect to withdraw the student, subject to the Academic Regulations.

(\*In unusual circumstances, it may be wiser to evacuate the classroom, leaving the disruptive student alone for intervention by the proper authorities.)

**Policy: Use of Cellular Telephones**

While the use of cellular telephones on the campuses of Allegany College of Maryland is generally permitted, there are certain situations in which cellular telephone use becomes disruptive. The following, non-exhaustive list contains examples of places/times when the use of cellular telephones is not permitted: all classrooms, lecture halls, and laboratories; all libraries and other areas used as "quiet study" places; and events in the College theatre where hosts have requested that all cellular telephones be turned off.

Out of courtesy to your instructors, fellow classmates, and College staff, Allegany College of Maryland encourages you to use your judgment as to the appropriateness of the use of your cellular telephone while on campus.

**Policy: Technology Resources Policy**

See Computer Services.

**Policy: Student Publications and Sales**

See Student Life.

**E. Housing Regulations**

In addition to the policies and rules of conduct applicable everywhere on the College's campuses, student housing has particular regulations that are necessary for the safety and harmony of that community. It is the responsibility, however, of every student to know and follow these regulations when they visit Willowbrook Woods.

1. PHOTO IDENTIFICATION CARDS
  - All residents must have a College ID card.
  - All residents must carry this ID card at all times.
  - ID cards must be shown if and when requested by any official.

## **Section Eight: Code of Student Conduct**

2. Everyone entering Willowbrook Woods must show a photo ID; visitors' IDs will be kept by security until the visitor departs. The visitor must sign in and out.
3. GUESTS  
All residents and visitors must follow Guest Policies and Procedures.
4. QUIET HOURS AND COURTESY HOURS
  - Courtesy hours are in effect at all times; courtesy hours indicate a general respect for others' sleep, study, and lifestyle habits.
  - Quiet hours are times when noise should not be heard outside the apartment, and noise in breezeways/balconies should be kept to a bare minimum.  
Designated Quiet Hours: 11:00 pm to 8:00 am Sunday thru Thursday  
12:00 am to 11:00 am Friday and Saturday  
24 hours during mid-term and final weeks
5. ALCOHOLIC BEVERAGES ARE PROHIBITED.
6. Per the Tobacco-Smoking policy approved by the Board of Trustees, SMOKING AND TOBACCO USE (INCLUDING TOBACCO SUBSTITUTE PRODUCTS) ARE NOT PERMITTED on Willowbrook Woods property
7. An extensive list of ITEMS BANNED from apartments is provided to each resident. (Examples include candles, incense, fireworks, dart boards, and grills.) Guests should bring nothing on housing property without checking that the item is permitted.
8. Per the fire marshal, NO MORE THAN 10 PEOPLE ARE PERMITTED in an apartment at any time.
9. CARS MUST BE REGISTERED; unregistered cars will be towed.

## **V. Enforcement of Policies**

Except for academic violations which are enforced as described above, the Dean of Student & Legal Affairs (i.e., Student & Legal Affairs) is responsible for the enforcement of all policies.

## **VI. Student Discipline**

### **A. Misconduct** (Violations of the Code of Student Conduct, local, state, federal laws)

#### **1. Offenses against another person**

General Description: These violations relate to the intentional or unintentional harming of another person (not necessarily a student) and could have physical injuries or emotional impact on the other person(s).

Category I Examples: sexual assault, aggravated assault, robbery

Category II Examples: A&B, harassment, bullying

Category III Examples: fighting (mutual combat), assault, threats

#### **2. Offenses against property**

General Description: These violations relate to the improper use or taking of property belonging to another person and/or the College.

Category I Examples: breaking and entering, arson

Category II Examples: major theft (value > \$100), unauthorized use/entry

Category III Examples: minor theft (value < \$100), vandalism

#### **3. Offenses against health and safety**

General Description: These violations relate to issues that may - but do not necessarily - be criminal offenses off campus but the commission of which creates health and safety risks for the accused student, other people, or the College environment generally.

Category I Examples: weapons, explosives, drugs

Category II Examples: alcohol, infectious disease, misuse of fire safety equipment (including false alarms), unauthorized copying of keys

Category III Examples: smoking, candles, pets, vermin/infestation, trash

**4. Offenses against peace and order**

General Description: These violations relate to behaviors required for a peaceful, orderly campus community; they often reflect expectations students will find in the workplace and in the cities/towns in which they will live upon completing their educations.

*Category I Examples:* fraud, failure to comply with directions of College officials in the proper exercise of their duties

*Category II Examples:* false statement during an official investigation, failure to report violations of the Code of Student Conduct

*Category III Examples:* disorderly conduct, obstructing the free flow of traffic (vehicular or pedestrian)

**5. Offenses against Housing**

General Description: These violations relate to housing-specific issues that do not apply elsewhere on campus.

*Category I Examples:* None

*Category II Examples:* Repeat violations.

*Category III Examples:* First violations.

**B. Disciplinary Procedures**

1. **Reporting:** All violations (or suspected violations) shall be reported. Reports should be made in writing when possible/practical. Once reported, all violations (or suspected violations) will be documented.
2. **Initiation of Discipline\*:** Reports will be forwarded immediately to the appropriate Hearing Officer.
  - a. Student/non-resident violations (all) to the Dean of Student & Legal Affairs
  - b. Non-student violations to the Dean of Student & Legal Affairs
  - c. Student/resident Housing violations to Housing staff
    - (i) All Housing violations screened by Director of Residence Life
    - (ii) Reported violations distributed Area Coordinator, Director of Residence Life, or Dean of Student & Legal Affairs.  
 Area Coordinator = Category III violations (exception: probation violation where the probation was assigned by the Area Coordinator)  
 Director = Category II violations (exception: probation violation where the probation was assigned by the Director)  
 Dean of Student & Legal Affairs = Category I violations (exception: probation violation where the probation was assigned by the Dean)
  - d. When a reported violation involves violence, force, and/or a reasonable concern that a safety risk exists, the Dean of Student & Legal Affairs may request an Order of Immediate Interim Suspension from the College President. Such an Order requires that the accused student immediately leave College grounds (including housing) and may not return for any reason (including classes) without permission from the College President – typically when either the investigation is concluded or the safety risk no longer exists. Housing residents who are accused of conduct violations that necessitate their temporary removal from [only] housing (also for safety reasons) may be suspended by either the Director of Residence Life or the Dean of Student & Legal Affairs. These residents will be responsible for finding temporary accommodations and transportation to/from campus.

\*Sexual misconduct or sex discrimination matters will be assigned by the Title IX Coordinator.
3. **Notice:** Students accused of Code violations will be given written notice
  - a. Specific policy, regulation, rule, or law allegedly violated
  - b. Date (approximated, if necessary) of alleged violation
  - c. Hearing date, time, and location (not less than 24 hours) or directions for the accused student to schedule a hearing.

## **Section Eight: Code of Student Conduct**

- d. Notice shall either be sent by student email, certified mail to the accused student's address of record, OR hand-delivery with a signed receipt/acknowledgment by the accused student. Any student who refuses to claim his/her certified mail will be assessed the cost of the mailing.
- e. Additional Notice may be waived in limited circumstances.
  - (i) The accused student gives demonstrably false information during the investigation, and the original Notice contained a warning of consequences if false information is given.
  - (ii) Additional violations are discovered during the investigations, the violations are directly related to the original matter(s) being investigated, and the accused student agrees to proceed without initiating a second disciplinary process.

### **4. Investigation:** Assigned hearing officer conducts investigation\*

- a. Interview complainant/victim. The Hearing Officer shall ascertain whether, in fact, a violation is likely to have occurred. If there is no basis for the complaint, the matter will be dismissed immediately. False reports could trigger a new disciplinary proceeding against whoever made it.
- b. Interview witnesses; witness names may be provided by the complainant/victim, the accused student, other witnesses, College faculty/staff, and/or the hearing officer.
- c. Review incident or police report(s), if any.
- d. Review documentation or other records, recordings, videos, etc..
- e. Hearing with accused student.

\* These steps need not occur in any particular order. Interviews and hearings shall not conflict with any student's class schedule. In order to protect confidentiality and to promote candor, hearings and interviews shall be conducted in private; students may not be accompanied by parents, friends, roommates, attorneys, or other persons – except an Ombudsman.

### **5. Hearing:** Accused students are entitled to an impartial, closed hearing with the Hearing Officer who may be assisted by another College official to ensure accuracy. As stated below, the accused may be accompanied by an Ombudsman\*

- a. Students have the right to attend the hearing
  - (i) Failure to attend could result in decision without student's input
  - (ii) If a student is unable to attend a scheduled hearing for good cause or needs more time to prepare, s/he must contact the Hearing Officer to reschedule.
- b. Students have the right to answer and admit/deny the allegation
- c. Students have the right to decline to give a statement
  - (i) Students' failure to provide a statement will not end the process; decisions shall be made without the student's input.
- d. Students have the right to present fact or character witnesses.
- e. Students have the right to present relevant evidence
- f. Students do not have the right to an attorney during any disciplinary proceedings, as College proceedings are non-legal in nature and are, therefore, not subject to the same rules, procedures, and standards of proof as legal proceedings. (Exception by law: cases involving sexual misconduct or sex discrimination.)
- g. Students have the right to seek procedural assistance and information from the Ombudsman, a neutral third party who is a member of the College staff appointed by the President, who does not advocate for any position or outcome, but who is well-versed in the Code of Student Conduct. The Ombudsman may meet with accused students (as requested) to prepare for the hearing and may attend the hearing. (By law: Complainants and accused students in sexual misconduct & sex discrimination cases may be accompanied by an advisor to any proceeding. The advisor may not participate. The student must provide the name and title (if any) of the advisor no less than one business day in advance.)

\*These rights apply at all hearings, including the Committee on Student Conduct.

### **6. Deliberation:** The Hearing Officer shall take the necessary time to decide and shall re-interview any person s/he deems necessary. The standard to be applied in making decisions is preponderance of the evidence (i.e., it is more likely than not that the accused student committed the violation(s) as alleged).

7. **Decision:** The hearing officer shall notify the student in writing of the decision and the reasoning for that decision. It shall either be sent by certified mail to the appealing student's address of record or hand-delivered with a signed receipt/acknowledgement by the appealing student.
- Findings: Not responsible/not in violation OR Responsible/in violation
  - If found not responsible, report/file will be closed and nothing will be noted in the student's official disciplinary records
  - If found responsible, sanction(s) shall be imposed.
- \*By law, complainants in sexual misconduct & sex discrimination cases will receive notice of findings.
8. **Sanctions:** A response appropriate for the offense will be imposed.
- Censure: A written reprimand placed in the student's disciplinary file.
  - Fine: A financial penalty.
  - Educational Sanction: An exercise intended to help the student learn.
  - Probation: A period of time when the student's conduct will be more closely monitored for compliance with all rules, regulations, policies, and laws. Specific terms and/or conditions that are intended to ensure safety, to compensate any victim, to deter this or any student from a similar course of conduct, or to educate the student may be placed upon a student for whom the sanction is probation. Examples of terms/conditions that may be imposed include (but are not limited to) restitution, letters of apology, counseling, written assignments, educational sanctions, community service, restriction of activities, and no contact with designated persons. Failure to comply with any term/condition of probation could result in additional disciplinary action. The written decision will state when the probation period expires; that time may be extended for cause (e.g., the student's inability to complete probationary sanctions).
  - Suspension: A period of time when the student may not be present on campus (or at housing) for any reason without the prior, written permission of the Hearing Officer. The written decision will state when the suspension period expires. A student who is suspended and who comes onto campus (or housing) could be arrested and prosecuted for criminal trespassing and could face additional disciplinary action.
  - Dismissal: The student is terminated from the College for an indefinite period of time and may be readmitted only with written approval from the College President. A student who is dismissed and who comes onto campus (or housing) could be arrested and prosecuted for criminal trespassing and could face additional disciplinary action. Any Willowbrook Woods resident who is dismissed from the College is automatically expelled from housing.
  - Expulsion (Willowbrook Woods residents only): The resident is removed from housing for a specific period of time, typically for the remainder of the contract term. The resident must remove all personal possession from his/her apartment, complete a formal check-out with the Area Coordinator, relinquish all keys and housing ID, and vacate the premises as directed. A resident who is expelled and who comes onto housing property could be arrested and prosecuted for criminal trespassing and could face additional disciplinary action. As stated in the housing contract, expulsion does not release the now-former resident from his/her financial obligations under the contract; fees will remain due as agreed unless and until that person's *vacancy* – **not room** – is filled.
9. **Appeal:** Any student who has been found responsible/in violation of the Code of Student Conduct and sanctioned may petition to appeal that decision (or any part thereof) to the next higher authority within the Code of Student Conduct. **The appeal must be in writing, must state with specificity the grounds for appeal (i.e., why the decision was incorrect), and must be submitted to the Hearing Officer within 15 calendar days of the date of the decision being appealed.** The Hearing Officer will promptly notify the proper official and forward the appeal, a copy of the student's file, and any response to the petition to appeal. (By law, any appeal process available to accused students in sexual misconduct or sex discrimination case must also be available to complainants.)

\*See B5 (above) for list of appealing student's rights.

## **Section Eight: Code of Student Conduct**

- a. Decisions by the Area Coordinator (housing only) are appealed to the Director of Residence Life.
- b. Decisions by the Director of Residence Life (housing only) are appealed to the Dean of Student & Legal Affairs.
- c. Decisions by the Dean of Student & Legal Affairs are appealed to the Committee on Student Conduct. The Committee Chair functions as the designated “Hearing Officer” for purposes of this provision.
  - (i) The Committee on Student Conduct is comprised of eight members: three members of the full-time faculty (selected by the Chairman of the Faculty Senate), no more than five students (selected, after completing an application, by the Committee Chairs), and two Chairs (selected by the President).
  - (ii) When an appeal is noted, all three faculty members and three students will be contacted to serve at the hearing. The two Chairs will alternate hearings. At least one Chair and three members must be present (to constitute a quorum).
- d. Decisions by the Committee on Student Conduct are appealed to the President of the College. Decisions by the President are final.

**10. Appeal Procedures:** Upon receiving the student’s appeal letter and copy of the file, the Appeal Official will promptly review the petition for appeal and the file materials submitted by the Hearing Officer to determine student’s petition meets the required appeal criteria:

- Petition is in writing.
- Petition is timely filed.
- Petition states what is being appealed (e.g., finding and/or sanction).
- Petition clearly states the student’s grounds for appeal (i.e., merely being dissatisfied with the outcome is insufficient). Acceptable grounds include the discovery of new evidence, proof of actual innocence that was unavailable before the Decision was made, or misconduct by the Hearing Officer. Such allegations must be supported by reference to specific evidence (such as notarized statements by newly identified witnesses, documentation, etc.) – not by vague claims or assertions.
- All procedural requirements for Hearings were met (e.g., notice, opportunity to be heard, etc.)
- Student participated as requested at the Hearing from which the decision is being appealed (i.e., Documented failure to cooperate with the investigation and/or hearing forfeits the student’s right to appeal the decision. An accused student must attend his/her hearing even if s/he exercises the right to decline or give a statement or to answer questions.)

If the criteria have not been met, the Appeal Officer will notify the student that his/her appeal has been rejected. If the criteria have been met, the Appeal Officer will promptly schedule a hearing. When possible, hearings will be scheduled within 15 calendar days but should be scheduled for the soonest available date.

- a. Appeals to the Director of Residence Life will consist of a review of the file, additional interviews as necessary, and a hearing with the appealing resident. The Director of Residence Life should examine whether the appealing student has compelling grounds for the appeal and may uphold the decision, reverse the decision, or modify the decision as s/he deems appropriate. The new decision will be issued in writing within 15 calendar days and either sent to the appealing student by certified mail to the appealing student’s address of record or hand-delivered with a signed receipt/acknowledgement by the appealing student.
- b. Appeals to the Dean of Student & Legal Affairs will consist of a review of the file, additional interviews as necessary, and a hearing with the appealing resident. The Dean of Student & Legal Affairs should examine whether the appealing student has compelling grounds for the appeal and may uphold the decision, reverse the decision, or modify the decision as s/he deems appropriate. The new decision will be issued in writing within 15 calendar days and either sent to the appealing student by certified mail to the appealing student’s address of record or hand-delivered with a signed receipt/acknowledgement by the appealing student.

- c. Appeals to the Committee on Student Conduct are more complex.
- (i) Scheduling: At the beginning of each semester, the Chairs of the Committee will record when members of the Committee are available by consulting the faculty grid and the required applications submitted by student representatives. This information will be provided to the Ombudsman for efficient scheduling. The Ombudsman will notify the appealing student as well as the Committee members of the date, time, and location of the hearing in writing. The Ombudsman may meet with the appealing student prior to the appeal hearing to discuss hearing procedures (if requested by the appealing student) and shall attend the hearing to answer the appealing student's procedural questions during the hearing and to make recommendations to the Committee Chair when disputed issues arise during the hearing.
  - (ii) The Committee Chair will preside over the appeal hearing, resolve any procedural disputes, ensure that the hearing is fair, participate in deliberations, and write the Committee's decision. The other Committee members will hear the evidence and deliberate.
  - (iii) Hearings by the Committee on Student Conduct shall be recorded, and the tape(s) shall be kept with the file by the Chairs in a designated, secure location. No other person may record these proceedings. Additionally, hearings are closed; only the Committee, the appealing student, the Ombudsman, the Dean, and his/her investigatory aide may be present during the hearing.
  - (iv) The Dean will address the Committee first, followed by the appealing student. Then, each side may present a summary of his/her position or present witnesses/documents to support his/her position.
  - (v) Witnesses will remain outside the hearing until called; the Ombudsman will assist in bringing witnesses into the hearing. When possible, witnesses will be seated in an area separate from the Dean and the appealing student. All witnesses (including the Dean and the appealing student) may be questioned by the Dean, the appealing student, and/or any member of the Committee; such questioning should be conducted in logical sequence. Either side may present documentary evidence, as well.
  - (vi) Evidentiary rules of court do not apply; however, standard practices of civility apply. No party should interrupt a person who is speaking unless s/he has a valid objection. No party should insult, attack, harass, or intimidate any other person. All parties should remain in their seats unless a demonstration requires otherwise. Anyone who fails to follow these practices may be removed from the hearing and a decision may be made without his/her additional input.
  - (vii) At the conclusion of summaries and/or testimony, the Dean may provide closing remarks, followed by the appealing student. Following the closing remarks, the hearing is concluded.
  - (viii) Only the Committee members may be present during deliberations. A majority vote dictates the Committee's decision. The Committee should examine whether the appealing student has compelling grounds for the appeal and may uphold the decision, reverse the decision, or modify the decision as it deems appropriate.
  - (ix) The Committee Chair will issue a written decision to the appealing student, copied to the Dean, within fifteen calendar days. This decision may be sent by certified mail to the appealing student's address of record or hand-delivered with a signed receipt/acknowledgement by the appealing student. The decision will not become public; rather it will be placed in the appealing student's official disciplinary file and subject to the usual FERPA requirements.



***Section Eight: Code of Student Conduct***

- d. Appeals to the President will consist of a review of the file, additional interviews as necessary, and a hearing with the appealing student. The President should examine whether the appealing student has compelling grounds for the appeal and may uphold the decision, reverse the decision, or modify the decision as s/he deems appropriate. The new decision will be issued in writing within 15 calendar days and either sent to the appealing student by certified mail to the appealing student's address of record or hand-delivered with a signed receipt/acknowledgement by the appealing student. Decisions by the President are final.



## SECTION NINE: FERPA

### I. The Family Educational Rights and Privacy Act (FERPA) Policy

(The following policy is applicable to all Allegany College of Maryland faculty and staff)

The Family Educational Rights and Privacy Act (FERPA) is a Federal law that protects the privacy of student educational records. The law applies to all schools that receive funds from the U.S. Department of Education.

As implied by the title, FERPA requires schools to protect the **privacy** and **access** rights of students regarding their educational records. There are limitations on what information a school may disclose and mandates on when students may inspect, review, and seek to amend their own records.

Since many FERPA terms are broad in nature and can be subject to interpretation, the President's Staff, with input from faculty and staff, has defined these terms as they will pertain to Allegany College of Maryland, and has identified and addressed how all college faculty and staff should respond in certain situations.

#### INSTITUTIONAL DEFINITIONS

Directory information – Directory information is information that **can be** disclosed about a student and includes the following: student name, address, field of study, degree/awards, and full-or part-time status. Address will only be disclosed when circumstances warrant it. This policy adds address to “directory information”. (NOTE: The fact that this information **can be disclosed** does **not require** the College to do so.)

Educational record – Education records are all records that are directly related to a student and are maintained by an educational agency, an institution, or a party acting for the agency or institution.

Emergency – Emergency is any incident that poses a health risk or threat of imminent danger, physical violence, or intimidation.

Enrolled student – A student is considered to be “enrolled” once the student has processed the registration forms and the schedule is either provided to the student or made available to him/her online. While *applicant* information is not protected by FERPA, the College will not release it without proper authority.

#### DESIGNATED INSTITUTIONAL CONTACTS

FERPA questions should be directed to the Director of Admissions and Registration. If s/he is unavailable, the Associate Registrar should be the contact. In Pennsylvania, the Coordinator of Academic Services is the contact for both campuses. If necessary, the Dean of Student & Legal Affairs may be consulted for responses to legal questions.

The Student Services Appeals Committee will hear student complaints and petitions to amend educational records.

## **DISCLOSURE OF STUDENT INFORMATION**

Educational records are “owned” by the student when he/she turns 18 **or** enrolls in college. However, grades may be disclosed to parents of dependent students only after written verification of dependency status has been obtained from the parents; i.e., copy of the 1040 federal tax return or signed release form obtained from the Admissions/ Registration Office.

When an inquiry about a student is made by a faculty/staff member, the person who has the information should disclose that information only after assessing the request and determining its legitimacy as a “need to know.” The “holder” of the information will make that determination.

Student information should not be disclosed over the phone to the students’ family members or others, since one cannot be sure with whom he/she is actually speaking.

## **MAINTENANCE OF STUDENT RECORDS**

Grades, rosters, and disciplinary records are kept indefinitely. All other centralized institutional records should be kept for five (5) years. Individual departments should establish their own policies for the length of time students records are to be kept.

## **ALUMNI**

Educational records of alumni are subject to FERPA regulations. Anything that occurs after graduation is considered directory information and, thus, not covered under FERPA.

## **EMERGENCY SITUATIONS and/or DISCLOSURE OF INFORMATION TO LAW ENFORCEMENT**

Information regarding health/safety emergencies may be disclosed without consent, with *emergency* being defined as stated above.

In the event of an on-campus emergency,\* the College may call the emergency contact, as this information is provided at registration time.

\*Or emergency that occurs off-campus during/associated with a college-sponsored activity.

If a crime or threatening situation occurs on campus, (eg., fight or breaking and entering) *and* a College employee calls the authorities or agrees with a non-employee’s decision to call the authorities, then the College will provide requested information to the police. Requests for information will be honored within 24-hours of the call. If the investigation is on-going, requiring longer than a 24-hour period, then the concern is not as urgent, and the College will not release student information without a properly issued subpoena or court order.

If a law officer comes to the campus to locate a student, the officer must present a subpoena to the Director of Admissions/Registration or designee, **if** the incident for which he is seeking the student occurred off-campus and/or **is not** an emergency to us (see *emergency* definition above).

Approved 3/06

## **POLICY STATEMENT ON THE RELEASE AND CONFIDENTIALITY OF STUDENT RECORDS**

Allegany College of Maryland affirms that a student’s official educational records are confidential matters. The College adheres to the Family Educational Rights and Privacy Act regarding inspection, release or disclosure, and providing an opportunity to correct entries. The College’s Policy is set forth in full in the Academic Information

section of the annual catalog, and students are encouraged to familiarize themselves with all aspects of their privacy rights and responsibilities. In brief, the Family Educational Rights and Privacy Act and the College Policy provide students the right to:

- Inspect and obtain copies of information contained in their education records.
- Prevent disclosure of “directory information,” such as name, address, major field of study, etc.
- Have educational records treated as confidential.
- Challenge the contents of educational records.
- File complaints with the U.S. Department of Education concerning alleged failures of Allegany College of Maryland to comply with the law.
- Obtain a copy from the Allegany College of Maryland’s Registration Office.

### **Procedures for Students to Review Their Academic Record**

Any student of Allegany College of Maryland who wishes to review their academic record may do so according to the following procedure:

Step 1 - Obtain the “Request to Review Permanent File” available from the Registration Office.

Step 2 - Complete the form indicating the specific materials to be reviewed and return the completed form to the Registration Office.

Step 3 - Once the request is filed, the student will be notified in writing within thirty (30) days of a time and date the file may be reviewed.

Step 4 - The student will review the file with the Director of Admissions & Registration.

It should be noted that students may obtain a student copy of their transcript at any time by filing a request with the Registration Office.

As of January 3, 2012, the U.S. Department of Education’s FERPA regulations expand the circumstances under which your education records and personally identifiable information (PII) contained in such records - including your Social Security Number, grades, or other private information - may be accessed without your consent. First, the U.S. Comptroller General, the U.S. Attorney General, the U.S. Secretary of Education, or state and local education authorities (“Federal and State Authorities”) may allow access to your records and PII without your consent to any third party designated by a Federal or State authority to evaluate a federal--or state supported education program. The evaluation may relate to any program that is “principally engaged in the provision of education,” such as early childhood education and job training, as well as any program that is administered by an education agency or institution. Second, Federal and State Authorities may allow access to your education records and PII without your consent to researchers performing certain types of studies, in certain cases even when we object to or do not request such research. Federal and State Authorities must obtain certain use-restriction and data security promises from the entities that they authorize to receive your PII, but the Authorities need not maintain direct control over such entities. In addition, in connection with Statewide Longitudinal Data Systems, State Authorities may collect, compile, permanently retain, and share without your consent PII from your education records, and they may track your participation in education and other programs by linking such PII to other personal information about you that they obtain from other Federal or State data sources, including workforce development, unemployment insurance, child welfare, juvenile justice, military service, and migrant student records systems.



## **SECTION TEN: COMMON QUESTIONS ABOUT ACM**

### **Questions Relating to Academics**

1. What does it mean to be a full time student?

Students are considered to be "full time" if they enroll in twelve or more credit hours a semester. (Section N of the Academic Regulations.) Students taking fewer than 12 credit hours in a semester are classified as "part time." Full time classification may be important for various types of insurance for students who are financially dependent upon parents or others.

2. What is a credit hour?

The credit hour is an academic unit of measure to determine the relative value and difficulty of different courses, and is determined on the basis of how much time a student spends in class. For lecture courses, each credit hour means a student will spend 50 minutes per week in class during a 15-week semester. Laboratory, clinic, and physical education courses are based upon a different calculation.

For example, if you are enrolled in a three-credit hour, lecture course, you will spend 150 minutes or 2.5 hours per week in the class for a 15-week semester.

3. What is a program of study?

A program of study (sometimes called a major) is a program of study leading to a degree or certificate. Completion of the courses in a particular program of study is one of the requirements for graduation. The College Catalog lists various programs of study in different majors or areas of emphasis consisting of specific courses and electives.

4. How much time must I spend for a course in addition to time spent in the classroom (homework, class preparation, etc.)?

Study skills experts advise students should spend at least 2 hours in outside work for every hour spent in the classroom. Therefore, students enrolled in 12 credit hours will be spending 24 hours in study outside the classroom for their courses. However, it is important to realize that courses vary in both the degree of difficulty and the policies of the instructor.

5. Does the College have an attendance policy?

Yes. The attendance policy is found at Section U of the Academic Regulations. Individual instructors may vary from the general expectation that students attend every class session except in cases of emergency. Instructors may drop or withdraw a student from a course when they believe that student cannot successfully complete the course in the time remaining.

6. How do I interpret my grade report?

The meaning of letter grades received in both mid-semester and final grade reports can be found in Section H of the Academic Regulations.

7. What grades are assigned if I stop coming to classes during a semester or summer term?  
 Nonattendance may result in “F” grades being recorded in any or all courses in which the student is enrolled. Under certain circumstances, “F” grades can be avoided by following withdrawal procedures set forth in Section R of the Academic Regulations. Students are encouraged to follow withdrawal procedures to avoid the academic penalty of “F” grades should the student resume an educational program.

8. What is a quality point on my grade report?  
 At the end of each semester or summer term, you will be given a letter grade by your instructor for each course in which you’re enrolled. Each letter grade is worth so many “quality points” per semester hour. The quality points assigned for letter grades are explained in Section H of the Academic Regulations.

Since “A” work is of higher quality than “B” through “F” work, the “A” carries more quality points. Each quality point value is multiplied by the credit hours for the course. Example: Attaining a “C” in English 101, a three-credit course, earns two quality points per credit hour, or a total of six quality points for the class.

9. How do I compute my semester quality point average?  
 Academic performance for a semester or term is expressed as quality point average or grade point average. The semester or term quality point average (QPA) will be computed by the College and will appear on your grade report and transcript. In general, it is calculated by determining the quality points for each course (quality points earned via the grade assigned by the instructor times the number of credit hours of the course); adding the quality points for each course and then dividing by the number of credit hours taken during that semester or term. Complete information about quality point averages can be found in Section J of the Academic Regulations. An example calculation for a 17 credit hour semester follows:

	Semester Hours	Grade	Quality Points of Grade	# of Quality Points per Course <i>(col. 1 x col. 3)</i>
English	3	A	4	12
History 103	3	F	0	0
Automotive Technology 101	4	B	3	12
Automotive Technology 102	4	C	2	8
Physical Education 105	1	D	1	1
Automotive Technology 105	2	A	4	8
<b>TOTAL</b>	<b>17</b>			<b>41</b>

Compute the semester quality point average by dividing the total number of quality points for all courses by the total number of semester hours. Therefore, in the example above:

Semester quality point average  $\frac{41}{17}$   
 $17 = 2.4117$  or 2.41 (to the nearest hundredth)

## **Section Ten: Common Questions About ACM**

### 10. What is the difference between semester quality point average and cumulative quality point average?

At the end of each semester or term, your grade report will show two types of quality point or grade point averages: the semester quality point average and the cumulative grade point average. If this is your first semester at Allegany College of Maryland, the semester and cumulative quality point average will be the same.

A semester quality point average, or grade point average, is the total number of quality points earned in a semester divided by the total of credit hours attempted.

A cumulative quality point average is the total number of quality points earned in all semesters or terms attended divided by the total number of credit hours attempted in all semesters or terms of attendance.

### 11. What academic honors and programs exist for outstanding students?

Allegany College of Maryland recognizes high academic performance in a given semester by the designation of Dean's List and Honors List. Explained in Section J of the Academic Regulations, these designations are determined by the quality point or grade point average for each semester.

The College also recognizes high academic performance upon graduation with a degree or certificate with designations of summa cum laude; magna cum laude, and cum laude. The grade point average qualification for each of these designations is explained in Section G of the Academic Regulations.

The College has an Honors Program for students who have demonstrated outstanding academic achievement. Honors courses, seminars, field trips, conferences and other special activities are offered, and certain fees are waived for Honors Program participants. Applicants must have a 3.50 cumulative high school grade point average (on a four point scale) or a 3.25 cumulative grade point average in at least 12 credit hours of college courses. Both part-time and full-time students are eligible.

Students completing 12 credit hours in a degree program with a 3.50 cumulative grade point average are eligible for membership in Allegany College of Maryland's chapter of Phi Theta Kappa, national honor society.

### 12. When is a student placed on academic probation or suspended academically?

Students are expected to maintain a quality point or grade point average that will indicate a level of achievement that qualifies them for graduation when other requirements are met. Sections K, L, and M of the Academic Regulations explain the conditions for being placed on academic probation or suspension for poor scholarship and the consequences of each.

### 13. What is a prerequisite?

A prerequisite is a course which is basic to others which follow in a given discipline or department. A course for which there is a prerequisite cannot be taken until the prerequisite is satisfactorily completed.

Example: General Biology I is a "prerequisite" for General Biology II, and a student cannot enroll in General Biology II without having passed General Biology I.

Prerequisites are designated in the course descriptions of the College Catalog. Be sure to check the Catalog before putting together a schedule of classes.

14. What is an elective?

The designation of “elective” in a curriculum means that the student may make a choice. If the curriculum or major lists just the word “elective,” it means that the student may select any course or courses which equal the required number of credit hours. If the curriculum or major lists the word “elective” followed by a designation such as social science, humanities, natural science, or other restriction, the choice is limited to courses fitting the designation.

Lists of courses which will satisfy restrictions such as arts and humanities, mathematics and biological/physical sciences, physical activities, English composition, social and behavioral sciences, and interdisciplinary and emerging issues may be found in the College catalog.

15. What are the minimum requirements for graduation?

Students who complete the course requirements set forth in a curriculum or major may be eligible for graduation. (The College also offers letters of recognition.) But, eligibility for graduation entails more than mere completion of a list of courses in a curriculum or major. Even an overdue library book with an unpaid fine can keep a student from graduating. A complete listing of graduation requirements can be found in Section F of the Academic Regulations. Regulation F4 explains the graduation application process.

16. What is the role of an academic advisor?

Allegany College of Maryland has a program of academic advising designed to ensure that the student is aware of the comprehensive educational opportunities offered, and that they acquire the knowledge and skills needed for continued studies or entry into a career field. Students are assigned an academic advisor who is familiar with the academic information necessary for that student to successfully reach educational goals.

Allegany College of Maryland plays a critical role in raising higher education levels in the tri-state area and offers expanded efforts to guide students toward their academic goals. With the award of a U.S. Department of Education-supported grant, funded through its Strengthening Institutions Program, the College's Advising Center offers enhanced academic advising services to students to boost their chances for success by consolidating academic advising services in one location for greater access and more consistent delivery. The Advising Center allows the College to take a systematic approach to advising through additional personnel and improved facilities. This one-stop advising services center located in the College Center includes a wide range of academic advising, career planning, supportive counseling, educational coaching and mentoring services.

Though students remain ultimately responsible for meeting graduation requirements, students are encouraged to consult with their academic advisor as part of the registration process for each semester or term.

Academic advisors can also provide information about College resources and programs and career fields and can answer general questions about College policies and protocols.

17. What do I do if an instructor does not show up for class?

If an instructor does not appear in class within ten minutes after the scheduled starting time, a member of the class should go to the instructor's office. If the instructor is not in his/her office, a student should go to Senior Vice President of Instruction and Student Affairs' Office on the main campus or to the Student Services Office on either of the Pennsylvania campuses. If the instructor cannot be located by these methods, students may consider the class cancelled.

18. Do I need to let the College know if I change my address or phone number?

Yes. Students should take immediate steps to notify the Registration Office at any campus of changes in local or permanent address changes, telephone number changes, and e-mail address changes. The College's registration data system is used by instructors to contact students and by various administrative units of the College for mail, including grade and other academic reports.



## **Questions Relating to Student Life**

19. Is there health insurance available to students?

Yes. The Business Office selects a health insurance program designed especially for College students who need major medical coverage. Complete details are provided in a brochure available from the Cashier's desk at any campus of the College. Students who desire to participate make arrangements directly with the insurance provider.

20. Where can students access health care in Cumberland?

The Office of Student & Legal Affairs maintains a list of local medical providers, including hospitals, clinics, and more.

The emergency telephone number for any injury or illness requiring ambulance assistance from any Allegany College of Maryland campus is 911. (See also Student Counseling Services listed in this Handbook.)

21. What services are available to students from the Dental Hygiene Department?

Low cost dental hygiene care is available for Allegany College of Maryland students at the main campus dental hygiene clinic. The cost is \$5.00 with a current College ID card. Dental hygiene students perform the services, directly supervised by licensed dentists and dental hygiene instructors. Services include medical and dental history, oral inspection to include cancer screening, blood pressure evaluation, cleaning of teeth, fluoride therapy, and individualized instruction on self-care of teeth and gums and nutrition, and dental X-rays. All students are encouraged to utilize this service.

Appointments are necessary. Contact the Dental Hygiene Department in the Allied Health Building at 301-784-5540.

22. How do I obtain a locker on the main campus?

Student lockers are located in three buildings on the main campus: College Center, Humanities, and Science. Students should inquire at the Office of Student Life in the College Center Building (CC-160).

Lockers are reassigned during the fall semester of each year on a first-come, first-serve basis. Returning students may request the same locker for a second year by notifying the Office of Student Life at the end of the spring semester. There is no charge for lockers.

At the end of the Spring semester, please remove all of your belongings and your lock from the locker. All lockers will be completely emptied prior to the start of each fall semester. Items left in the locker as of the end of the summer semester will be discarded. ACM assumes no responsibility for personal property or identifying information abandoned in the locker.

23. Can students cash personal checks on campus?

Yes. Students may write a personal check for up to \$15.00, and have it cashed at a cashier's desk at the main campus only. Two-party checks are not accepted. Personal checks are not accepted during the last month of any semester, or during summer term.

Students should note there is a fee for all dishonored ("bad") checks.

24. Is there public transportation available for the main campus?

The Allegany County Transit Authority (ATA) provides bus service to the main campus Monday through Friday. Schedules are available in the Student & Legal Affairs Office (C-152) or by calling the ATA at 301-722-6360. Passes can be purchased in the Bookstore. See page 38 of this Student Handbook for detailed information.

Several taxi companies serve the greater Cumberland area and these can be contacted by telephone.

25. Are childcare services available to main campus students?

Yes. Please see the information on the main campus Campus Kids Child Care Center on page 36 of this Handbook.

26. How can I keep informed about the College after I graduate or transfer?

The Allegany College of Maryland Alumni Association strives to stimulate alumni interest, involvement and participation in the programs and activities of the College. Membership in the Alumni Association is open to all students who have completed one credit or non-credit class, as well as graduates. The business of the Association is managed by a Board of Directors and they meet regularly throughout the year. The annual business meeting of the Association is open to all members.

27. What services are available to students from the Massage Therapy Program?

All students are eligible to receive a one-hour massage per semester from the therapeutic massage student clinic. The cost is \$10. The massage therapy students offer relaxing Swedish massage, deep tissue massage, myofascial release work, as well as Reiki. Modalities vary depending on the semester. Appointments are necessary. Contact the Massage Therapy student clinic in the Allied Health Building in room AH 154A or by phone at 301-784-5598. Students are encouraged to utilize this service.

28. What services are available to non-traditional students?

Non-traditional students are encouraged to contact Wilma Kerns at 301-784-5234.

29. What do I do if I witness an assault or crime?

Call 911. Then call Campus Security at (301) 784-5555.

30. What do I do if I am the victim of sexual misconduct or sex discrimination?

Call 911 for immediate help by police and/or ambulance. then call Campus Security at (301) 784-5555. If you do not want to take these steps, please get help and tell someone you trust. ACM's Title IX Coordinator will be happy to help you. Detailed information is available online at [www.allegany.edu/titleIX](http://www.allegany.edu/titleIX).



## SECTION ELEVEN: NAVIGATING ACM

### I. Directories

#### A. Directory of Student Services Personnel

<u>Service</u>	<u>Contact Person/Title/College Location</u>
Student & Legal Affairs .....	Dr. B. Renee Conner Dean of Student & Legal Affairs College Center Bldg. (CC-152) 301-784-5206
General College Information .....	Information Center Continuing Education Building 301-784-5005
Admissions .....	Ms. Cathy Nolan Director of Admissions and Registration College Center Bldg. (CC-127) 301-784-5199
Athletics .....	Steve Bazarnic Director of Health, PE, & Athletics Gymnasium (G-166) 301-784-5265
(Open Gym, Wellness Center, Pool, Teams, Intramurals)	
Bookstore .....	Ms. Breann D'Atri Bookstore Manager College Campus Store 301-784-5349
Business Office.....	Ms. Terri Smith Business Office Manager College Center Bldg. 301-784-5226
Cafeteria.....	Sherry Buffenmyer Finance College Center Bldg. (CC-177) 301-784-5225

<u>Service</u>	<u>Contact Person/Title/College Location</u>
Career Advising .....	Ms. Danielle Foote Student Success Center Humanities Bldg. (H-58C) 301-784-5235
Career Exploration - Bedford County Campus .....	Ms. Mary Ann Clark Coordinator of Student & Career Services 814-652-9528, ext 6204
Career Exploration - Somerset County Campus .....	Ms. Brianna Livingston Director of Student Services 814-445-9848, ext 6131
Center for Diversity & Student Engagement .....	College Center Building (CC-150) Contact Erin Yokum Director of Student Life College Center Building (CC-160) 301-784-5205
Child Care (Campus Kids).....	Ms. Michelle Merrill Child Care Center Manager Old Willowbrook Road 301-784-5236
Counseling Program (MD Campus Students) .....	Student & Legal Affairs College Center Bldg. (CC-152)  <b>Appalachian Behavioral Health Center</b> 301-724-7277  <b>WMHS Behavioral Health Services</b> 240-964-8585
Counseling Program (PA Campus Students) .....	Contact Student Services Office for referral Bedford - Somerset MH/MR
Disability Services .....	Ms. Wilma Kerns Advocate for Non-Traditional Students Humanities Building (H-150) 301-784-5234
Financial Aid .....	Ms. Vicki Smith Director of Student Financial Aid College Center Bldg. (CC-133) 301-784-5213
Foundation (Cumberland Campus) .....	Mr. David R. Jones Vice President of Advancement and Community Relations and Executive Director of the Foundation 301-784-5200
Foundation (Bedford County Campus) .....	Ms. Leah Pepple Director of PA Advancement and Community Relations 814-652-9528, ext. 6223

**Section Eleven: Navigating ACM**

<u>Service</u>	<u>Contact Person/Title/College Location</u>
Foundation (Somerset County Campus) .....	Ms. Brianna Livingston Contact Person 814-445-9848, ext. 6131
Graduation .....	Ms. Marianne Shedlock Associate Registrar Registration Office College Center Bldg. (CC-145) 301-784-5203
Health Programs.....	Ms. Mary Y. Hartman Coordinator of Admissions Counseling & Academic Advising College Center Bldg. (CC-126) 301-784-5204
Library .....	Ms. Barbara Browning Interim Director of Learning Resources Library Building 301-784-5268  Ms. Andrea Sleek Librarian for PA Campuses 814-445-9848, ext. 6118
Non-Traditional Student Services .....	Ms. Wilma Kerns Advocate for Non-Traditional Students Humanities Building (H-150) 301-784-5234
Pathways For Success (TRIO/SSS) .....	Ms. Deann Greenawalt Director Humanities Bldg. (H-57) 301-784-5630  Ms. Laurie Garris Advisement Counselor Humanities Bldg. (H-57) 301-784-5630  Mr. Matt Stucky Professional Math Tutor Humanities Bldg. (H-57) 301-784-5630
Pathways For Success (TRIO/SSS) .....	Ms. Deann Greenawalt Director Humanities Bldg. (H-57) 301-784-5630
Photo IDs .....	Ms. Erin Yokum Director of Student Life College Center Building (CC-160) 301-784-5205

<u>Service</u>	<u>Contact Person/Title/College Location</u>
Public Relations .....	Ms. Shauna McQuade Director of Public Relations and Marketing Advancement Office 301-784-5154
Registration/Records .....	Ms. Lisa Wilson Records Manager Registration Office College Center Bldg. (CC-146) 301-784-5345
Residency Change .....	Barbara Cantafio Office of Student & Legal Affairs College Center Bldg. (CC-152) 301-784-5206
Security .....	Mr. John Morley Coordinator of Security College Center Bldg. (CC-169) 301-784-5555
Student Housing.....	Mr. Gerry Geil Director of Residence Life 301-784-5638 (Willowbrook Woods Club House)  Ms. Megan Rowan Area Coordinator for Student Housing College Center Bldg. (CC-155) 301-784-5368  Barbara Cantafio Student Affairs Business Manager College Center Bldg. (CC-152) 301-784-5206
Student Life .....	Ms. Erin Yokum Director of Student Life College Center Bldg. (CC-160) 301-784-5205
Student Government & Clubs .....	Ms. Erin Yokum Director of Student Life College Center Bldg. (CC-160) 301-784-5205
Student Lockers .....	Ms. Erin Yokum Director of Student Life College Center Bldg. (CC-160) 301-784-5205
Student Service Appeals .....	Office of Student & Legal Affairs College Center Bldg. (CC-152) 301-784-5206

**Section Eleven: Navigating ACM**

<u>Service</u>	<u>Contact Person/Title/College Location</u>
Student Services (Bedford County Campus) .....	Ms. Robin Swindell Director of the Bedford County Campus and Student Services 814-652-9528, ext. 6202
Student Services (Somerset County Campus) .....	Ms. Deb Hoover Director of the Somerset County Campus and Student Services 814-445-9848, ext. 6106
Student Success Center.....	Mr. William Devlin Director of Student Success Center Humanities Bldg. (H-58B) 301-784-5551
Testing Services (Cumberland Campus) .....	Ms. Danielle Foote Coordinator of Testing Services Humanities Bldg. (H-58C) 301-784-5235
Transfer Advising (Cumberland Campus) .....	Mr. William Devlin Director of Student Success Center Humanities Bldg. (H-58B) 301-784-5551
Tutoring (Cumberland Campus) .....	Mr. William Devlin Director of Student Success Center Humanities Bldg. (H-58B) 301-784-5551
Vending .....	Ms. Charlotte Lapp Vending Manager College Center Bldg. 301-784-5175
Veterans Affairs .....	Mr. Ron Platt Veteran’s Coordinator Registration Office College Center Bldg. (CC-127) 301-784-5203

**B. Directory of Instructional Department Heads**

<b><u>Person</u></b>	<b><u>Title and College Location</u></b>
Dr. Kurt Hoffman .....	Interim Senior Vice President of Instruction and Student Affairs Humanities Bldg. (H-1) 301-784-5288
Mr. Steven Bazarnic .....	Director, Division of Physical Education Physical Education Bldg. (G-166) 301-784-5264
Mr. John Bone .....	Coordinator, Multimedia Technology Technology Bldg. (T-27B) 301-784-5635
Dr. June Bracken .....	Director, Developmental Education/Disabilities Humanities Building (H-48) 301-784-5112
Ms. Maureen Brown .....	Director, Teacher Education Humanities Bldg. (H-8) 301-784-5362
Ms. Barbara Browning .....	Interim Director, Learning Resources Library Bldg. 301-784-5268
Ms. Debbie Costello .....	Director, Nursing Programs/Legal Nurse Allied Health Bldg. (A-218) 301-784-5574
Ms. Pam Deering .....	Director, Instructional Technologies and Multimedia Services Technology Bldg. (T-28) 301-784-5314
Ms. Debra Frank.....	Director, School of Hospitality, Tourism, and Culinary Arts/Gateway Center 112 Baltimore Street, Cumberland, Maryland 301-784-5411
Ms. Jenna Gallion.....	Chair, Division of Humanities Humanities Bldg. (H-39) 301-784-5239
Ms. Cheryl Gilton .....	Director, Allied Health Technical Programs Technology Bldg. (T-135) 301-784-5615
Dr. Stephen Gibson .....	Interim Chair, Behavior and Social Sciences Humanities Bldg. (H-22) 301-784-5208



**Section Eleven: Navigating ACM**

<b><u>Person</u></b>	<b><u>Title and College Location</u></b>
Mr. Brandon Hoover .....	Coordinator, Political Science/Paralegal Humanities Building (H-17) 301-784-5300
Mr. Brandon Hoover .....	Coordinator, Criminal Justice Humanities Building (H-17) 301-784-5300
Ms. Peggy Hughes .....	Director, Office Technologies/Medical Assistant Program/Technology Bldg. (T-124) 301-784-5319
Mr. Ray Hunt .....	Director, Automotive Technology Program Automotive Tech. Bldg. (A-10) 301-784-5150
Ms. Robin Imgrund.....	Coordinator, Business Administration, PA Campuses Bedford County Campus 814-652-9528, ext. 6209 Somerset County Campus 814-445-9848, ext. 6112
Mr. John Jastrzembski.....	Chair, Division of Forestry and Science Science Bldg. (S-51) 301-784-5309
Ms. Paula K. Jilanis.....	Director, Massage Therapy Allied Health Bldg. (AH-124) 301-784-5191
Ms. Cathy Kline .....	Director, Radiologic Technology Allied Health Bldg. (AH-224) 301-784-5560
Mr. Ron Krug .....	Coordinator, Business Administration, Cumberland Campus Technologies Building (T-134) 301-784-5123
Mr. Joshua Leibfreid .....	Coordinator, Golf Management Physical Education Bldg. (G-170) 301-784-5274
Ms. Janet Murray .....	Coordinator, Instructional Technologies Technologies Building (T-28) 301-784-5376
Mr. Steve Resh .....	Coordinator, Forestry Programs Technology Bldg. (T-127) 301-784-5307

<b><u>Person</u></b>	<b><u>Title and College Location</u></b>
Dr. William Rocks .....	Director, Respiratory Therapist Program Facilitator, Institute for Leadership Development Allied Health Bldg. (A-105) 301-784-5522
Ms. Stacey Rohrbaugh .....	Director, Medical Laboratory Technology - Biotechnology Program Allied Health Bldg. (AH-249) 301-784-5547
Mr. David Sanford .....	Coordinator, Culinary Arts Director of Food Services/Gateway Center 112 Baltimore Street, Cumberland, Maryland 301-784-5412
Dr. Karin Savage.....	Director, Physical Therapist Assistant Program Allied Health Bldg. (A-233) 301-784-5535
Dr. Mark Shore.....	Chair, Mathematics and Engineering Humanities Bldg. (H-30) 301-784-5371
Mr. Jim House .....	Chair, Computer Science and Technology & Multimedia Technology Technology Bldg. (T-162) 301-784-5308
Dr. Rae Ann Smith .....	Director, Occupational Therapy Assistant Program Allied Health Bldg. (A-236) 301-784-5536
Ms. Cherie Snyder .....	Coordinator, Human Service Associate Allied Health Bldg. (AH-244) 301-784-5556
Ms. Cathy Wakefield .....	Director, Dental Hygiene Allied Health Bldg. (A-141) 301-784-5543

## **C. Pennsylvania Campuses Information - Services Offered Students**

Dr. Barbara Zuchelli  
Dean of Early College and PA Curriculum Development

### **Bedford County Campus**

Robin Swindell, Director of the Bedford County Campus and Student Services  
Denise Bouch, Site Coordinator and Student Council Advisor  
Mary Ann Clark, Coordinator of Student and Career Services  
Tina Imes, Office Assistant, Student Services/Foundation  
Derek Young, PA Campuses Coordinator of Financial Aid

### **Somerset County Campus**

Deb Hoover, Director of the Somerset County Campus and Student Services  
Leah Pepple, Coordinator of Community Foundation and Government Relations  
Brianna Livingston, Coordinator of Student and Career Services  
Tiffany Boone, Office Assistant, Early College and Curriculum Support  
Kecia Willison, Admission Specialist  
Darcy Gagnon, Administrative/Professional Support Staff  
Derek Young, PA Campuses Coordinator of Financial Aid

### **Career Advising**

Bedford County Campus: Student Services Office 814-652-9528, ext. 6204  
Somerset County Campus: Student Services Office 814-445-9848, ext. 6131

### **Transfer Information**

Bedford County Campus: Student Services Office 814-652-9528, ext. 6202  
Somerset County Campus: Student Services Office 814-445-9848, ext. 6106

### **Scholarships**

Bedford County Campus: Student Services Office 814-652-9528, ext. 6224  
Somerset County Campus: Student Services Office 814-445-9848, ext. 6131

### **Sources of Information in Your Community**

#### **Bedford County Campus**

18 North River Lane • Everett, PA 15537-1403  
814-652-9528 • FAX Number 814-652-9775

The Bedford County Campus is located on North River Lane adjacent to Everett Area High School. ACM's Technical Campus is located at the Bedford County Technical Center and houses the College's Nursing Program and lab science courses in addition to being the location for many technology courses. Office hours are Monday through Friday from 8:30 a.m. - 4:30 p.m. (Labor Day to Memorial Day) and 8:00 a.m. - 4:00 p.m. (Memorial Day to Labor Day). Evening hours are available as needed.

Services available at the Bedford County Campus include book sales, admissions/registration, advising, disability services, veteran affairs, and financial aid. The Bedford County Campus Library, located in the new addition, contains a book collection, a small magazine collection, and a small newspaper collection. At the center of the library are ten computers that give access to the library on-line catalog, the internet, Microsoft Office 2010 programs, and all of the online databases and electronic resources. There are over 2,200 books, periodicals, DVD and other media titles available within the Bedford County Campus library along with student access to the collections of material at the ACM Somerset and Cumberland libraries

Electronic resources available at the Pennsylvania Campuses include many different databases, electronic resources and eBooks. These databases contain hundreds of thousands of full-text articles and are a great research tool for students and faculty. Training on the databases and electronic resources is available from the librarians.

Library hours are posted on the College library website and library door.

**Somerset County Campus**

6022 Glades Pike, Suite 100 • Somerset, PA 15501-4300  
814-445-9848 • FAX Number 814-445-8132

The Somerset County Campus is located east of Somerset on Route 31. The Somerset County Library is located in Founders Hall on the campus. A new facility, Partners Hall, was recently added to the campus complex expanding facilities for health, science, technology, and agriculture. This facility also houses offices of Penn State Cooperative - Somerset, United States Department of Agriculture (USDA), and the Somerset County Conservation District.

Office hours are Monday through Friday from 8:00 a.m. - 4:00 p.m. (Memorial Day to Labor Day) and 8:30 a.m. - 4:30 p.m. (Labor Day to Memorial Day). Evening hours are available as needed.

Services available at the Somerset County Campus include admissions/registration, transfer and career advising, book sales, disability services, veteran affairs, placement assessment, tutoring, and resume writing. Through the Student Services Office, mini-transfer days are scheduled throughout the academic semester.

Electronic resources available at the Somerset County Campus include the college's online databases, electronic resources, eBooks, and access to the Pennsylvania Power Library. These databases contain hundreds of thousands of full-text articles and are a great research tool for students and faculty. Training on the databases, electronic resources, and Pennsylvania Power Library is available from the librarians.

Library services are provided by the Somerset County Public Library and Allegany College of Maryland; hours are posted on the College library website and on the Library door.

The phone number for the Somerset County Campus Library is 814-445-5907.

In addition, there are six computers available in the Somerset County Campus Library that provide easy access to the College's computerized library resources.

## II. College Calendar

### Fall Semester 2015

TERM	START DATE	END DATE
Full-Term (15 weeks)	August 24, 2015	December 11, 2015
Delayed Start (12 weeks)	September 21, 2015	December 11, 2015

August 21	Friday	Full-Term Last Day for Full Refund upon Withdrawal (Less Nonrefundable Fees)
<b>August 24</b>	<b>Monday</b>	<b>Full-Term Classes Begin</b>
August 28	Friday	Full-Term Last Day to Enroll in Classes (Instructor Approval Required)
<b>September 7</b>	<b>Monday</b>	<b>Labor Day; College Closed</b>
September 14	Monday	Full-Term Last Day for 80% Refund upon Withdrawal (Less Nonrefundable Fees)
September 18	Friday	Delayed Start Last Day for Full Refund upon Withdrawal (Less Nonrefundable Fees)
<b>September 21</b>	<b>Monday</b>	<b>Delayed Start Classes Begin</b>
October 2	Friday	Last Day to Apply for Fall Graduation
October 5	Monday	Delayed Start Classes last Day for 80% Refund upon Withdrawal (Less Nonrefundable Fees)
October 5	Monday	Last Day to Change "I" grades from Spring and Summer
October 12-16	Monday-Friday	Mid-Semester Evaluations
October 19	Monday	Full-Term Mid-Term Grades Due (10:00 a.m.)
<b>October 19 &amp; 20</b>	<b>Monday-Tuesday</b>	<b>Fall Break; No Classes</b>
October 21	Wednesday	Follow Monday Class Schedule
November 5	Thursday	Last Day to Drop Full-Term Classes
November 9	Monday	Advising and Registration Begins for Spring Semester 2016
November 16	Monday	Last Day to Drop Delayed Start Classes
<b>November 26 &amp; 27</b>	<b>Thursday-Friday</b>	<b>College Closed</b>
November 30	Monday	Classes Resume; First Day to Apply for Spring Graduation
<b>December 11</b>	<b>Friday</b>	<b>Full-Term and Delayed Start Classes End</b>
December 15	Tuesday	All Final Grades Due (2:00 p.m.)
December 18	Friday	Commencement Cumberland Campus (7:00 p.m.)
<b>December 19</b>	<b>Saturday</b>	<b>College Closed (December 19 – January 3)</b>

## Spring Semester 2016

TERM	START DATE	END DATE
Full-Term (15 weeks)	January 20, 2016	May 10, 2016
Delayed Start (12 weeks)	February 15, 2016	May 9, 2016

January 4	Monday	College Open – Late Registration Resumes for Spring Semester
January 19	Tuesday	Full-Term Last Day for Full Refund upon Withdrawal (Less Nonrefundable Fees)
<b>January 20</b>	<b>Wednesday</b>	<b>Full-Term Classes Begin</b>
January 26	Tuesday	Full-Term Last Day to Enroll in Classes (Instructor Approval Required)
February 9	Tuesday	Full-Term Last Day for 80% Refund upon Withdrawal (Less Nonrefundable Fees)
February 12	Friday	Last Day to Apply for Spring Graduation
February 12	Friday	Delayed Start Classes Last Day for Full Refund upon Withdrawal (Less Nonrefundable Fees)
<b>February 15</b>	<b>Monday</b>	<b>Delayed Start Classes Begin</b>
February 16	Tuesday	Last Day to Change “I” grades from Fall
February 22	Monday	Delayed Start Classes Last Day to Enroll in Classes (Instructor Approval Required)
February 29	Monday	Delayed Start Classes Last Day for 80% Refund upon Withdrawal (Less Nonrefundable Fees)
February 29-March 4	Monday-Friday	Mid-Semester Evaluations
March 7	Monday	Full-Term Mid-Term Grades Due (10:00 a.m.)
March 22	Tuesday	Last Day to Drop Full-Term Classes
<b>March 21-25</b>	<b>Monday-Friday</b>	<b>Spring Break; No Classes</b>
<b>March 24 &amp; 25</b>	<b>Thursday-Friday</b>	<b>College Closed</b>
April 4	Monday	Advising and Early Registration Begins for Summer and Fall 2016 Semesters
April 18	Monday	Last Day to Drop Delayed Start Classes
<b>May 9</b>	<b>Monday</b>	<b>Delayed Start Classes End</b>
<b>May 10</b>	<b>Tuesday</b>	<b>Full-Term Classes End</b>
May 15	Sunday	All Final Course Grades Due (11:59 p.m.)
May 21	Saturday	Commencement Cumberland Campus (11:00 a.m. & 2:00 p.m.)
May 23	Monday	Commencement Bedford County Campus (7:00 p.m.)
May 24	Tuesday	Commencement Somerset County Campus (7:00 p.m.)

**Summer Session 2016**

<b>TERM</b>	<b>START DATE</b>	<b>END DATE</b>
Full-Term (10 weeks)	May 31, 2016	August 5, 2016
A-Term (5 weeks)	May 31, 2016	July 1, 2016
B-Term (5 weeks)	July 5, 2016	August 5, 2016

May 27	Friday	Full-Term and A-Term Last Day for Full Refund upon Withdrawal (Less Nonrefundable Fees)
<b>May 30</b>	<b>Monday</b>	<b>Memorial Day; College Closed</b>
<b>May 31</b>	<b>Tuesday</b>	<b>Full-Term and A-Term Classes Begin</b>
June 1	Wednesday	A-Term Last Day to Enroll in Classes (Instructor Approval Required)
June 2	Thursday	Full-Term Last Day to Enroll in Classes (Instructor Approval Required)
June 6	Monday	A-Term Last Day for 80% Refund upon Withdrawal (Less Nonrefundable Fees)
June 10	Friday	Last Day to Apply for Summer Graduation
June 13	Monday	Full-Term Last Day for 80% Refund upon Withdrawal (Less Nonrefundable fees)
June 15	Monday	A-Term Last Day to Drop Classes
<b>July 1</b>	<b>Friday</b>	<b>A-Term Classes End</b>
July 1	Friday	B-Term Last Day for Full Refund upon Withdrawal (Less Nonrefundable Fees)
<b>July 4</b>	<b>Monday</b>	<b>Independence Day Holiday; College Closed</b>
<b>July 5</b>	<b>Tuesday</b>	<b>B-Term Classes Begin</b>
July 5	Tuesday	A-Term Final Grades Due (10:00 a.m.)
July 6	Wednesday	B-Term Last Day to Enroll in Classes (Instructor Approval Required)
July 11	Monday	Full-Term Last Day to Drop Classes
July 11	Monday	B-Term Last Day for 80% Refund upon Withdrawal (Less Nonrefundable Fees)
July 18	Monday	B-Term Last Day to Drop Classes
<b>August 5</b>	<b>Friday</b>	<b>Full-Term and B-Term Classes End</b>
August 8	Monday	All Final Grades Due (10:00 a.m.)
August 8	Monday	Late Registration Begins for Fall Semester 2016
August 12	Friday	Summer Graduation







*College Center - Loft*

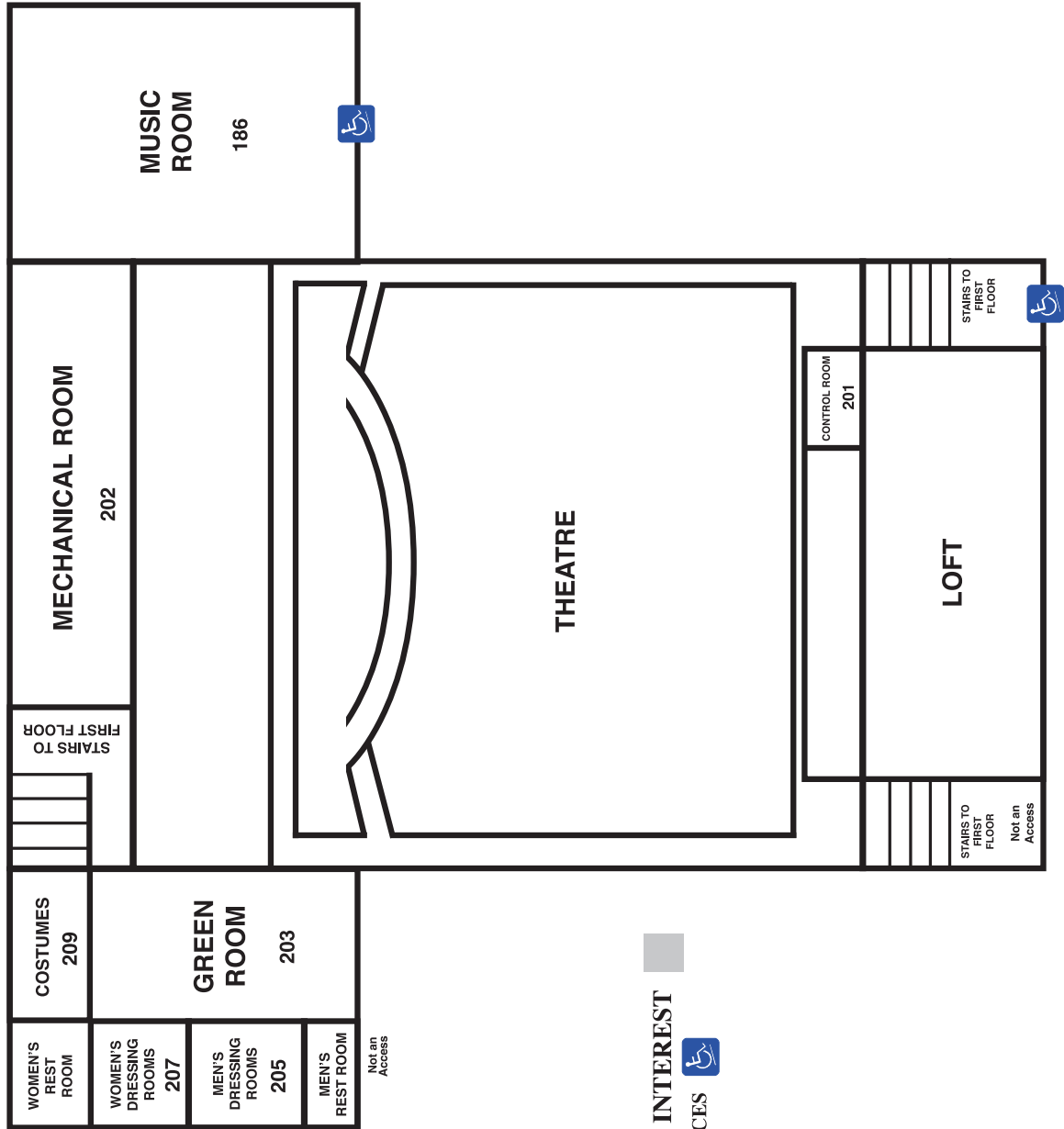

*Advancement/Campus Bookstore*

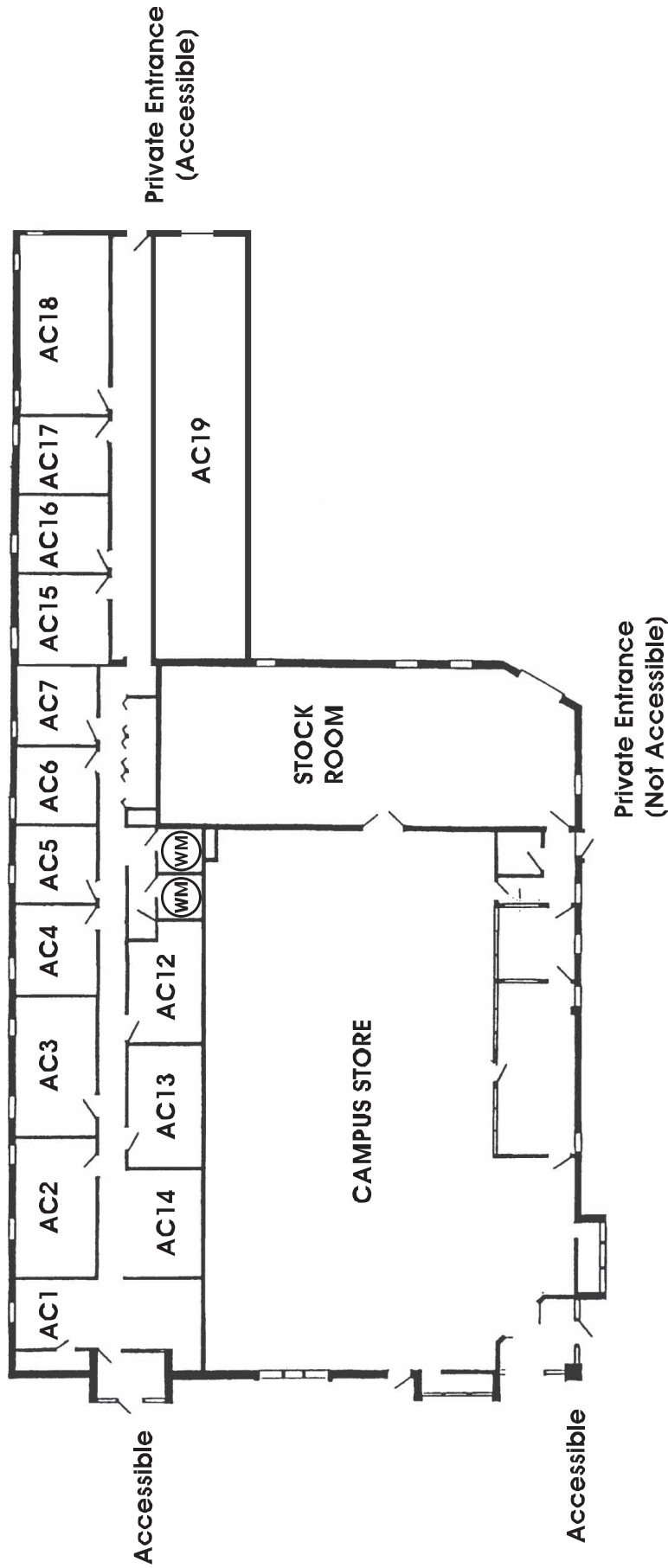

All Public Entrances are accessible.

*Allied Health - 1st Floor*

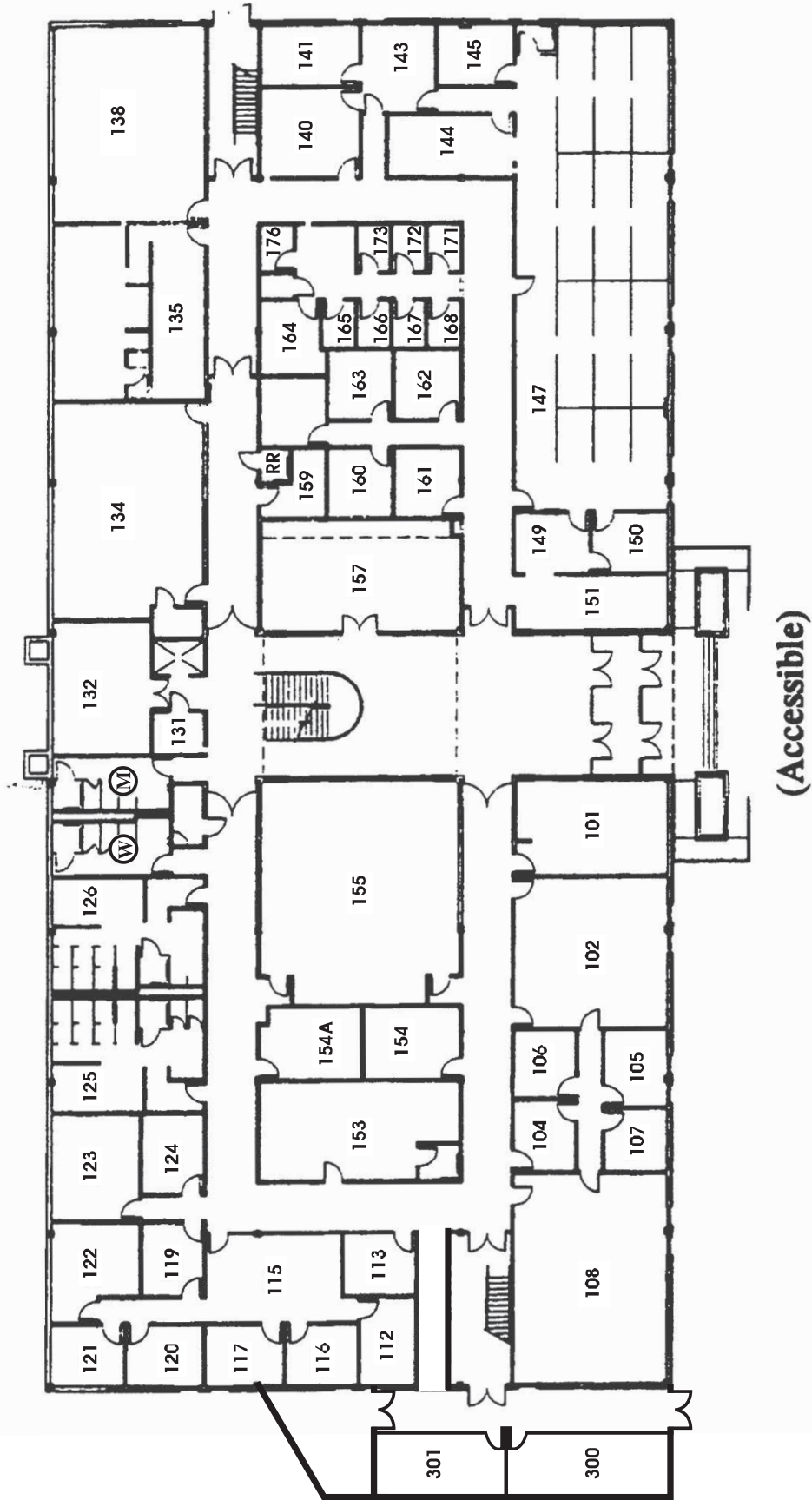

The main entrances are accessible.

This building has been renovated;  
the floor plan may not be exact.

*Allied Health - 2nd Floor*

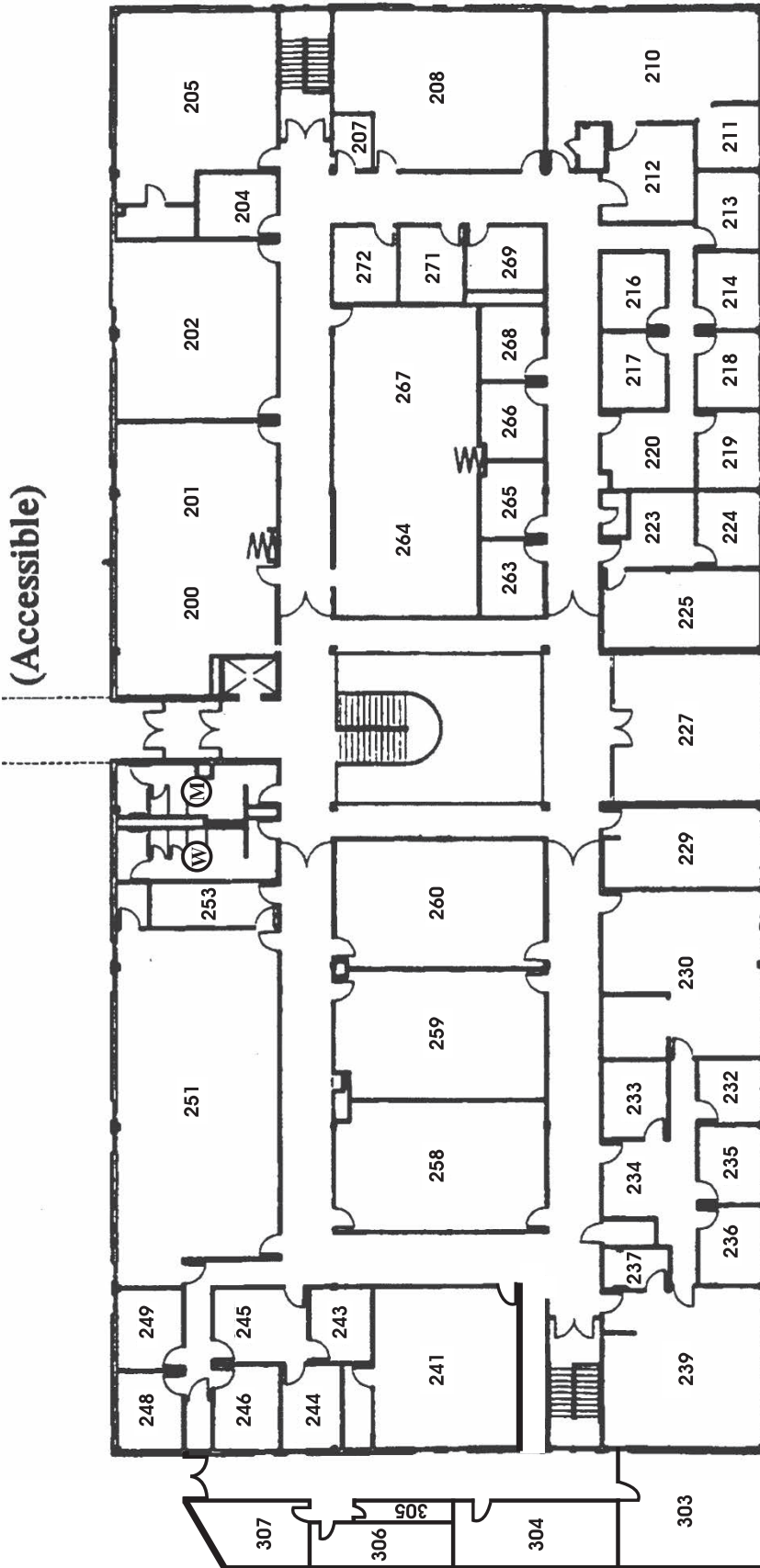

The main entrances are accessible.

This building has been renovated;  
the floor plan may not be exact.

**Automotive Technology**

**Automotive Technology Maintenance**

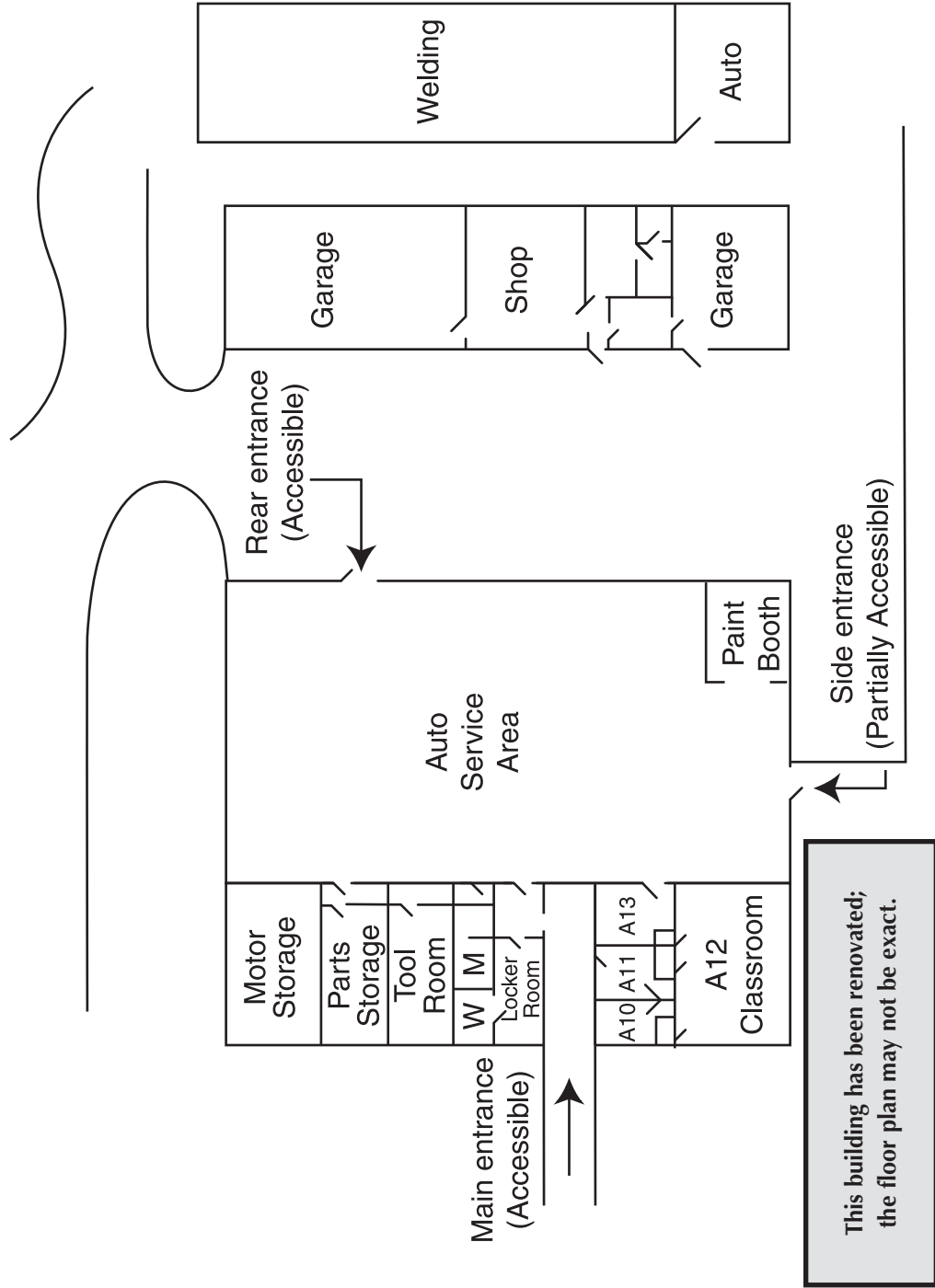

- The main entrance is accessible.
- Building in one story; hence, all classrooms, offices and facilities are readily accessible once inside.

*Continuing Education*

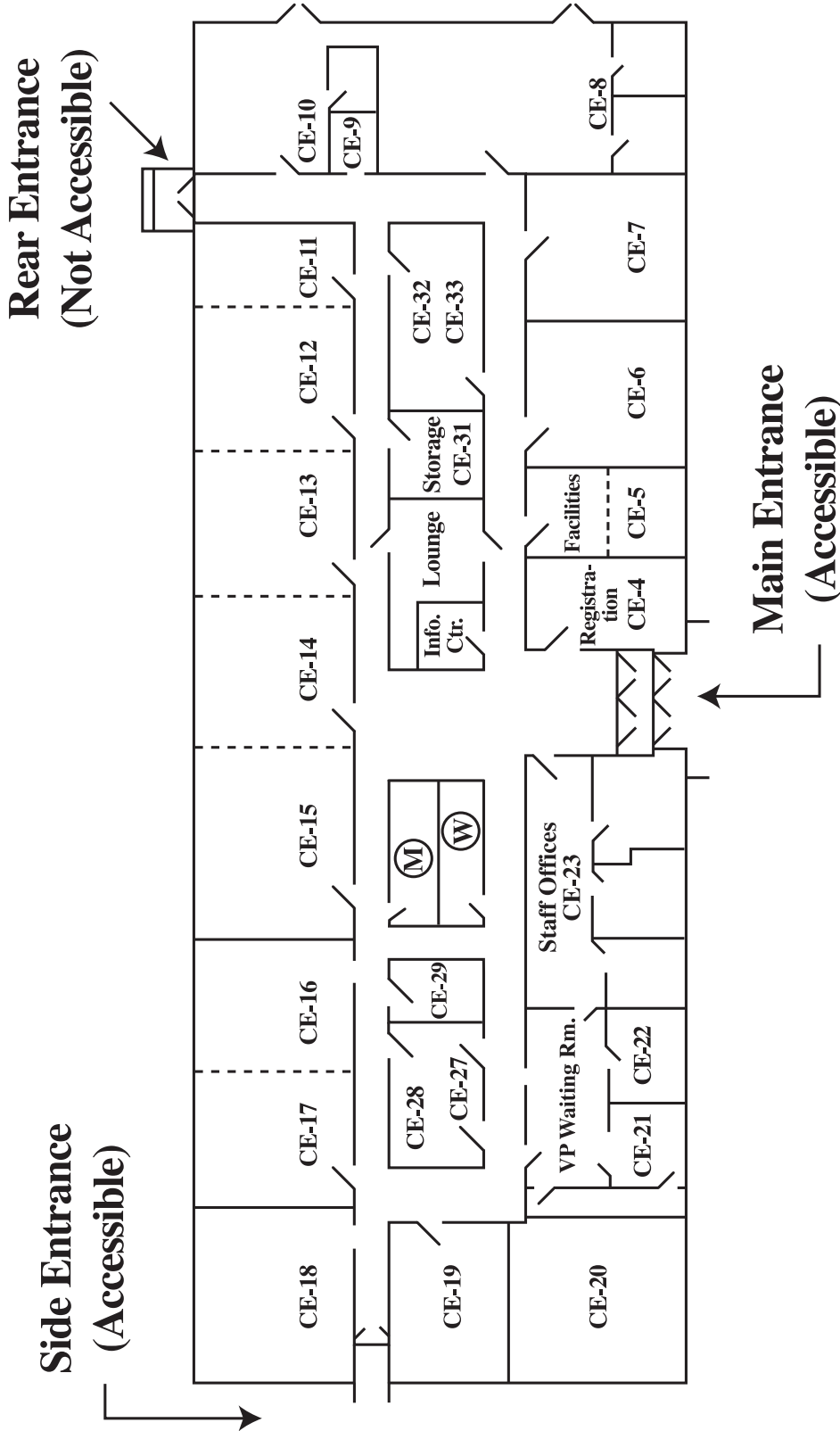

- The Main Entrance is accessible.
- Building is one story; hence, all classrooms, offices, and facilities are readily accessible once inside.
- Restrooms are equipped for the handicapped.
- Wheelchairs available. Please contact the Information Office.

**Humanities**

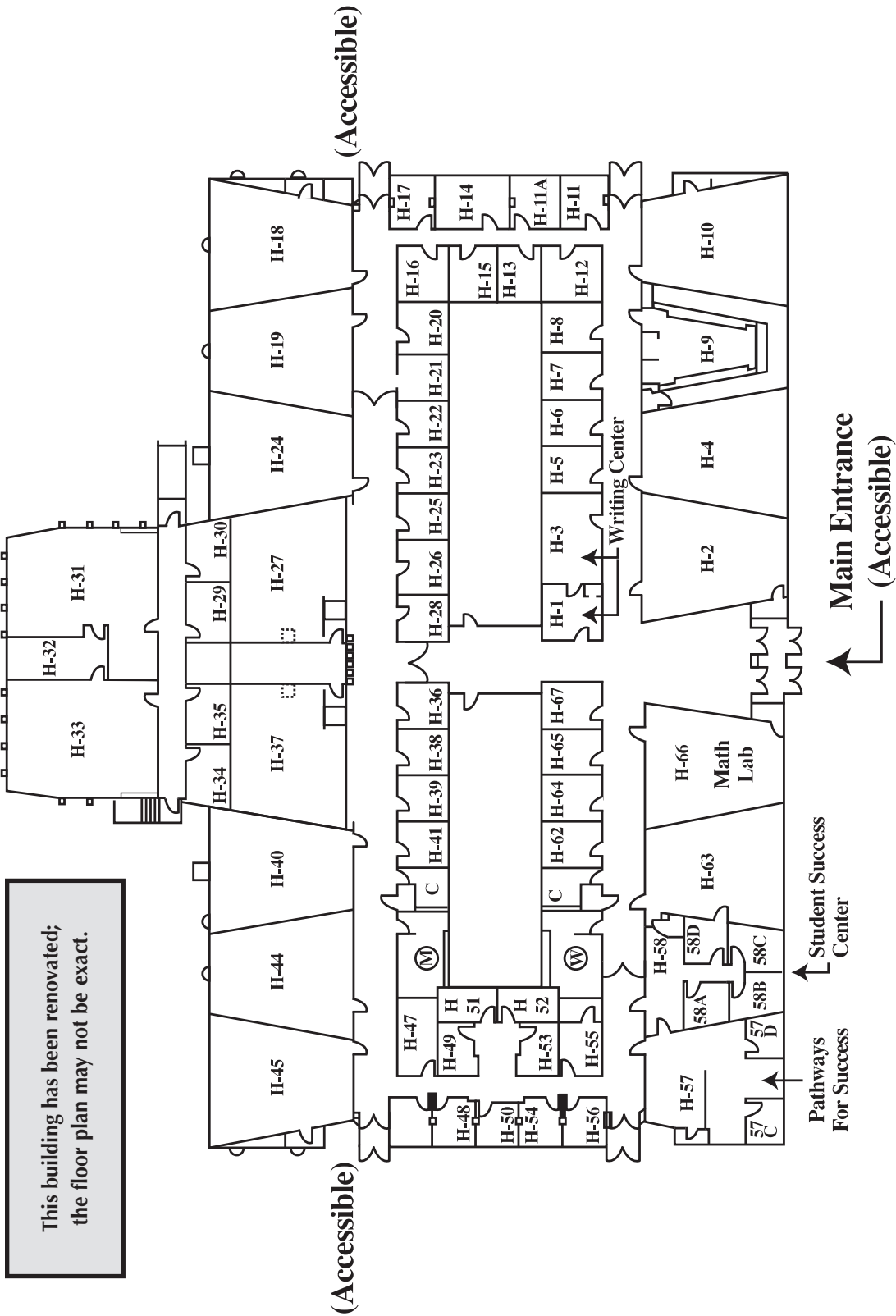

This building has been renovated; the floor plan may not be exact.

- The main entrance (by the reflecting pools; opposite the Library) is accessible.
- Building is one story; hence, all classrooms and offices are readily accessible once inside.
- The side entrances are accessible.



*Donald L. Alexander Library*

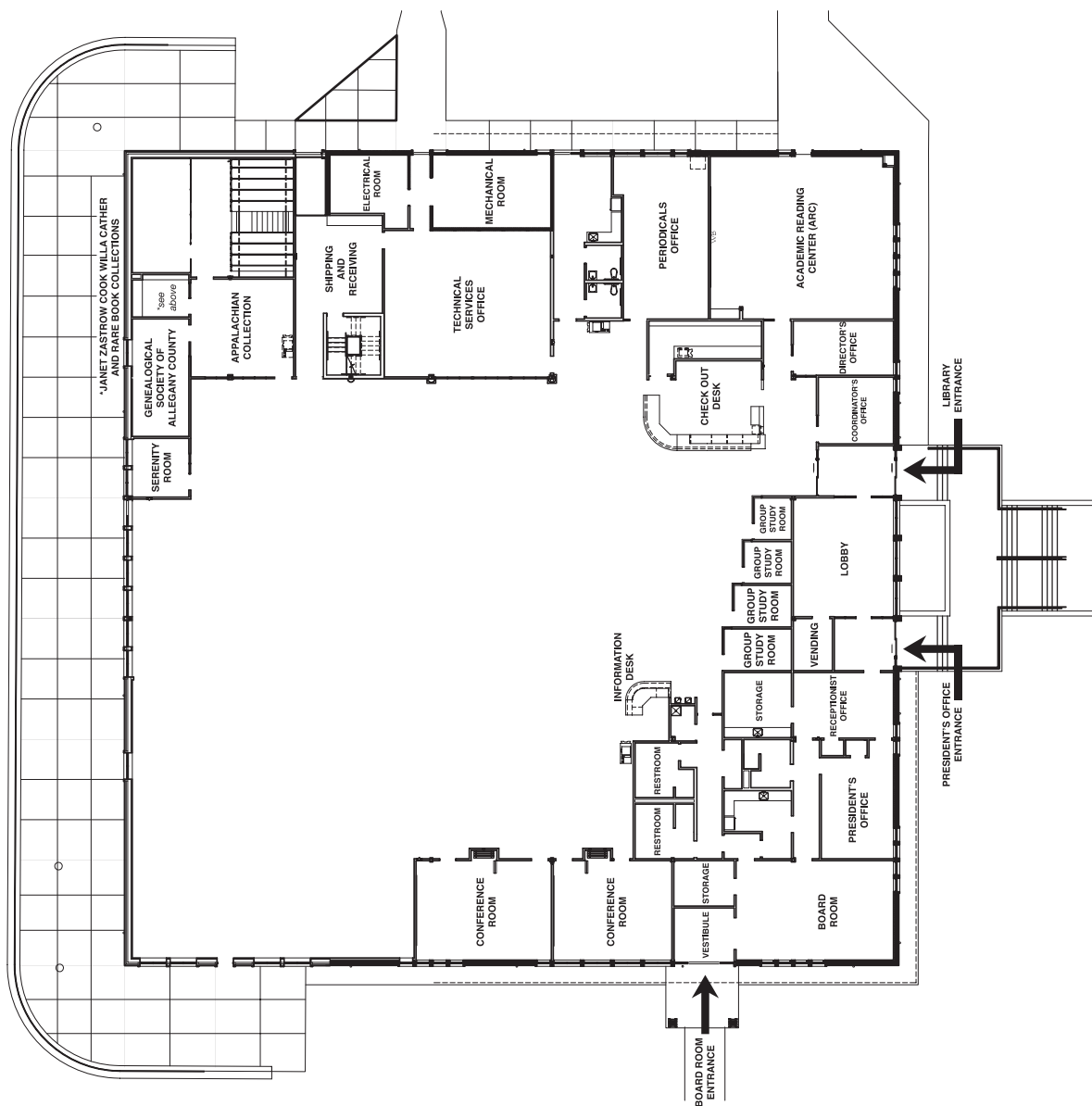

*Physical Education*

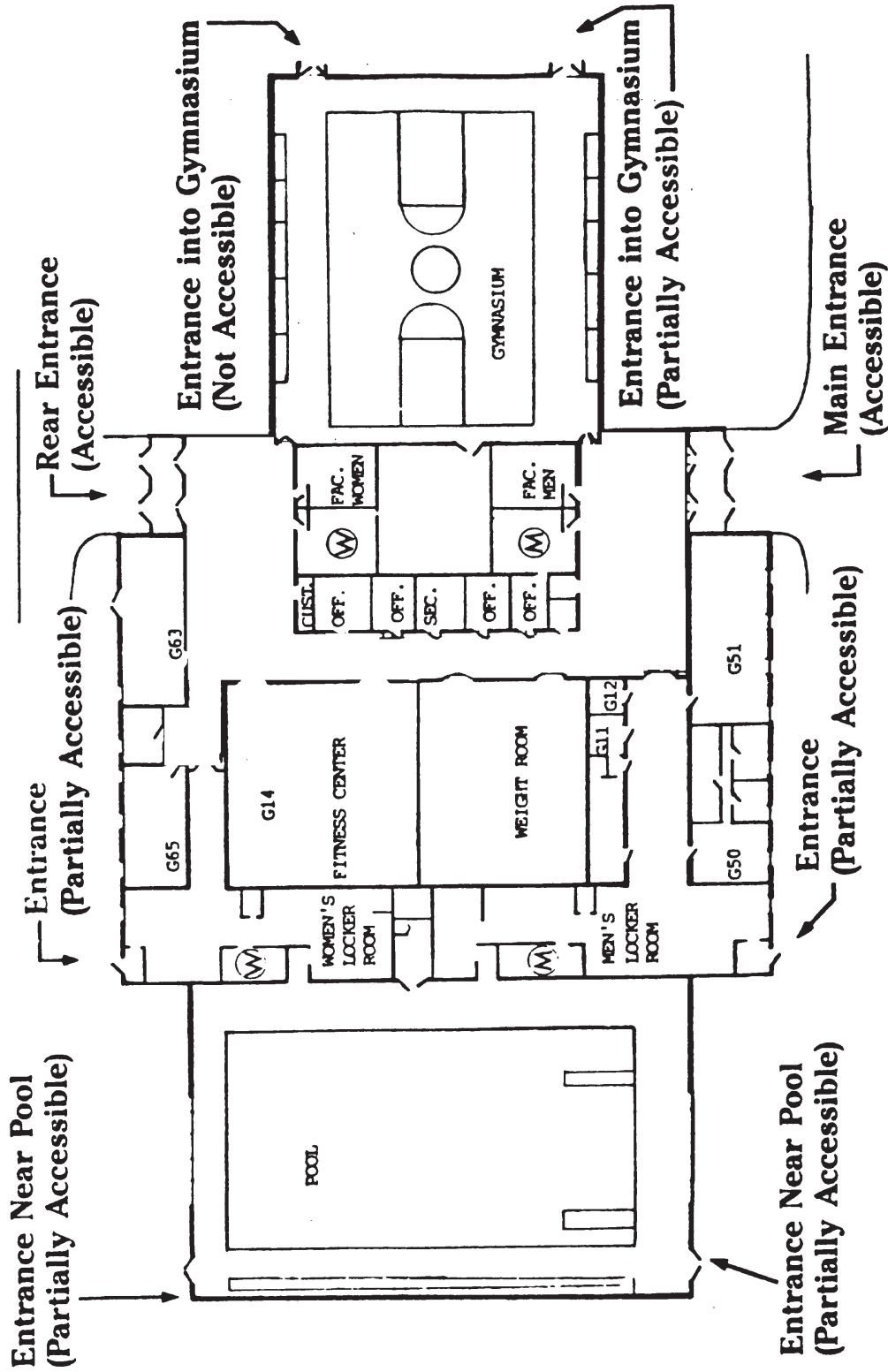

This building has been renovated; the floor plan may not be exact.

Sciences

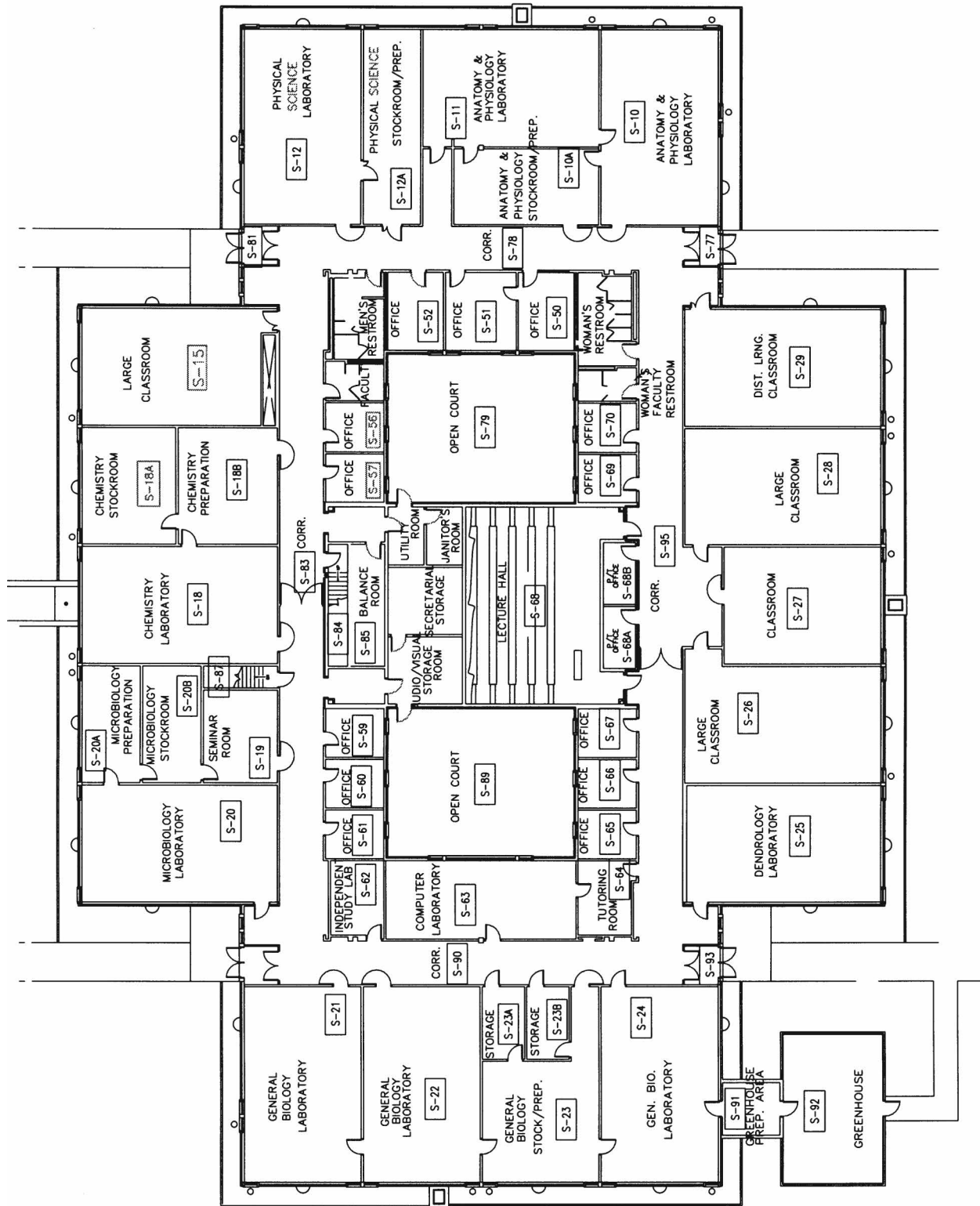

*Technologies - 1st Floor*

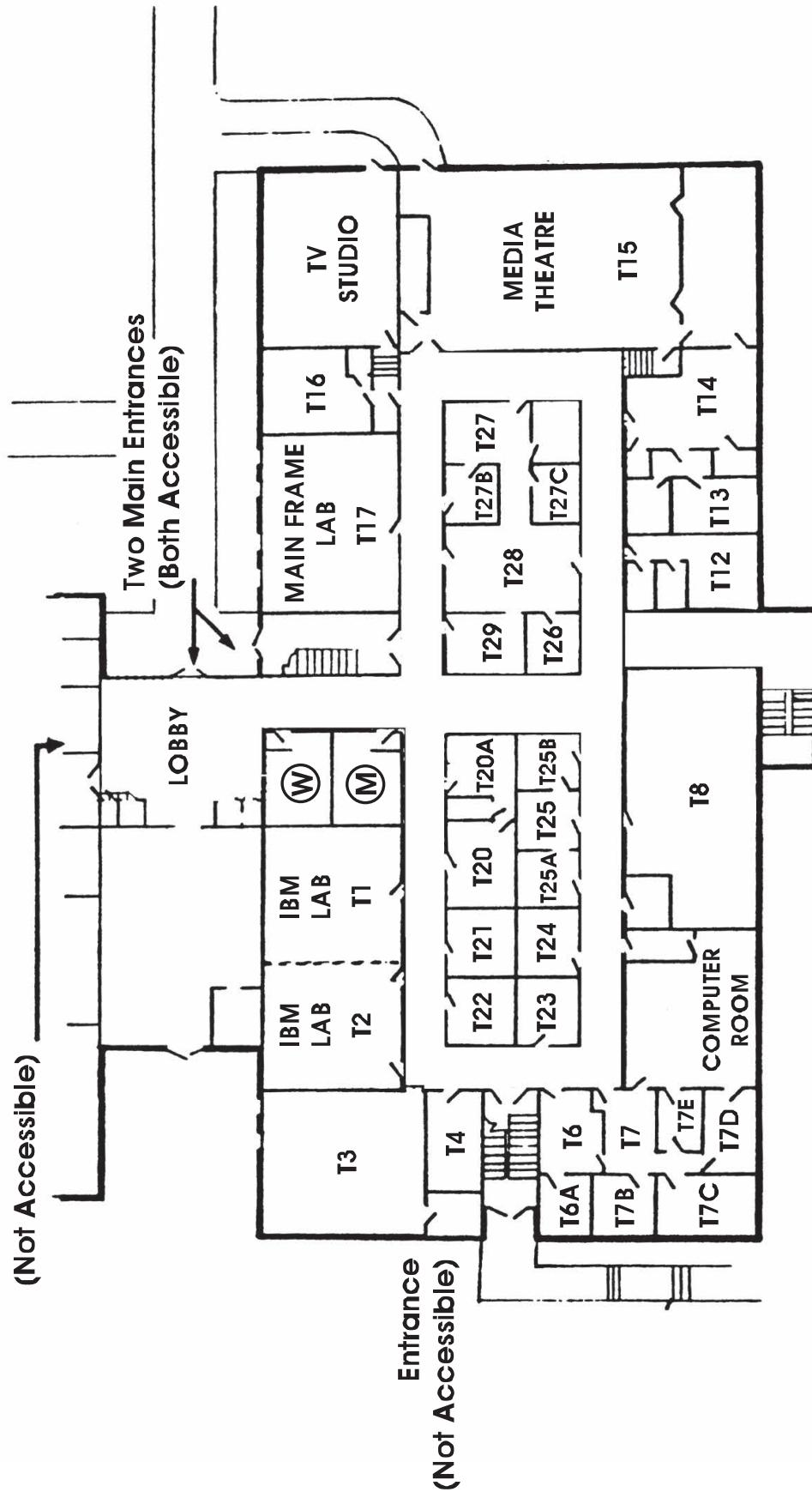

- The Technology Building is three stories. Access from floor to floor is not possible, except by outside entrances.
- The main entrances are accessible.

*Technologies - 2nd Floor*

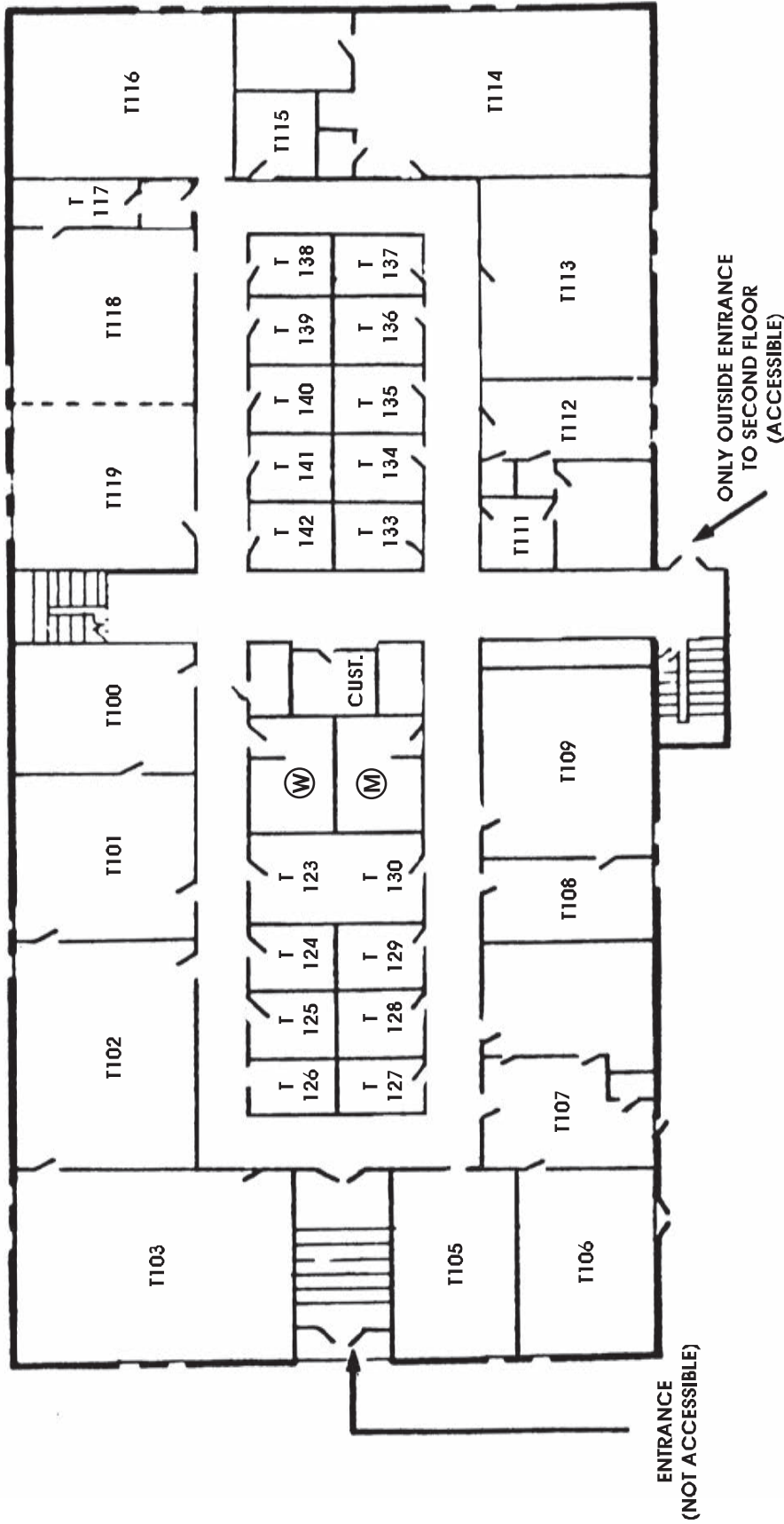

- The second floor is accessible from the parking lot entrance.
- Restrooms are equipped for the handicapped.

*Technologies - 1st Floor Lobby & 2nd Floor Extension*

SECOND FLOOR EXTENSION

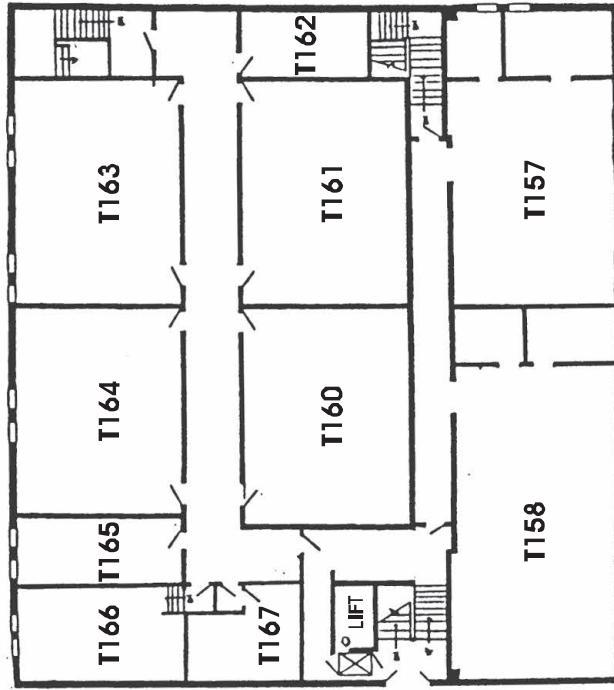

- The second floor is accessible by lift located adjacent to main entrance lobby.

FIRST FLOOR LOBBY

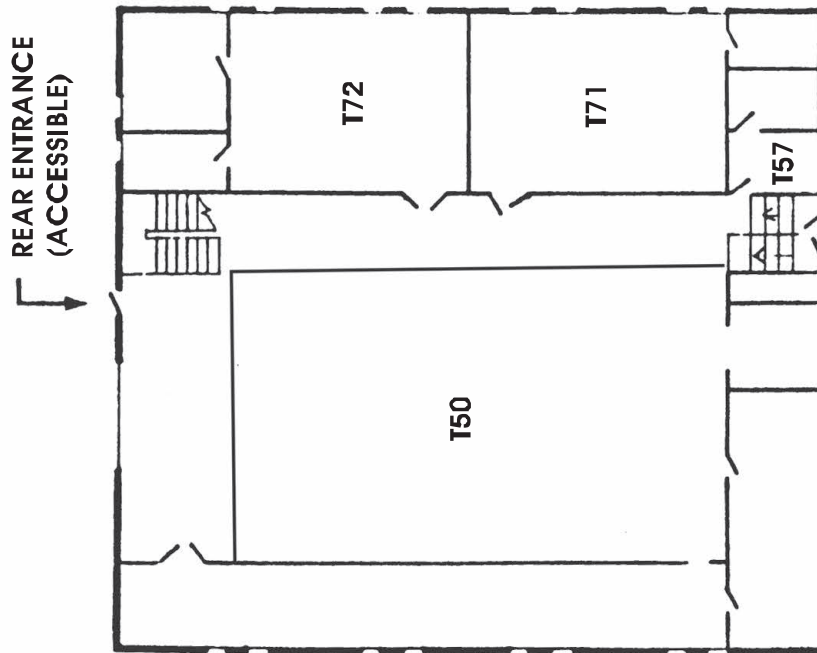

ENTRANCE  
from First Floor Lobby  
(NOT ACCESSIBLE)

*Bedford County Campus*

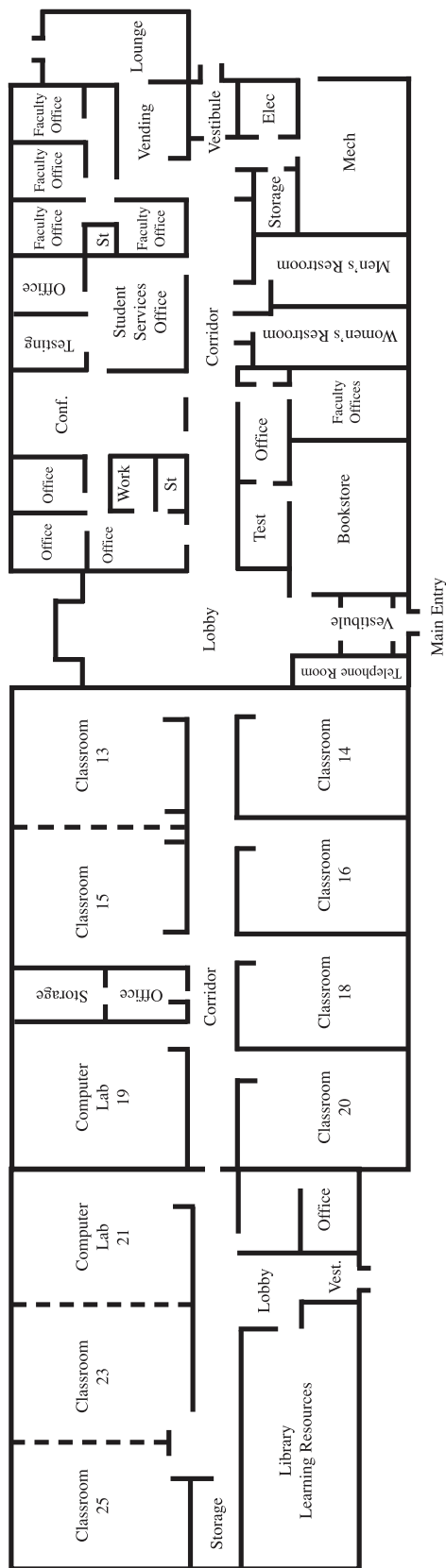





*Somerset County Campus - Partners Hall*

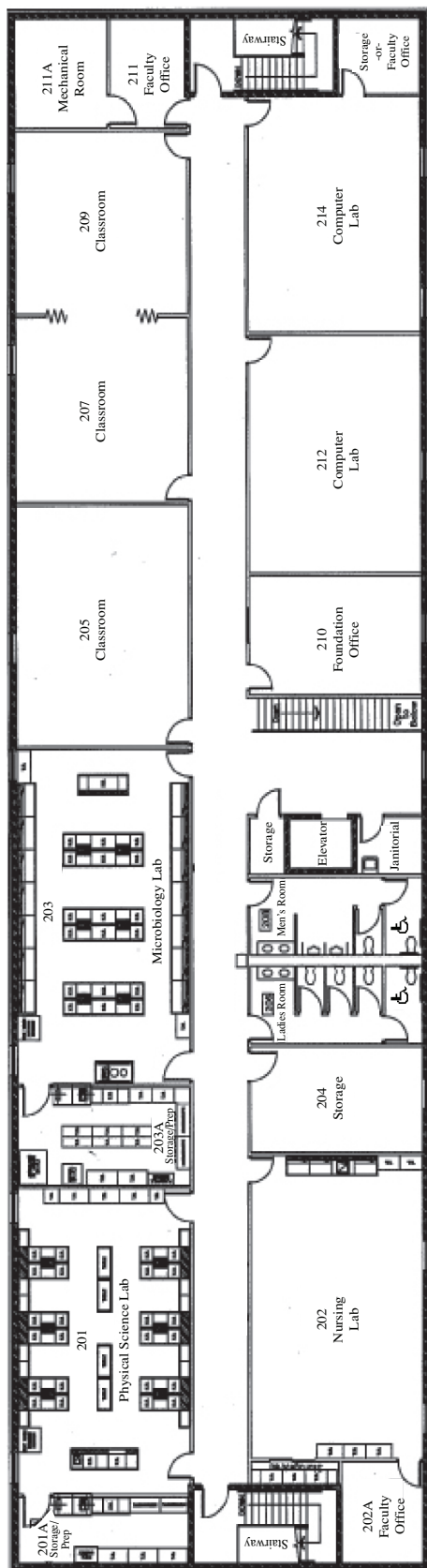



# IV. Campus Map

## Cumberland Campus Map

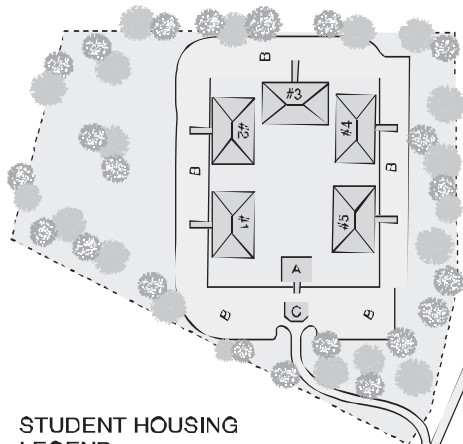

◀ Willowbrook Woods Student Housing Complex

### STUDENT HOUSING LEGEND

- 1 • STUDENT HOUSING BUILDING
- 2 • STUDENT HOUSING BUILDING
- 3 • STUDENT HOUSING BUILDING
- 4 • STUDENT HOUSING BUILDING
- 5 • STUDENT HOUSING BUILDING
- A • CLUB HOUSE
- B • PARKING
- C • GATEHOUSE

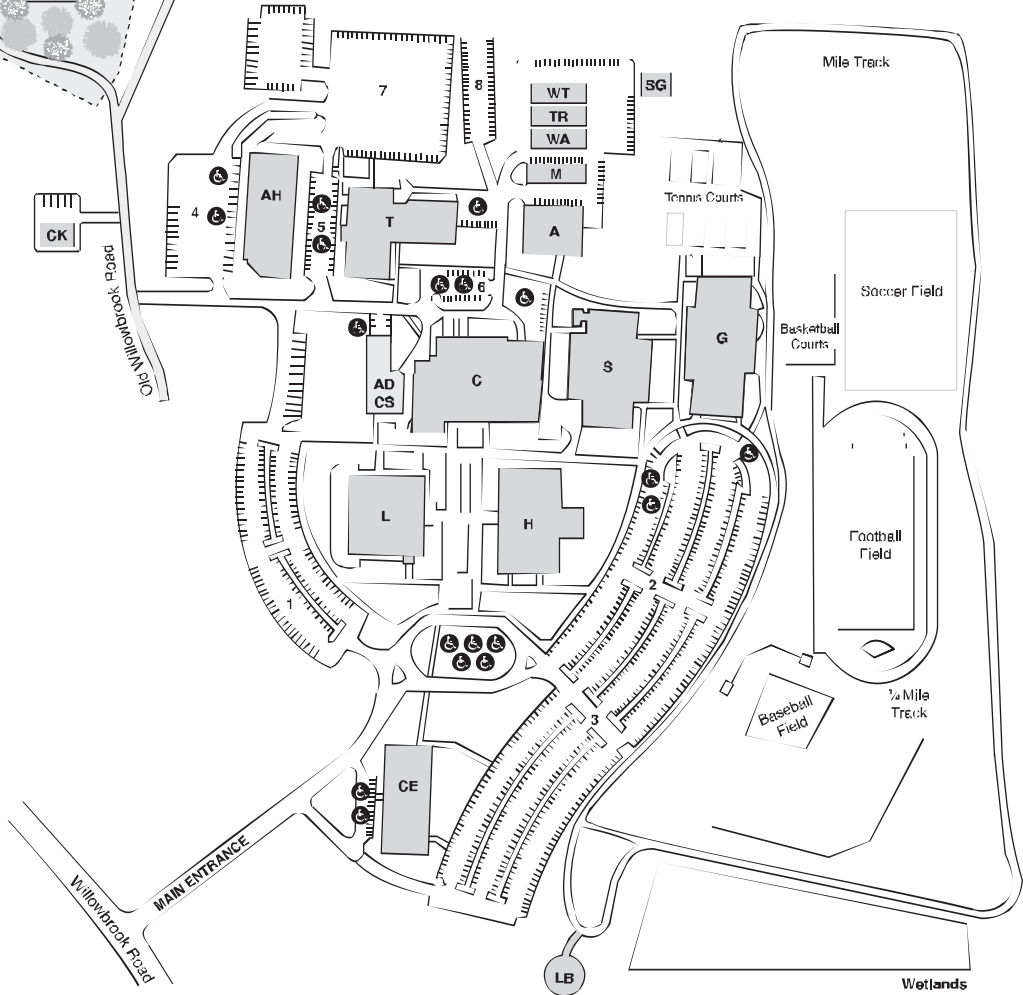

• THIS MAP NOT TO SCALE

### LEGEND

<b>A</b> Automotive Technology	<b>CS</b> Campus Store	<b>SG</b> Storage
<b>AD</b> Advancement (Foundation, Public Relations, Marketing)	<b>G</b> Gymnasium (Bnb Kirk Arena)	<b>T</b> Tooling/Inotics
<b>AH</b> Allied Health	<b>H</b> Humanities	<b>TR</b> Transportation
<b>C</b> College Center	<b>L</b> Donald L. Alexander Library	<b>WA</b> Welding & Auto
<b>CE</b> Continuing Education (Information Center)	<b>LB</b> Labyrinth	<b>WT</b> Workforce Training
<b>CK</b> Campus Kids Child Care Center	<b>M</b> Maintenance	<b>1-8</b> Parking
	<b>S</b> Sciences	<b>♿</b> Handicap Parking

Financial Aid, Admissions/Registration, Advising Center, Business and Student Housing Offices are located in the College Center (C). Ample parking is available, with reserved parking identified for the handicapped.

1/15